

TECHNICAL DATA INCLUDED IN THIS BROCHURE MAY BE CHANGE FROM TIME TO TIME DUE TO THE PRODUCT IMPROVEMENTS UNDERTAKES BY THE MANUFACTURER. THE COMPANY RESERVES THE UNCONDITIONAL RIGHTS TO IMPLEMENT SUCH CHANGES WITHOUT REFERENCE TO THIRD PARTIES.

**APK** 郑州神龙泵业有限公司  
ZHENGZHOU SHENLONG PUMP INDUSTRY CO.,LTD

Add: E-commerce industrial park, Industrial development zone, Zhengzhou, He'nan province, China

E-mail: [info@apkpump.com](mailto:info@apkpump.com)

Tel: 0086-0371-56066186

Wed: [www.dragonpump.com](http://www.dragonpump.com)

**APK** 神龙泵业



**50HZ Vertical Multistage Pump**

**郑州神龙泵业有限公司**

ZHENGZHOU SHENLONG PUMP INDUSTRY CO.,LTD



Performance scope.....1  
 General data.....2  
 Pressure.....3  
 NPSH.....4  
 Curve description.....5  
 Exploded view.....06-09  
 CDL,CDLF1.....10-11  
 CDL,CDLF2.....12-13  
 CDL,CDLF3.....14-15  
 CDL,CDLF4.....16-17  
 CDL,CDLF5.....18-19  
 CDL,CDLF8.....20-21  
 CDL,CDLF12.....22-23  
 CDL,CDLF16.....24-25  
 CDL,CDLF20.....26-27  
 CDL,CDLF32.....28-29  
 CDL,CDLF42.....30-31  
 CDL,CDLF65.....32-33  
 CDL,CDLF85.....34-35  
 CDL,CDLF120.....36-37  
 CDL,CDLF150.....38-39



Performance scope

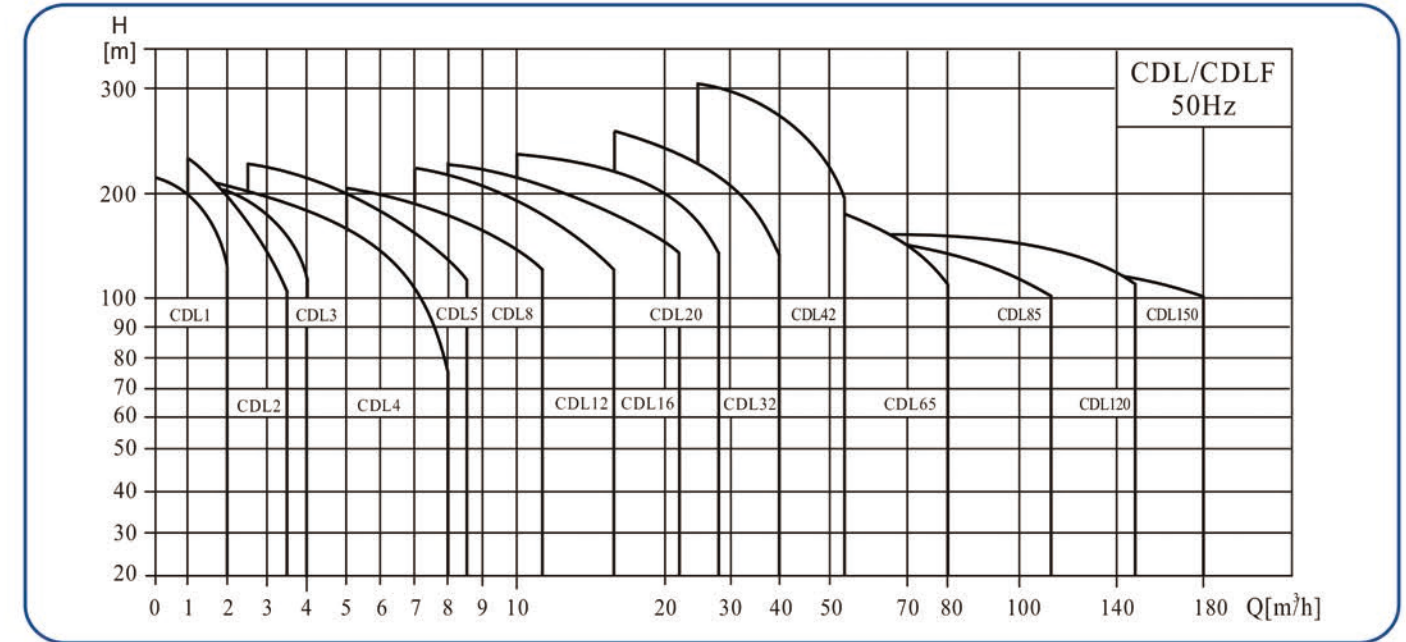

Product range

Description	CDL1	CDL2	CDL3	CDL4	CDL5	CDL8	CDL12	CDL16	CDL20	CDL32	CDL42	CDL65	CDL85	CDL120	CDL150
Rated flow [m³/h]	1	2	3	4	5	8	12	16	20	32	42	65	85	120	150
Rated flow [l/s]	0.28	0.56	0.83	1.1	1.39	2.2	3.3	4.4	5.6	8.9	11.7	18	24	33	41.6
Flow range [m³/h]	0.4-2	1-3.5	1.2-4	1.5-7	2.5-8.5	5-12	7-16	8-22	10-28	16-40	25-55	30-80	50-110	60-150	80-180
Flow range [l/s]	0.11-0.56	0.28-0.97	0.33-1.1	0.42-1.9	0.69-2.36	1.4-3.3	1.9-4.4	2.2-6.1	2.8-7.8	4.4-11.1	6.9-15.3	8.3-22.2	13.8-30.5	16.7-41.7	22-50
Max.pressure [bar]	21	23	22	21	24	21	22	22	23	26	30	22	17	16	16
Motor power [kw]	0.37-2.2	0.37-3	0.37-3	0.37-4	0.37-5.5	0.75-7.5	1.5-11	2.2-15	1.1-18.5	1.5-30	3-45	4-45	5.5-45	11-75	11-75
Temperature range [C]	Normal Temperature, Hight Temperature														
Max. efficiency [%]	44	46	54	59	66	64	63	66	69	76	78	80	81	74	73
Type															
CDL	●	●	●	●	●	●	●	●	●	●	●	●	●	●	●
CDLF	●	●	●	●	●	●	●	●	●	●	●	●	●	●	●
CDL pipe connection															
DIN Flange	DN25	DN25	DN25	DN32	DN32	DN40	DN50	DN50	DN50	DN65	DN80	DN100	DN100	DN125	DN125
Oval Flange	G1	G1	G1	G1 1/4	G1 1/4	G1 1/2									
CDLF pipe connection															
DIN Flange	DN25	DN25	DN25	DN32	DN32	DN40	DN50	DN50	DN50	DN65	DN80	DN100	DN100	DN125	DN125
Cutting ferrule joint	●	●	●	●	●	●	●	●	●						
Pipe thread	●	●	●	●	●	●	●	●	●						



**Application**

CDL/CDLF pump are multi-functional products. It can be used to convey various medium from tap water to industrial liquid at different temperature and with different flow rate and pressure. CDL type is applicable to conveying non-corrosive liquid, while CDLF is suitable for slightly corrosive liquid.

- Water supply: water filter and transport in waterworks, boosting of main pipeline, boosting in high rise building.
- Industrial boosting: process flow water system, cleaning system, high pressure washing system, fire fighting system.
- Industrial liquid conveying: Cooling and air-conditioning system, boiler water supply and condensing system, machine-associated purpose, acids and alkali.
- Water treatment: ultrafiltration system, RO system, distillation system, separator, swimming pool.
- Irrigation: Farmland irrigation, dripping irrigation.

**Pump**

CDL/CDLF pump are vertical non-self priming multistage centrifugal pump, which is driven by a standard electric motor. The motor output shaft directly connects with the pump shaft through a coupling. The pressure resistant cylinder and flow passage components are fixed between pump head and in-and outlet section with tie-bar bolts. The inlet and outlet are located at the pump bottom at the same plane. This kind of pump can be equipped with an intelligent protector to effectively prevent it from dry-running, out-of-phase and overload.

**Operation conditions**

- Thin, clean, non-flammable and non-explosive liquid containing no solid granules and fibers.
- Liquid temperature:  
Normal temperature, High temperature
- Ambient temperature: up to +40°C
- Altitude: up to 1000m

**Pump motor**

- Total enclosed fan-cooled two-pole standard motor
- Protection class: IP55
- Insulation class: F
- Standard voltage: 50Hz: 1x220-230/240V 3x200-200/346-380V 3x220-240/380-415V 3x380-415V

**Pump model**

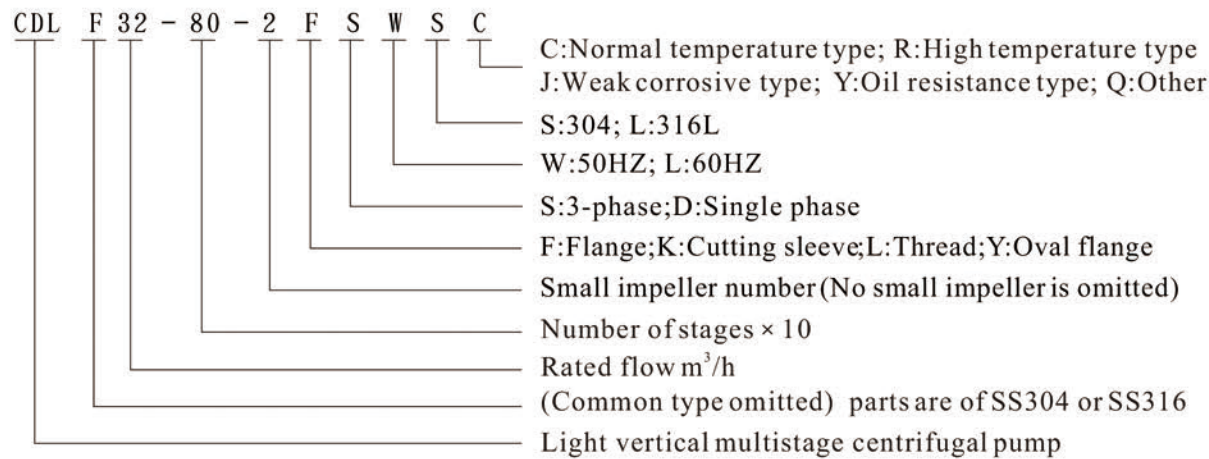

**Max inlet pressure**

The max. inlet pressure is shown in the table below. But the actual inlet pressure plus the valve close pressure of the pump shall be lower than the max. allowable working pressure.

CDL, CDLF1	Max inlet pressure[Bar]
1-2 ~ 1-8	6
1-9 ~ 1-36	10
CDL, CDLF2	
2-2	6
2-3 ~ 2-11	10
2-13 ~ 2-26	15
CDL, CDLF3	
3-2 ~ 3-5	6
3-6 ~ 3-29	10
3-31 ~ 3-36	15
CDL, CDLF4	
4-2	6
4-3 ~ 2-10	10
4-12 ~ 4-22	15
CDL, CDLF5	
5-2 ~ 5-16	10
5-18 ~ 5-36	15
CDL, CDLF8	
8-2 ~ 8-6	6
8-8 ~ 8-20	10
CDL, CDLF12	
12-2 ~ 12-4	6
12-5 ~ 12-18	10
CDL, CDLF16	
16-2 ~ 16-3	6
16-4 ~ 16-16	10
CDL, CDLF20	
20-1 ~ 20-3	6
20-4 ~ 20-17	10
CDL, CDLF32	
32-10-1 ~ 32-20-2	3
32-20 ~ 32-40	4
32-50-2 ~ 32-100	10
32-110-2 ~ 32-140	15
CDL, CDLF42	
42-10-1	3
42-10 ~ 42-20	4
42-30-2 ~ 42-50	10
42-60-2 ~ 42-130-2	15
CDL, CDLF65	
65-10-1 ~ 65-20-2	4
65-20-1 ~ 65-30	10
65-40-2 ~ 65-80-1	15
CDL, CDLF85	
85-10-1 ~ 85-10	4
85-20-2 ~ 85-30-2	10
85-30-1 ~ 85-60	15
CDL, CDLF120, 150	15

**Max working pressure**

CDL, CDLF1	Curve number
1-2 ~ 1-23	1
1-25 ~ 1-36	2
CDL, CDLF2	
2-2 ~ 2-15	1
2-18 ~ 2-26	2
CDL, CDLF3	
3-2 ~ 3-23	1
3-25 ~ 3-36	2
CDL, CDLF4	
4-2 ~ 4-16	1
4-19 ~ 4-22	2
CDL, CDLF5	
5-2 ~ 5-23	1
5-25 ~ 5-36	2
CDL, CDLF8	
8-2 ~ 8-12	1
8-14 ~ 8-20	3
CDL, CDLF12	
12-2 ~ 12-10	1
12-12 ~ 12-18	3
CDL, CDLF16	
16-2 ~ 16-8	1
16-10 ~ 16-16	3
CDL, CDLF20	
20-1 ~ 20-8	1
20-10 ~ 20-17	3
CDL, CDLF32	
32-10-1 ~ 32-70	1
32-80-2 ~ 32-120	4
32-130 ~ 32-140	5
CDL, CDLF42	
42-10-1 ~ 42-60	1
42-70-2 ~ 42-90	4
42-100-2 ~ 42-130-2	5
CDL, CDLF65	
65-10-1 ~ 65-50	1
65-60-2 ~ 65-80-1	4
CDL, CDLF85	
85-10-1 ~ 85-50-2	1
85-50 ~ 85-60	4
CDL, CDLF120, 150	6

The following figure shows the limitation of pressure and temperature which shall be kept within the region as show in the figure

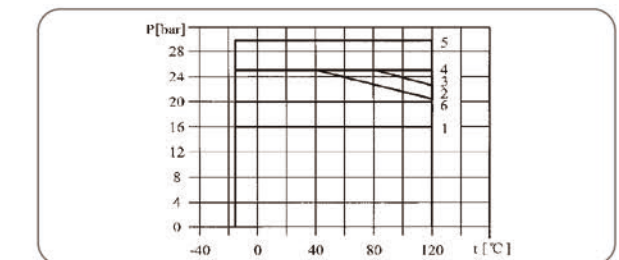



**Minimum inlet pressure NPSH**

In case that the pressure in pump is lower than the steam pressure used to convey liquid, the cavitations will occur. To avoid cavitations, a minimum pressure at the inlet side of the pump shall be guaranteed. The max. Suction lift H in metres head can be calculated as following formula:

$$H = P_b \times 10.2 - NPSH - H_f - H_v - H_s$$

$P_b$  = Barometric pressure in bar.

(Barometric pressure can be set to 1 bar.)

In closed system,  $P_b$  indicates the system pressure in bar.

NPSH = Net positive suction head in metres head.

(It can be read out from the point of possible max flow rate shown on NPSH curve)

$H_f$  = Friction loss in suction pipe in metres head at the highest flow the pump will be delivering.

$H_v$  = Vapour pressure in metres head, see fig

$H_s$  = Safety margin = Minimum 0.5 metres head

If the calculated result H is positive, the pump can operate at a suction lift of max. H metres head.

If the calculated result H is negative, an inlet pressure of minimum H metres head is required. There must be a pressure equal to the calculated H during operation.

Check and ensure that the pump is not in cavitations state

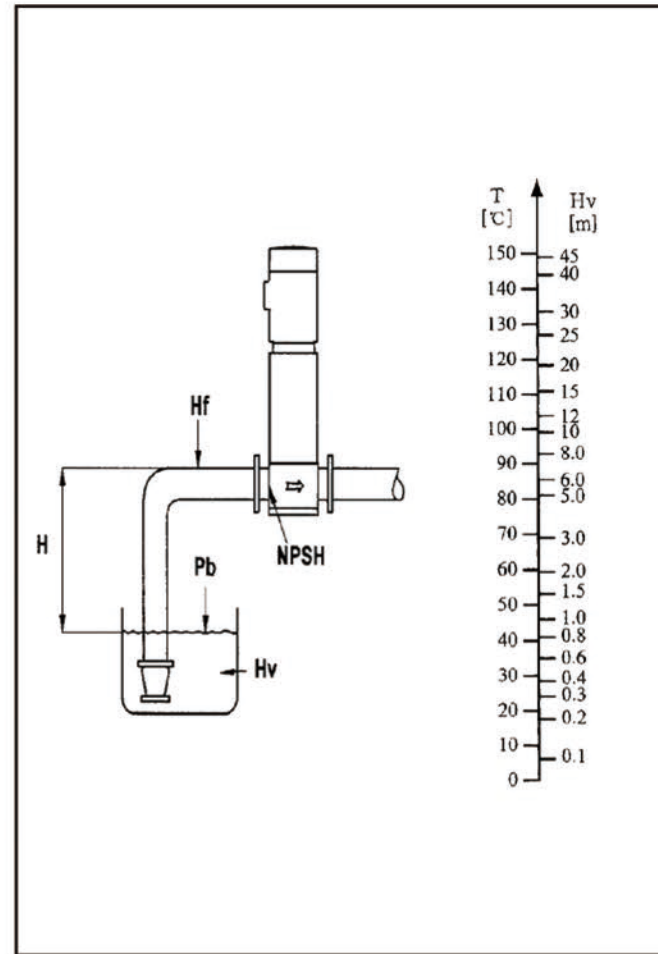

**Operation in parallel**

- Connection several pumps in parallel running will be much more benefit than running a single pump.
- Increasing the possibility of water supply when one pump is in failure, only part of the system flow is effected.
- Two pumps or more can be connected in parallel running if necessary.

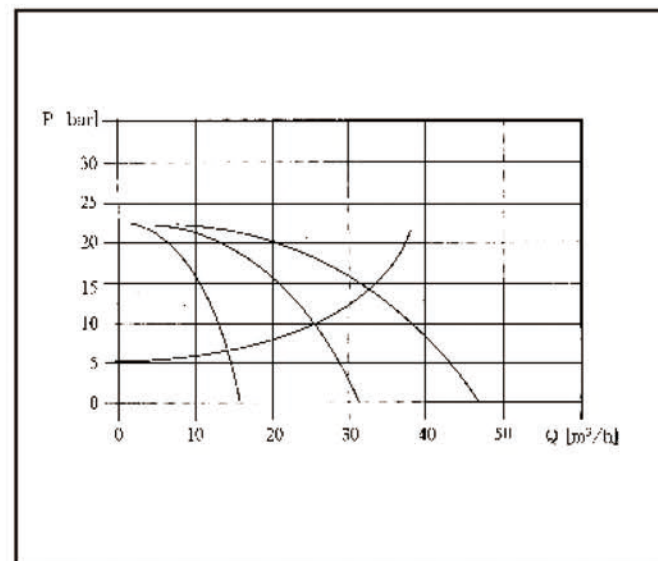

**Curve description**

× U E 3/4 General Data

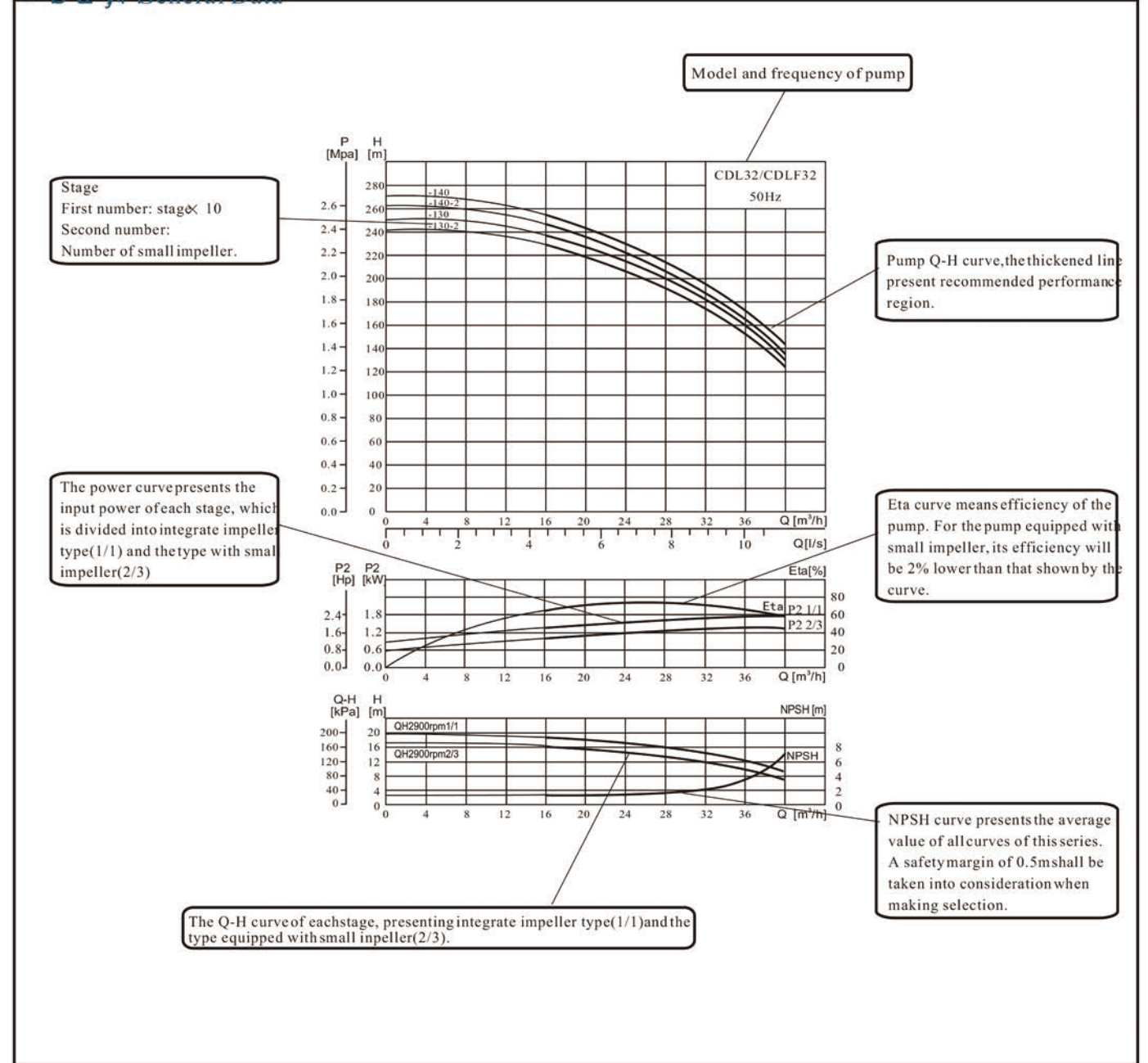

**Performance curve**

Following conditions are suitable for the performance curves shown bellow:

- All the performance curves are based on the measured values of a motor 3×380V at a constant speed of 2900rpm.
- Curve tolerance in conformity with ISO9906.
- Measure is done with 20°C air-free water, kinematic viscosity of 1mm²/sec.
- The operation of pump shall refer to the performance region indicated by the thickened curve to prevent overheating due to too small flow rate or overload of motor due to too large flow rate.



CDLF1,2,3,4,5

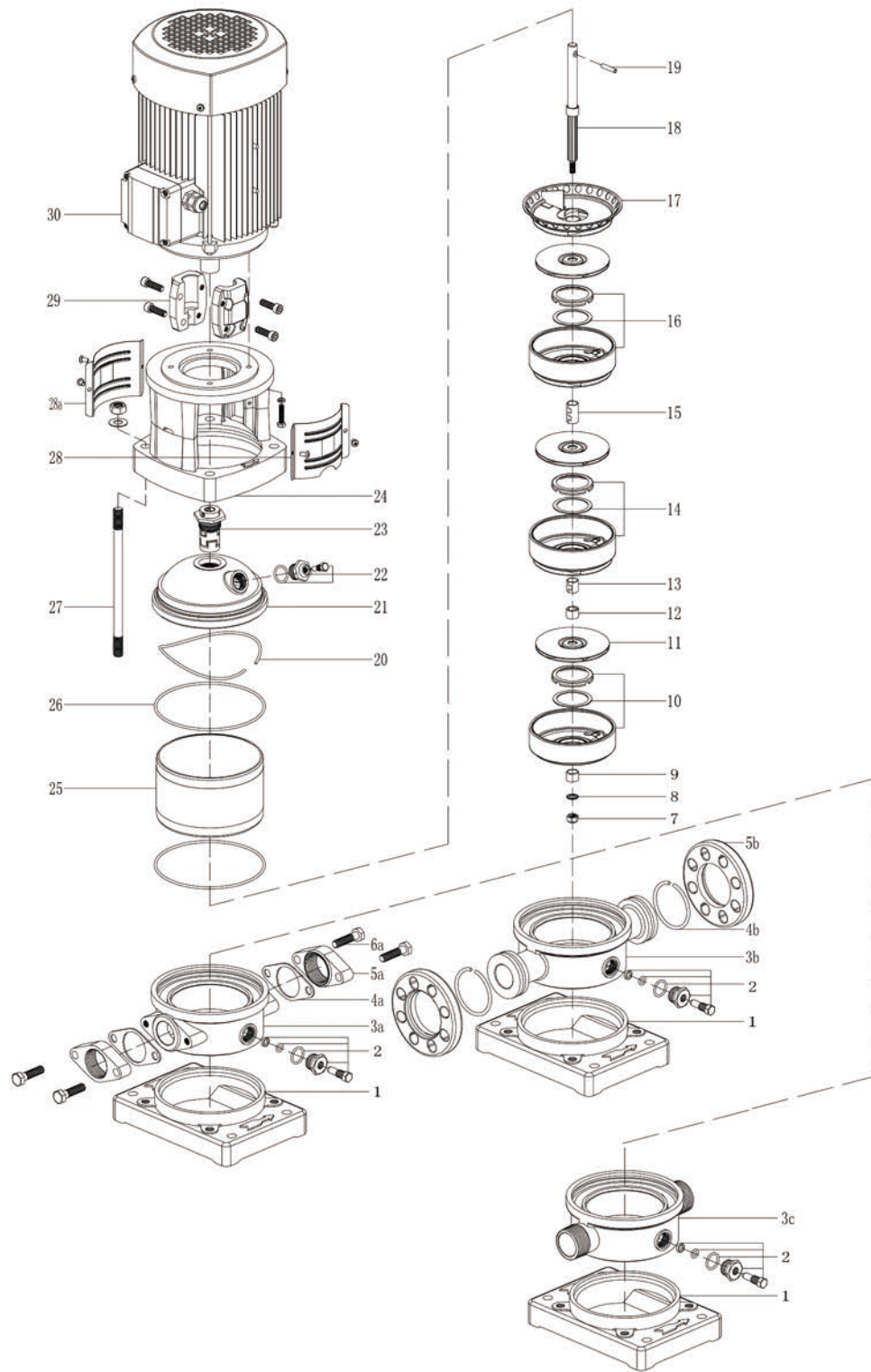

- 1 Base frame
- 2 By-pass Valve
- 3a Oval type inlet/outlet section
- 3b Flange type inlet/outlet section
- 3c Thread type inlet/outlet section
- 4a Gasket
- 4b Snap ring
- 5a Oval flange
- 5b Flange
- 6a Bolt
- 7 Lock nut
- 8 Gasket
- 9 Gland
- 10 Inducer
- 11 Impeller
- 12 Bearing
- 13 Bearing spacing pipe
- 14 Bearing diffuser
- 15 Impeller spacing pipe
- 16 Diffuser
- 17 Top diffuser
- 18 Shaft
- 19 Pin
- 20 Waveshape spring
- 21 Pump head
- 22 Air vent valve
- 23 Mechanical seal
- 24 Bracket
- 25 Out cylinder
- 26 O-ring
- 27 Stay bolt
- 28 Coupling guard
- 28a Coupling guard (No gap)
- 29 Coupling
- 30 Motor

CDLF8,12,16,20

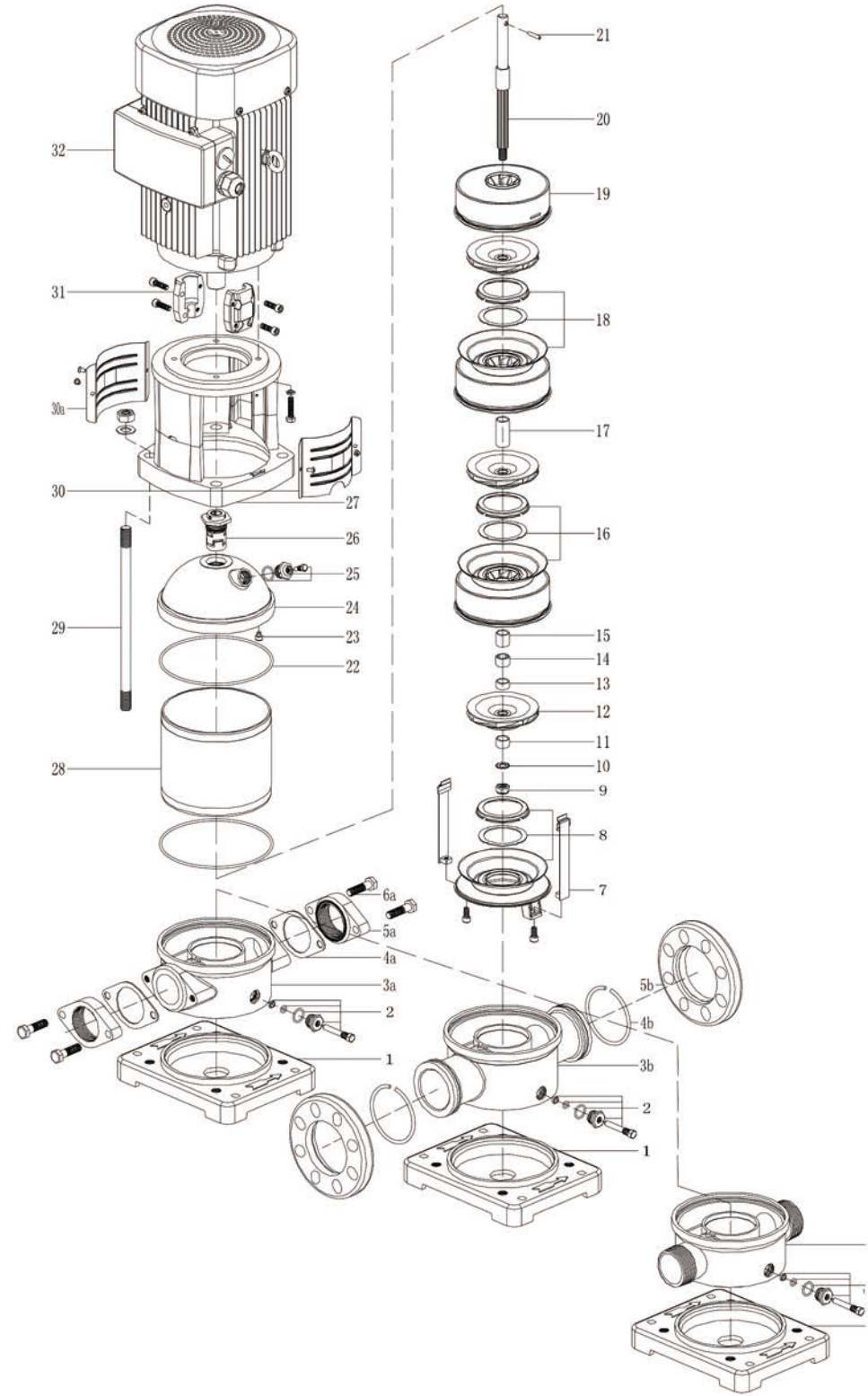

- 1 Base frame
- 2 By-pass Valve
- 3a Oval type inlet/outlet section
- 3b Flange type inlet/outlet section
- 3c Thread type inlet/outlet section
- 4a Gasket
- 4b Snap ring
- 5a Oval flange
- 5b Flange
- 6a Bolt
- 7 Taut band
- 8 Inducer
- 9 Lock nut
- 10 Gasket
- 11 Gland
- 12 Impeller
- 13 Short bearing spacing pipe
- 14 Bearing
- 15 Long bearing spacing pipe
- 16 Bearing diffuser
- 17 Impeller spacing pipe
- 18 Diffuser
- 19 Top diffuser
- 20 Shaft
- 21 Pin
- 22 O-ring
- 23 Gasket
- 24 Pump head
- 25 Air vent valve
- 26 Mechanical seal
- 27 Bracket
- 28 Out cylinder
- 29 Stay bolt
- 30 Coupling guard
- 30a Coupling guard (No gap)
- 31 Coupling
- 32 Motor



CDLF32,42,65,85

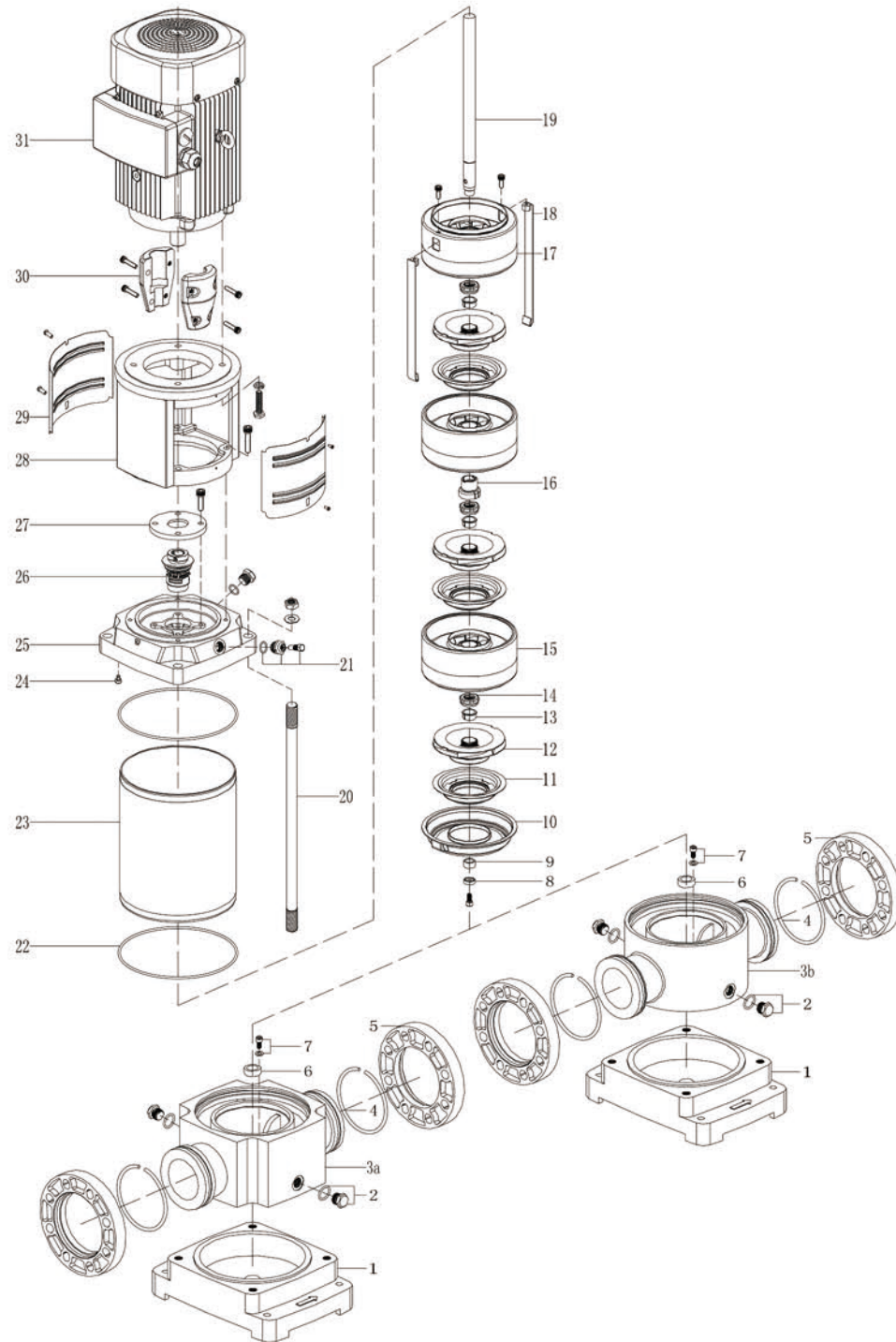

- 1 Base frame
- 2 By-pass Valve
- 3a Cast iron inlet/outlet section
- 3b Stainless steel inlet/outlet section
- 4 Snap ring
- 5 Flange
- 6 Bottom bearing housing
- 7 Lock bolt
- 8 Gland
- 9 Bearing
- 10 Inducer
- 11 Retainer
- 12 Impeller
- 13 Taper sleeve
- 14 Impeller nut
- 15 Diffuser
- 16 Intermediate bearing
- 17 Top diffuser
- 18 Taut band
- 19 Shaft
- 20 Stay bolt
- 21 Air vent valve
- 22 O-ring
- 23 Out cylinder
- 24 Gasket
- 25 Pump head
- 26 Mechanical seal
- 27 Seal mat
- 28 Bracket
- 29 Coupling guard
- 30 Coupling
- 31 Motor

CDLF120,150

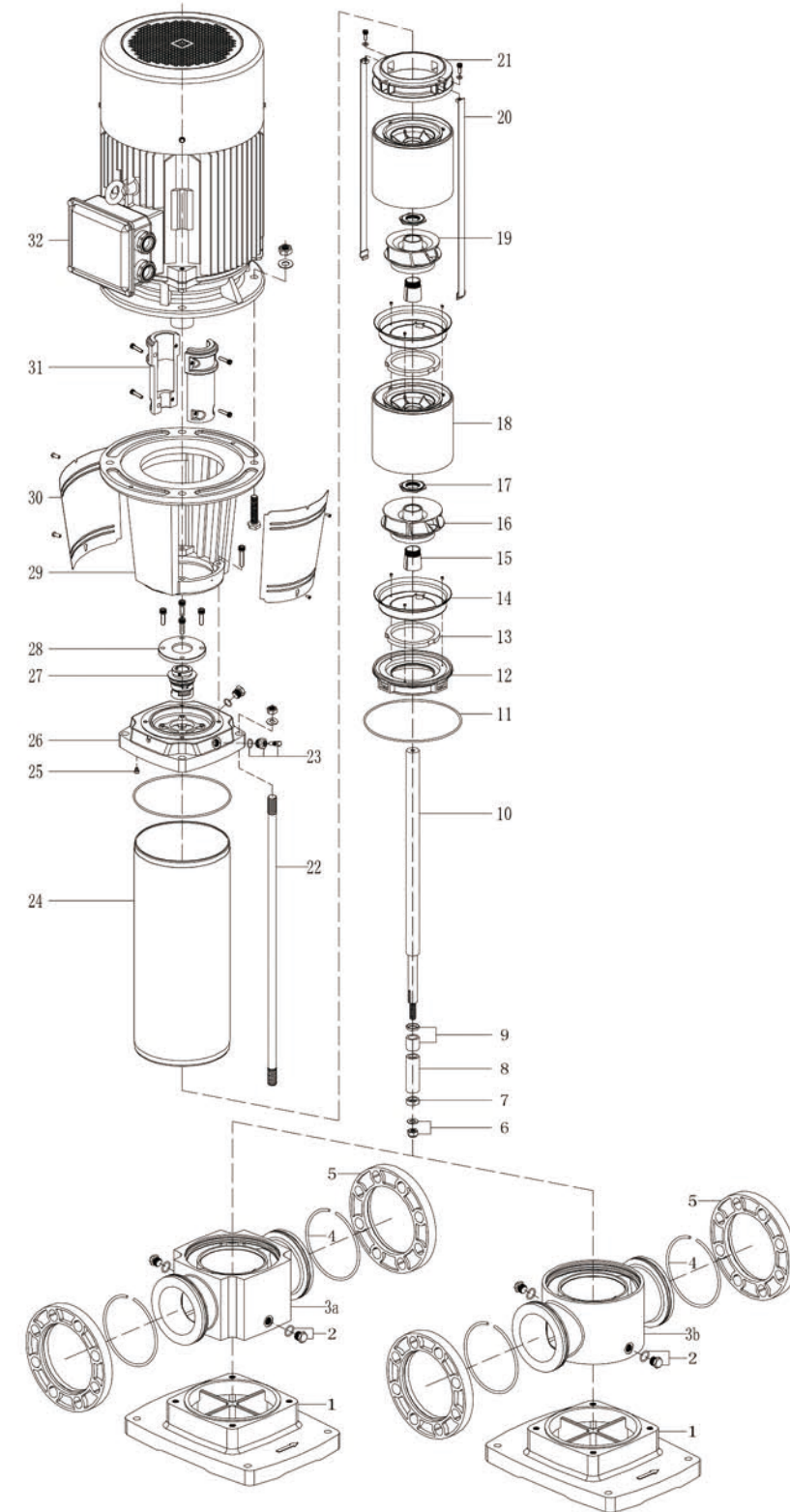

- 1 Base frame
- 2 By-pass Valve
- 3a Cast iron inlet/outlet section
- 3b Stainless steel inlet/outlet section
- 4 Snap ring
- 5 Flange
- 6 Lock nut
- 7 Gland
- 8 Impeller spacing pipe
- 9 Bearing
- 10 Shaft
- 11 O-ring
- 12 Inducer
- 13 O-ring
- 14 Retainer
- 15 Impeller sleeve
- 16 Impeller
- 17 Impeller nut
- 18 Bearing diffuser
- 19 Small impeller
- 20 Taut band
- 21 Water out section
- 22 Stay bolt
- 23 Air vent valve
- 24 Out cylinder
- 25 Gasket
- 26 Pump head
- 27 Mechanical seal
- 28 Seal mat
- 29 Bracket
- 30 Coupling guard
- 31 Coupling
- 32 Motor



Performance curve

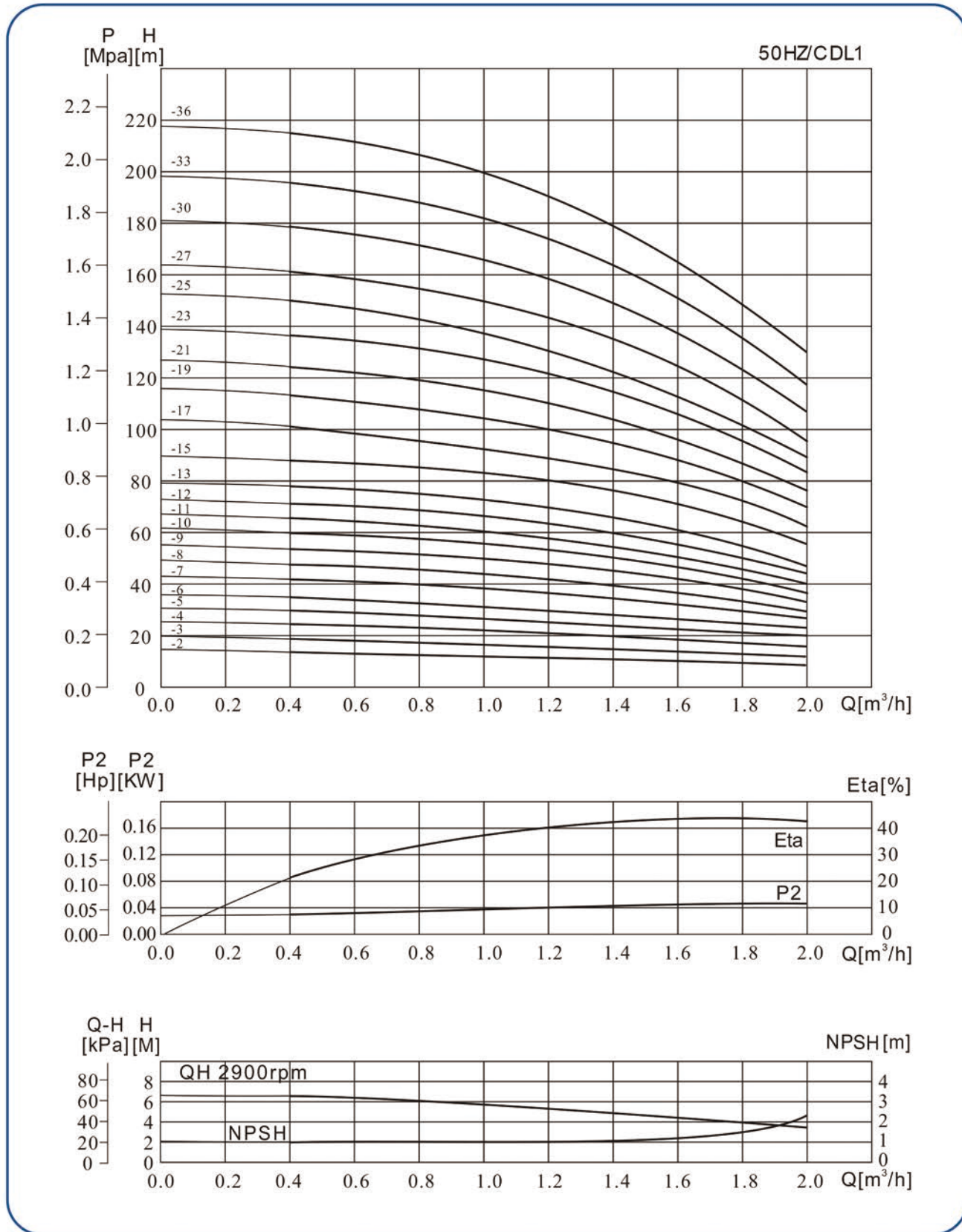

Installation sketch

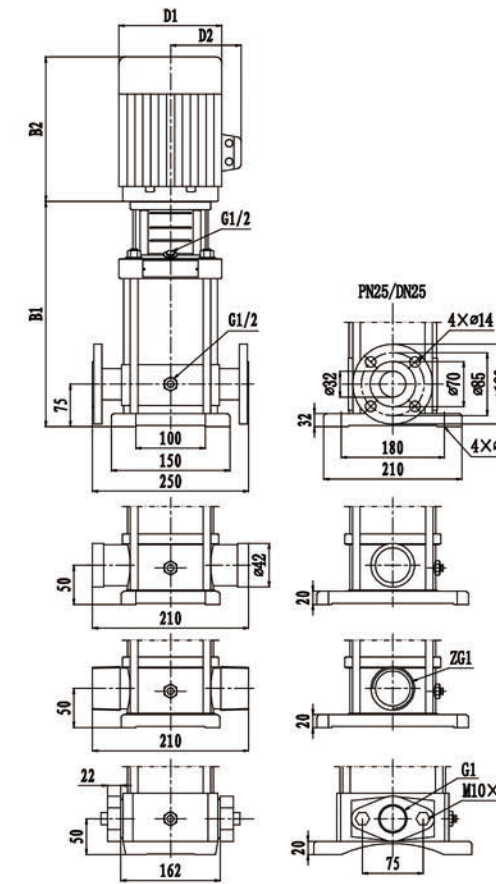

size and weight

Model	Size(mm)					Weight (kg)
	B1	B2	B1+B2	D1	D2	
CDLF1-20	258	210	468	148	117	20
CDLF1-30	276	210	486	148	177	20
CDLF1-40	294	210	504	148	117	20
CDLF1-50	312	210	522	148	117	20
CDLF1-60	330	210	540	148	117	20
CDLF1-70	348	210	558	148	117	20
CDLF1-80	366	210	576	148	117	22
CDLF1-90	384	210	594	148	117	22
CDLF1-100	402	210	612	148	117	22
CDLF1-110	420	210	630	148	117	22
CDLF1-120	448	245	693	170	142	25
CDLF1-130	466	245	711	170	142	25
CDLF1-150	502	245	747	170	142	25
CDLF1-170	538	245	783	170	142	28
CDLF1-190	574	245	819	170	142	28
CDLF1-210	610	245	855	170	142	30
CDLF1-230	646	245	891	170	142	33
CDLF1-250	692	290	982	190	155	40
CDLF1-270	728	290	1018	190	155	40
CDLF1-300	782	290	1072	190	155	40
CDLF1-330	836	290	1126	190	155	45
CDLF1-360	890	290	1180	190	155	45

Performance table

Model	Motor(kw)	Q (m³/h)	H (m)									
			0.4	0.6	0.8	1.0	1.2	1.4	1.6	1.8	2.0	
CDLF1-20	0.37	13	12.5	12	11.5	11	10.5	10	9.5	9		
CDLF1-30	0.37	19	18	17.5	17	16.5	16	15	14	12		
CDLF1-40	0.37	24	23.5	23	22.5	21.5	21	19	18	16		
CDLF1-50	0.37	30	29.6	29	28	27	26	24	22	20		
CDLF1-60	0.37	36	35.5	35	33.5	33	31	28	26	23		
CDLF1-70	0.37	42	41	40.5	39	38	36	33	30	27		
CDLF1-80	0.55	48	47	46	45	43	41	38	34	30		
CDLF1-90	0.55	54	53	52	51	49	46	43	39	33		
CDLF1-100	0.55	60	59	58	57	54	51	48	43	36		
CDLF1-110	0.55	66	65	63	61	59	56	52	47	40		
CDLF1-120	0.75	72	71	69	67	64	61	57	51	44		
CDLF1-130	0.75	78	77	75	73	69	66	62	55	47		
CDLF1-150	0.75	89	88	86	84	79	76	71	63	55		
CDLF1-170	1.1	101	99	97	95	89	86	80	71	62		
CDLF1-190	1.1	113	110	108	106	99	96	89	79	69		
CDLF1-210	1.1	124	122	120	117	110	106	98	87	75		
CDLF1-230	1.1	137	133	131	128	121	116	107	96	82		
CDLF1-250	1.5	149	145	143	139	131	126	116	104	89		
CDLF1-270	1.5	161	157	155	150	141	136	125	112	95		
CDLF1-300	1.5	178	175	171	166	157	150	139	124	106		
CDLF1-330	2.2	196	192	188	183	173	165	154	137	118		
CDLF1-360	2.2	214	210	205	200	190	181	169	151	130		



Performance curve

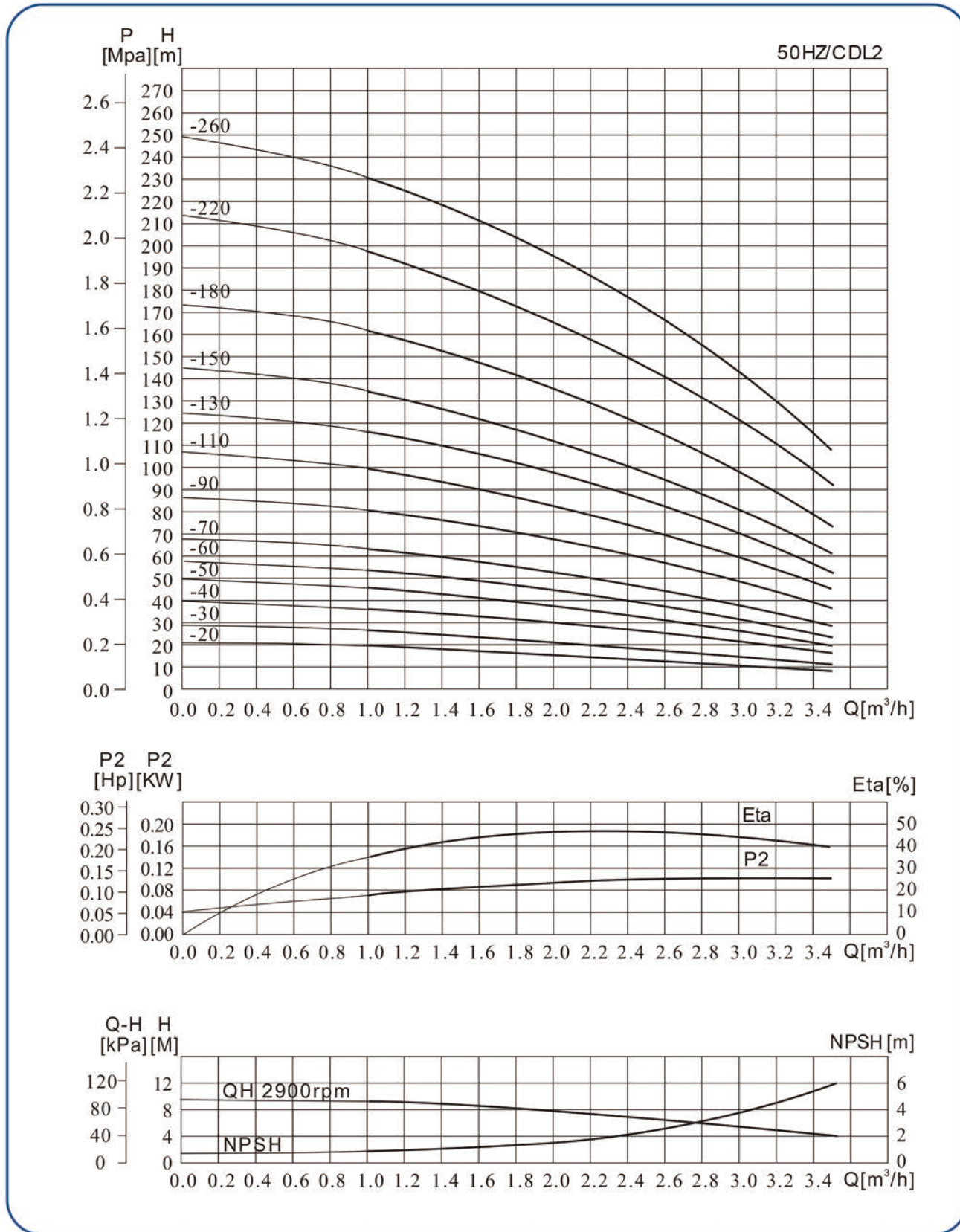

Installation sketch

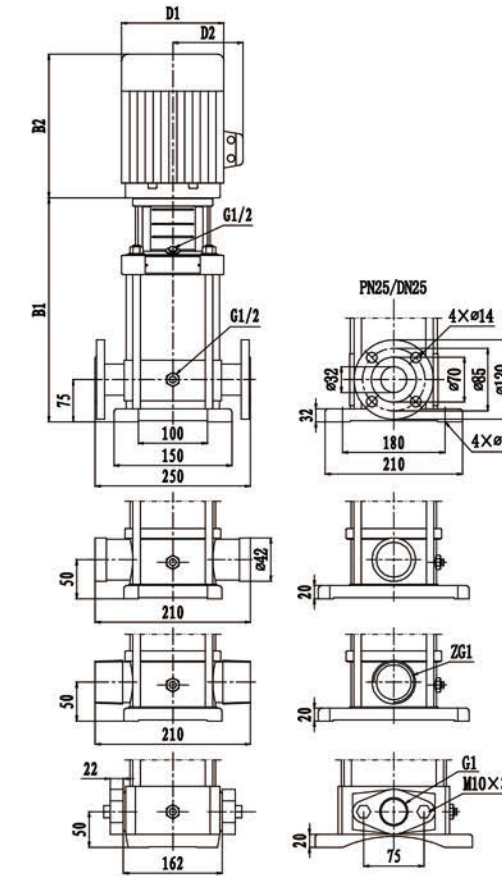

size and weight

Model	Size(mm)					Weight (kg)
	B1	B2	B1+B2	D1	D2	
CDLF2-20	251	235	486	145	110	20
CDLF2-30	269	235	504	145	110	20
CDLF2-40	287	235	522	145	110	20
CDLF2-50	305	235	540	145	110	20
CDLF2-60	323	235	558	145	110	25
CDLF2-70	341	235	576	145	110	25
CDLF2-90	377	235	612	170	150	30
CDLF2-110	413	235	648	170	150	30
CDLF2-130	465	280	739	170	150	35
CDLF2-150	500	280	775	170	150	35
CDLF2-180	550	280	829	180	155	40
CDLF2-220	621	280	901	180	155	45
CDLF2-260	703	340	1043	180	155	50

Performance table

Model	Motor(kw)	Q (m³/h)	H (m)								
			1	1.2	1.6	2.0	2.4	2.8	3.2	3.5	
CDLF2-20	0.37	18	17	16	15	13	12	10	8		
CDLF2-30	0.37	27	26	24	22	20	18	15	12		
CDLF2-40	0.55	36	35	32	30	27	24	20	16		
CDLF2-50	0.55	45	43	40	37	34	30	25	20		
CDLF2-60	0.75	53	52	48	45	40	36	30	24		
CDLF2-70	0.75	62	61	57	52	47	42	35	28		
CDLF2-80	1.1	71	69	65	60	54	48	40	33		
CDLF2-90	1.1	80	78	73	67	61	54	45	37		
CDLF2-100	1.1	89	87	81	75	68	60	50	41		
CDLF2-110	1.1	97	95	89	82	74	66	55	45		
CDLF2-120	1.5	106	104	97	90	81	72	60	49		
CDLF2-130	1.5	115	113	106	97	88	78	65	53		
CDLF2-140	1.5	124	122	114	105	95	84	70	57		
CDLF2-150	1.5	133	131	122	112	102	90	75	62		
CDLF2-160	1.5	141	140	130	120	108	96	80	66		
CDLF2-170	1.5	150	148	138	127	115	102	85	70		
CDLF2-180	2.2	159	157	146	135	122	108	90	74		
CDLF2-190	2.2	168	166	155	142	129	114	95	78		
CDLF2-200	2.2	177	174	163	150	136	120	100	82		
CDLF2-210	2.2	186	183	171	157	142	126	105	87		
CDLF2-220	2.2	195	192	179	165	149	132	110	91		
CDLF2-230	3.0	204	200	187	172	156	138	115	95		
CDLF2-240	3.0	213	209	195	180	163	144	120	99		
CDLF2-250	3.0	222	218	204	187	170	150	125	103		
CDLF2-260	3.0	231	226	212	195	177	156	130	107		



Performance curve

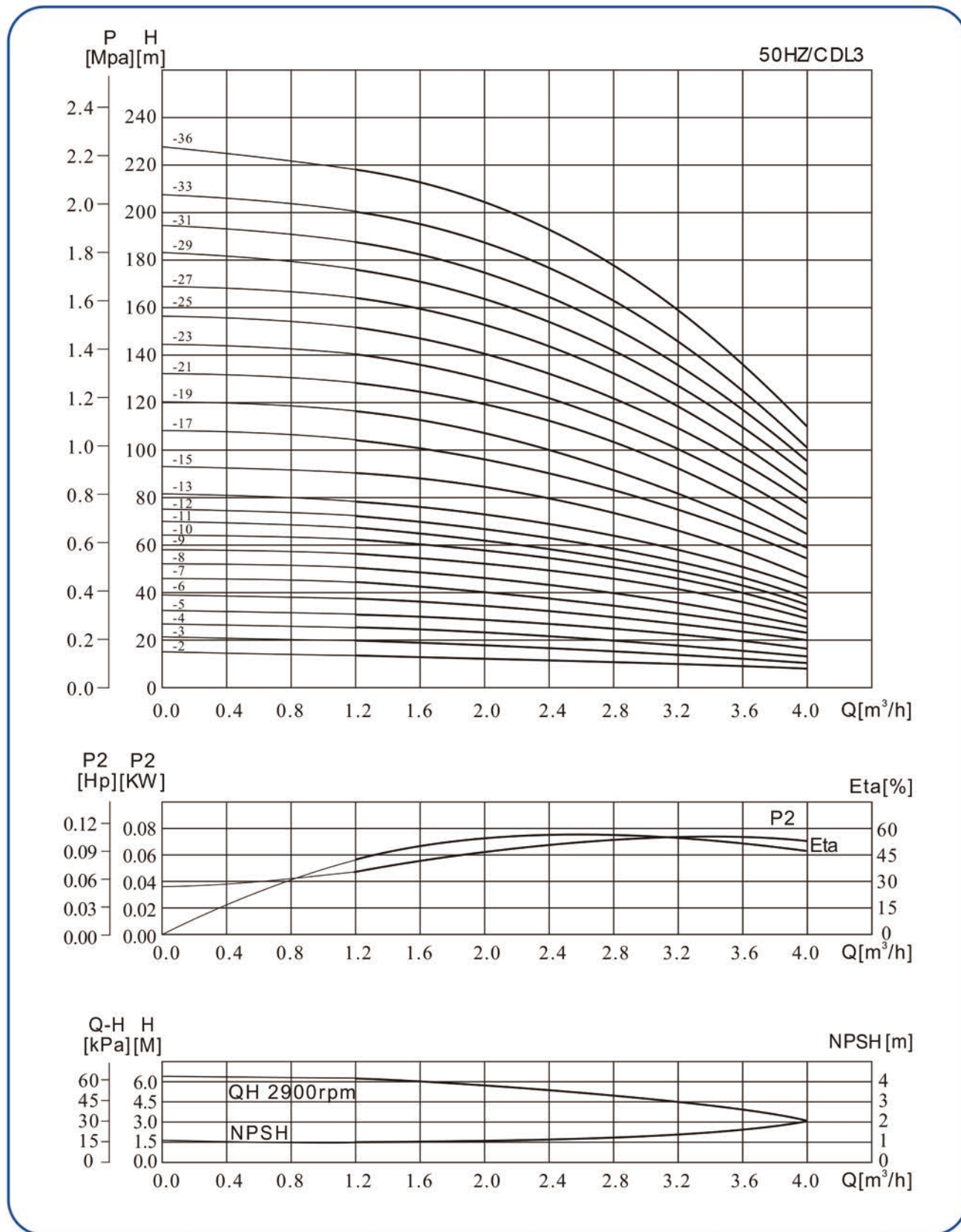

Installation sketch

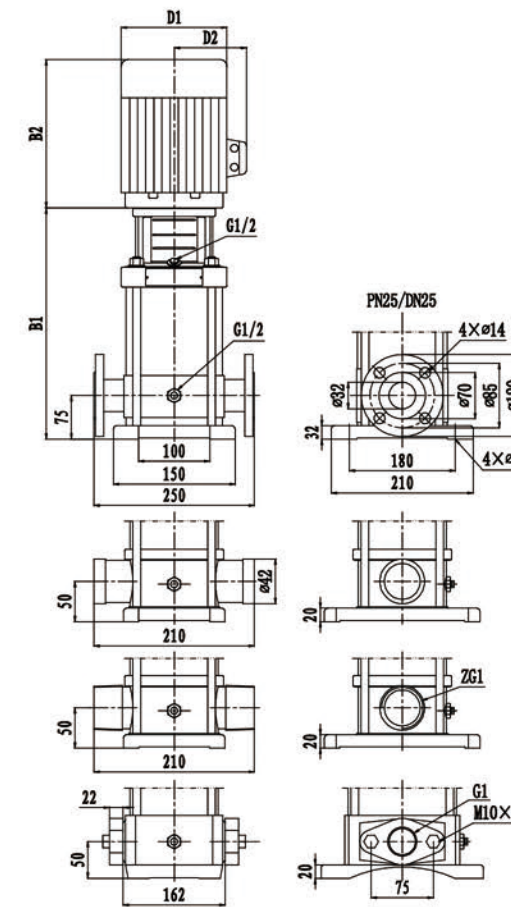

size and weight

Model	Size(mm)					Weight (kg)
	B1	B2	B1+B2	D1	D2	
CDLF3-20	258	210	468	148	117	20
CDLF3-30	276	210	486	148	117	20
CDLF3-40	294	210	504	148	117	20
CDLF3-50	312	210	522	148	117	20
CDLF3-60	330	210	540	148	117	22
CDLF3-70	348	210	558	148	117	22
CDLF3-80	376	245	621	170	142	22
CDLF3-90	394	245	639	170	142	22
CDLF3-100	412	245	657	170	142	22
CDLF3-110	430	245	675	170	142	25
CDLF3-120	448	245	693	170	142	25
CDLF3-130	466	245	711	170	142	25
CDLF3-150	502	245	747	170	142	25
CDLF3-170	548	290	838	190	155	30
CDLF3-190	584	290	874	190	155	35
CDLF3-210	620	290	910	190	155	35
CDLF3-230	656	290	946	190	155	40
CDLF3-250	692	290	982	190	155	40
CDLF3-270	728	290	1018	190	155	40
CDLF3-290	764	290	1054	190	155	40
CDLF3-310	810	315	1125	197	165	45
CDLF3-330	846	315	1161	197	165	50
CDLF3-360	900	315	1215	197	165	50

Performance table

Model	Motor(kw)	Q (m <sup>3</sup> /h)	H (m)											
			1.2	1.6	2	2.4	2.8	3	3.2	3.6	4.0			
CDLF3-20	0.37		12.5	11.5	11	10.5	10	9	8	7	6			
CDLF3-30	0.37		19	18.5	17.5	16.5	15	14	13	11	9			
CDLF3-40	0.37		25	24	23	21.5	20	19	18	15	12			
CDLF3-50	0.37		31	30	29	27	25	23	22	19	16			
CDLF3-60	0.55		36	35	34	32	30	28	27	23	19			
CDLF3-70	0.55		43	41	39	37	34	32	31	27	22			
CDLF3-80	0.75		49	47	45	43	39	37	35	31	25			
CDLF3-90	0.75		55	53	51	48	45	42	40	35	28			
CDLF3-100	0.75		61	59	57	54	50	47	45	39	31			
CDLF3-110	1.1		67	64	61	58	54	51	49	42	34			
CDLF3-120	1.1		73	70	67	63	58	55	52	45	37			
CDLF3-130	1.1		78	76	73	69	64	60	57	49	40			
CDLF3-150	1.1		90	88	84	79	73	69	66	57	46			
CDLF3-170	1.5		103	100	96	90	83	79	75	64	52			
CDLF3-190	1.5		115	112	107	100	92	88	83	72	58			
CDLF3-210	2.2		128	124	119	112	102	98	91	79	64			
CDLF3-230	2.2		140	135	130	122	112	107	100	86	70			
CDLF3-250	2.2		151	147	141	131	122	116	109	94	76			
CDLF3-270	2.2		164	159	152	143	132	124	117	101	82			
CDLF3-290	2.2		175	170	163	153	142	133	126	109	88			
CDLF3-310	3		187	182	175	165	153	142	135	116	94			
CDLF3-330	3		199	194	187	176	163	151	145	125	100			
CDLF3-360	3		218	212	204	192	178	168	159	137	109			



Performance curve

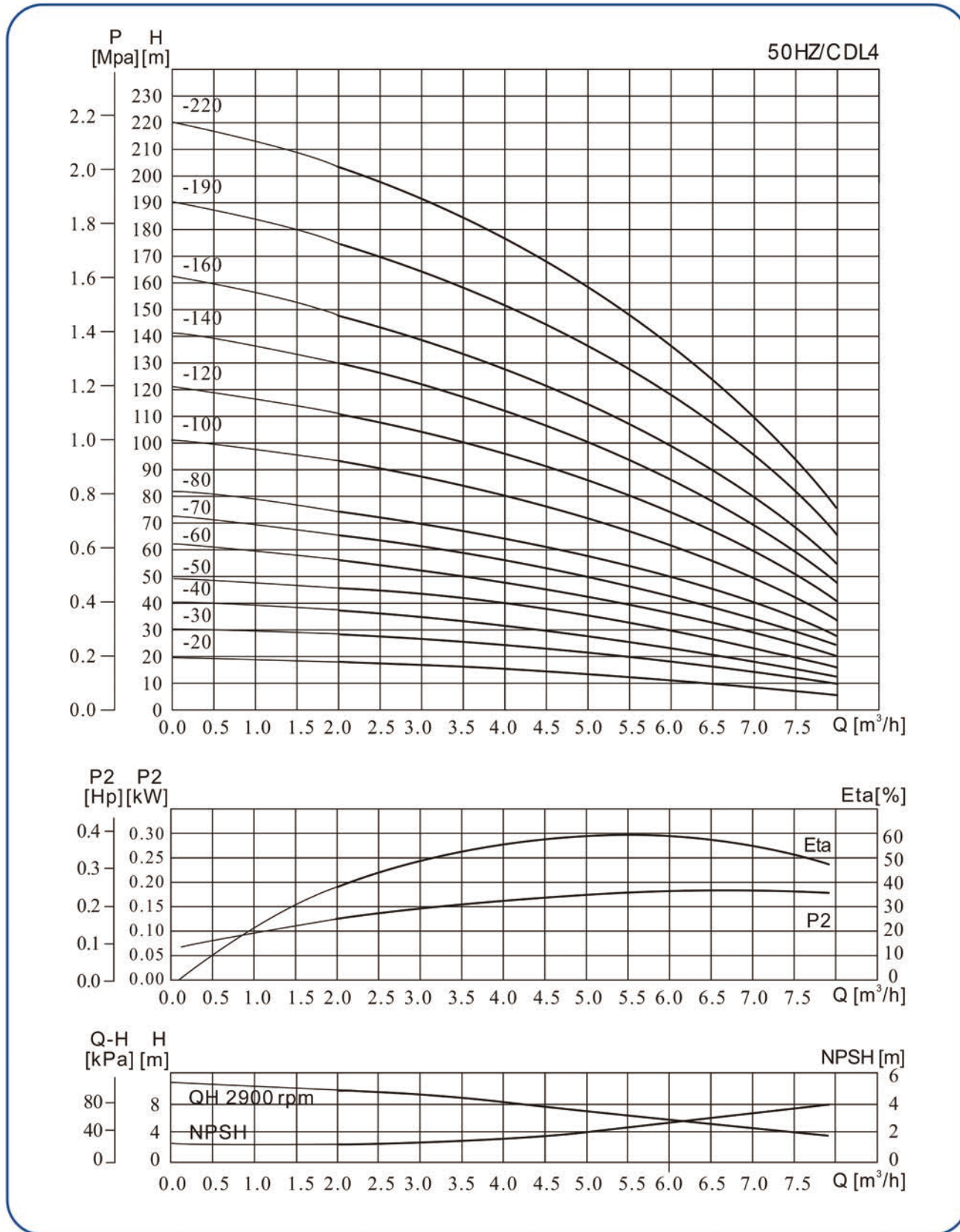

Installation sketch

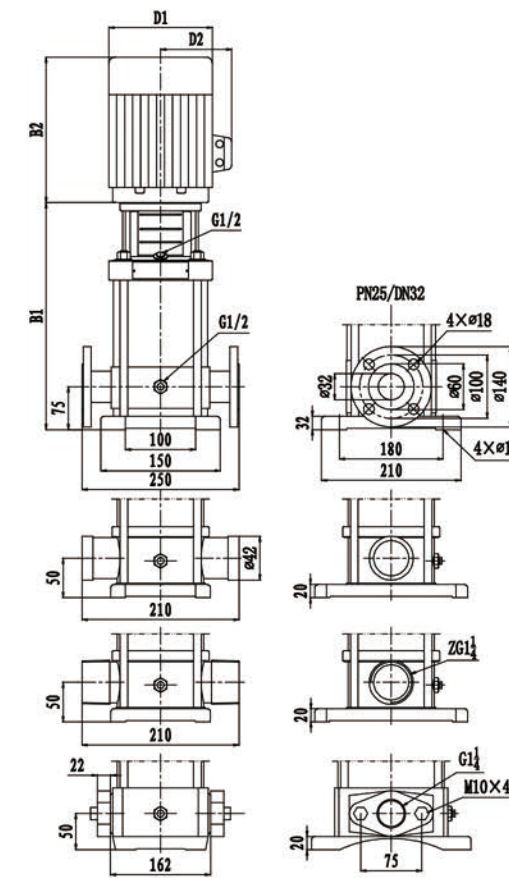

size and weight

Model	Size(mm)					Weight (kg)
	B1	B2	B1+B2	D1	D2	
CDLF4-20	266	235	501	145	110	20
CDLF4-30	293	235	528	145	110	20
CDLF4-40	320	235	555	145	110	20
CDLF4-50	347	235	582	170	150	20
CDLF4-60	374	235	609	170	150	20
CDLF4-70	411	280	691	170	150	25
CDLF4-80	438	280	718	170	150	25
CDLF4-100	492	280	772	170	150	30
CDLF4-120	546	280	826	180	155	30
CDLF4-140	610	340	950	180	155	35
CDLF4-160	664	340	1004	180	155	35
CDLF4-190	745	375	1120	210	180	40
CDLF4-220	826	375	1201	210	180	45

Performance table

Model	Motor(kw)	Q (m <sup>3</sup> /h)	1.5	2.0	3.0	4.0	5.0	6.0	7.0	8.0
CDLF4-20	0.37	H (m)	19	18	17	16	13	10	8	6
CDLF4-30	0.55		29	27	26	24	20	16	13	10
CDLF4-40	0.75		38	37	35	32	27	23	18	13
CDLF4-50	1.1		48	46	43	40	34	29	23	17
CDLF4-60	1.1		57	55	52	48	42	35	28	20
CDLF4-70	1.5		67	65	61	56	49	42	33	24
CDLF4-80	1.5		76	74	69	64	56	48	38	27
CDLF4-90	2.2		86	83	78	72	63	54	43	31
CDLF4-100	2.2		95	93	87	80	70	61	48	34
CDLF4-110	2.2		105	102	95	88	78	67	53	38
CDLF4-120	2.2		114	111	104	96	85	73	58	41
CDLF4-130	3.0		124	121	113	104	92	80	63	45
CDLF4-140	3.0		133	130	121	112	99	86	68	48
CDLF4-150	3.0		143	139	130	120	106	92	73	52
CDLF4-160	3.0		152	149	139	128	114	99	78	55
CDLF4-170	4.0		162	158	147	136	121	105	83	59
CDLF4-180	4.0	171	167	156	144	128	111	88	62	
CDLF4-190	4.0	181	177	165	152	135	118	93	66	
CDLF4-200	4.0	190	186	173	160	142	124	98	69	
CDLF4-210	4.0	200	195	182	168	150	130	103	73	
CDLF4-220	4.0	209	204	191	176	157	136	108	76	



Performance curve

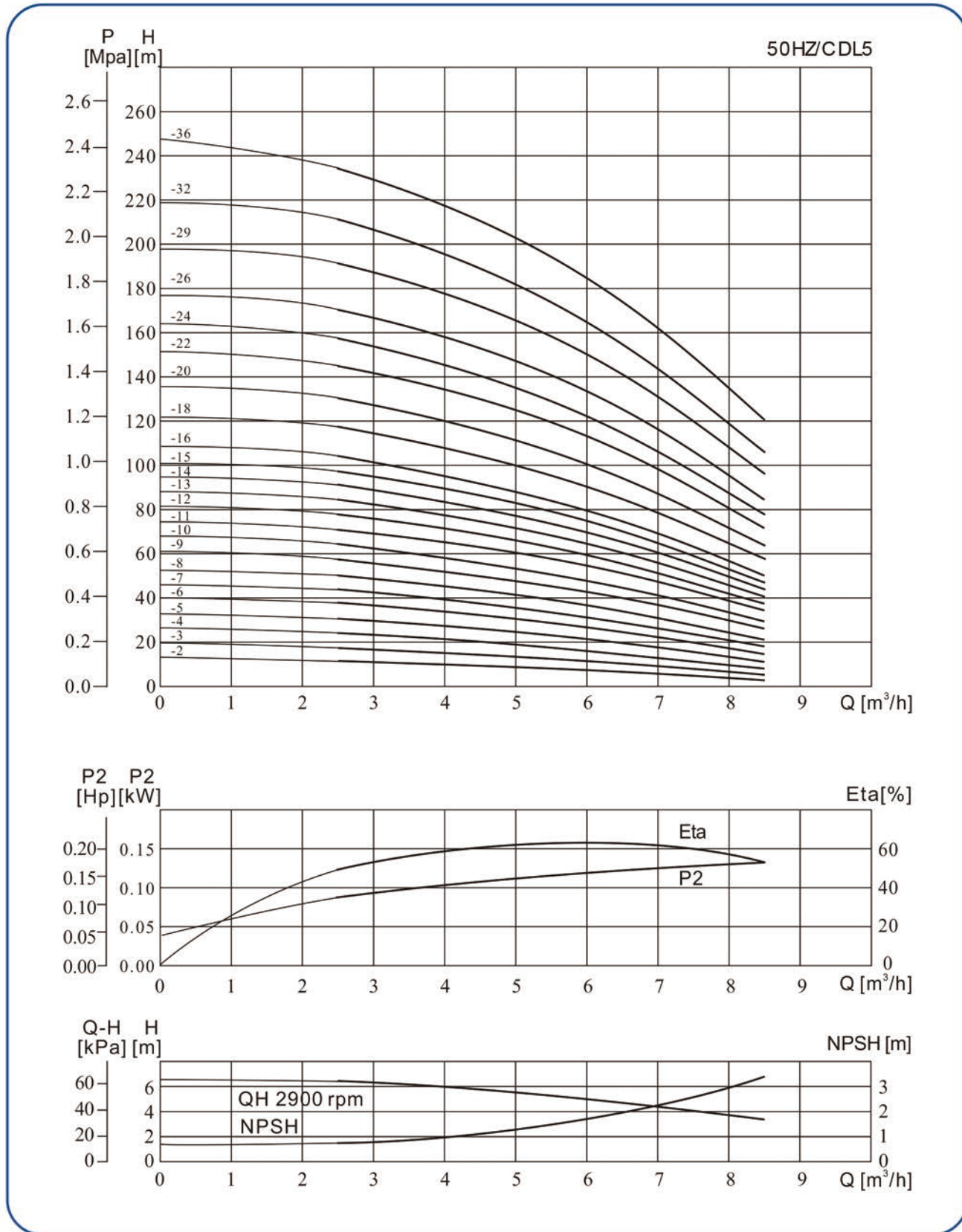

Installation sketch

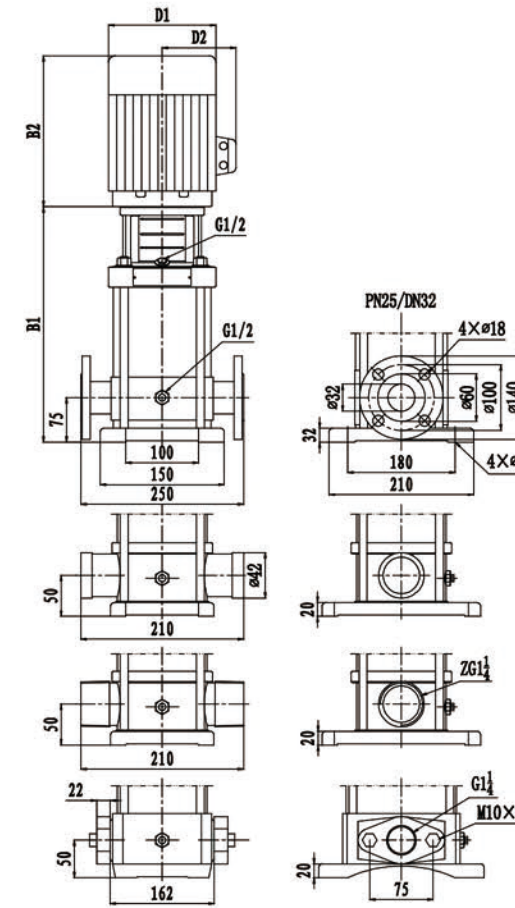

size and weight

Model	Size(mm)					Weight (kg)
	B1	B2	B1+B2	D1	D2	
CDLF5-20	279	191	470	141	109	23
CDLF5-30	306	191	497	141	109	24
CDLF5-40	333	191	524	141	109	25
CDLF5-50	366	231	597	141	109	27
CDLF5-60	393	231	624	141	109	30
CDLF5-70	420	231	651	141	109	30
CDLF5-80	447	231	678	141	109	31
CDLF5-90	490	281	771	178	110	38
CDLF5-100	517	281	798	178	110	39
CDLF5-110	544	321	865	178	110	40
CDLF5-120	571	321	892	178	110	41
CDLF5-130	598	321	919	178	110	41
CDLF5-140	625	321	946	178	110	45
CDLF5-150	652	321	973	178	110	43
CDLF5-160	679	321	1000	178	110	43
CDLF5-180	737	335	1072	198	120	48
CDLF5-200	791	335	1126	198	120	50
CDLF5-220	845	372	1217	220	134	62
CDLF5-240	899	372	1271	220	134	63
CDLF5-260	953	372	1325	220	134	64
CDLF5-290	1034	372	1406	220	134	66
CDLF5-320	1145	391	1536	220	134	82
CDLF5-360	1253	391	1644	220	134	84

Performance table

Model	Motor(kw)	Q (m³/h)	H (m)							
			2.5	3	4	5	6	7	8	
CDLF5-20	0.37		11.5	11.2	10.3	9.3	7	6.2	4.2	
CDLF5-30	0.55		18	17.5	16.5	15	13.5	11	8.5	
CDLF5-40	0.55		24.5	24	23	21	19	16	13	
CDLF5-50	0.75		31	30.5	29	27	24.5	21	17	
CDLF5-60	1.1		37.5	37	35.5	33	30	26	21	
CDLF5-70	1.1		43.5	43	41	38	34.5	30	24	
CDLF5-80	1.1		50	49	47	43.5	39.5	34	27.5	
CDLF5-90	1.5		55.7	55	52.5	49	44	38	31	
CDLF5-100	1.5		62	61	58	54	48.5	42	34	
CDLF5-110	2.2		68	67	64	59.5	54	46.5	38	
CDLF5-120	2.2		74	73	70	65	59	51	41.5	
CDLF5-130	2.2		80.5	79	76	71	64	55	45	
CDLF5-140	2.2		86.5	85	82	76.5	69	60	49	
CDLF5-150	2.2		93	91.5	87.5	82	74	64.5	53	
CDLF5-160	2.2		99	97.5	93.5	87.5	79.5	69	56	
CDLF5-180	3.0		112	110	105	98.5	89.5	77.5	64	
CDLF5-200	3.0		124	122	117	110	99.5	86.5	71	
CDLF5-220	4.0		136	135	129	121	110	95	78	
CDLF5-240	4.0		149	147	141	132	120	104	85.5	
CDLF5-260	4.0		161	159	153	143	130	113	93	
CDLF5-290	4.0		180	178	171	160	145	126	104	
CDLF5-320	5.5		199	196	188	177	161	140	115	
CDLF5-360	5.5		224	221	212	199	181	158	130	



Performance curve

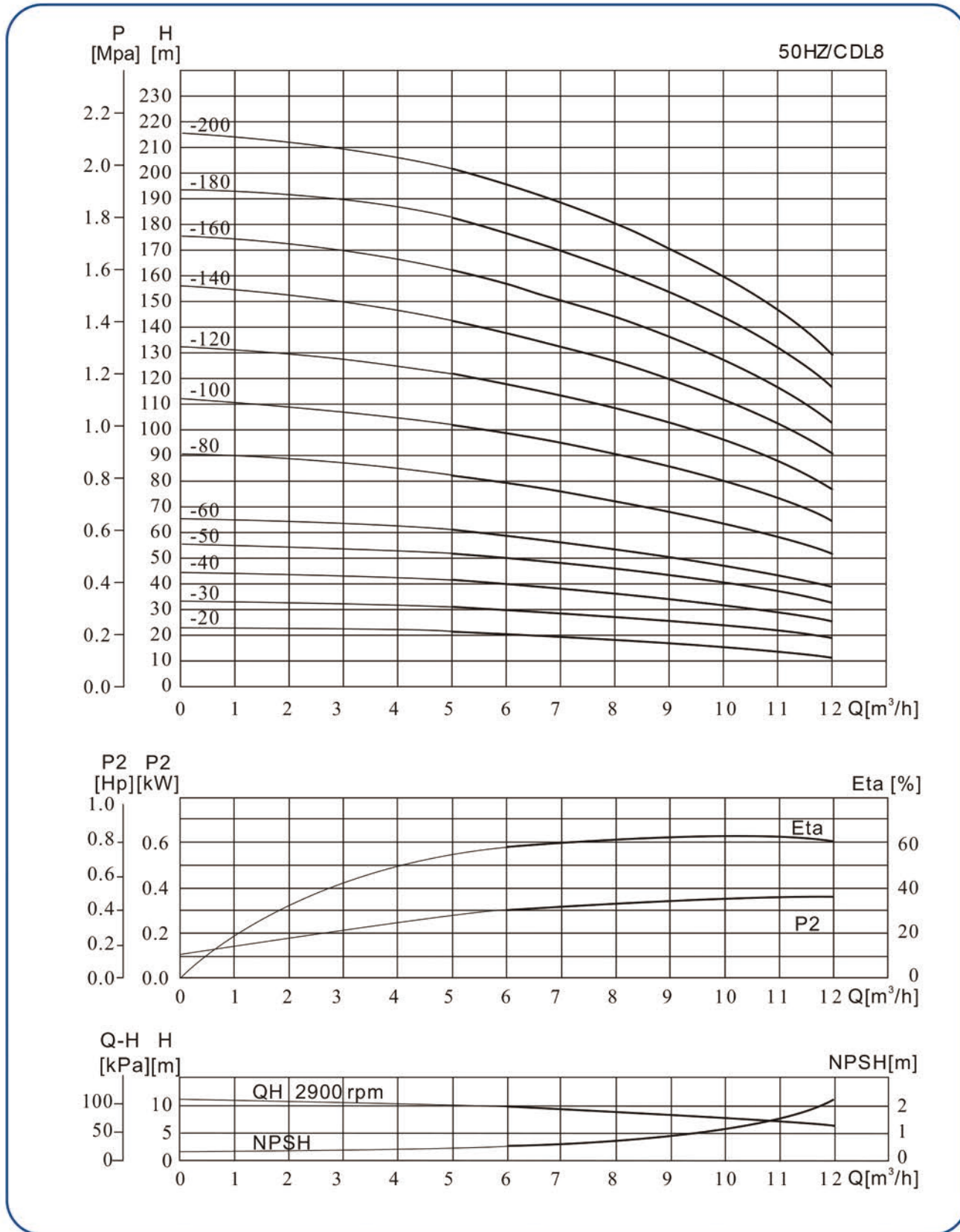

Installation sketch

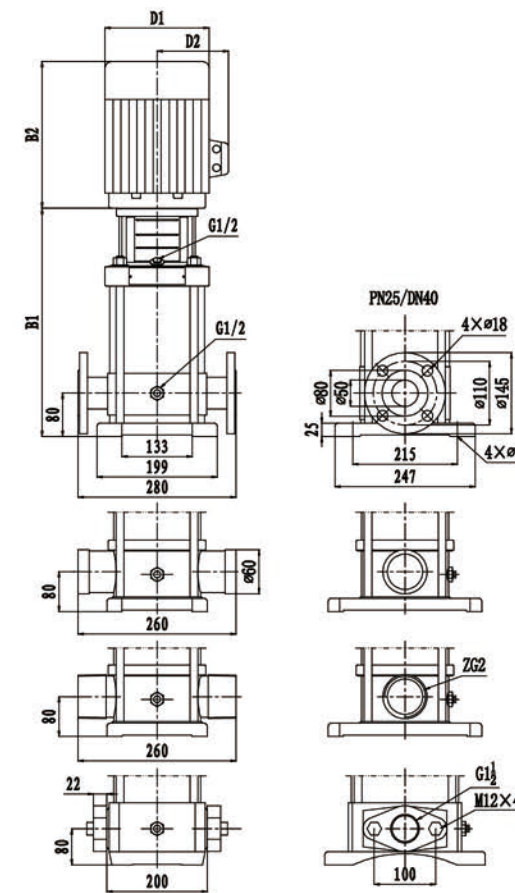

size and weight

Model	Size(mm)					Weight (kg)
	B1	B2	B1+B2	D1	D2	
CDLF8-20	360	235	595	145	110	25
CDLF8-30	390	235	625	170	150	30
CDLF8-40	430	280	710	170	150	30
CDLF8-50	460	280	740	180	155	40
CDLF8-60	490	280	770	180	155	40
CDLF8-80	560	340	900	180	155	45
CDLF8-100	620	375	995	210	180	55
CDLF8-120	680	375	1055	210	180	55
CDLF8-140	760	395	1155	250	210	80
CDLF8-160	820	395	1215	250	210	80
CDLF8-180	880	395	1275	250	210	90
CDLF8-200	940	395	1335	250	210	95

Performance table

Model	Motor(kw)	Q (m³/h)	5	6	7	8	9	10	11	12
CDLF8-20	0.75	H (m)	21	20	19	18	17	16	14	13
CDLF8-30	1.0		31	30	28	27	25	24	21	19
CDLF8-40	1.5		41	40	37	36	34	32	29	26
CDLF8-50	2.2		51	49	47	45	42	40	36	33
CDLF8-60	2.2		61	59	56	54	51	48	43	39
CDLF8-70	3.0		71	69	65	63	59	56	51	46
CDLF8-80	3.0		81	78	75	72	68	64	58	52
CDLF8-90	4.0		91	88	84	81	76	72	65	59
CDLF8-100	4.0		101	98	93	90	85	80	73	65
CDLF8-110	4.0		111	107	103	99	93	88	80	72
CDLF8-120	4.0		121	117	112	108	102	96	87	78
CDLF8-130	5.5		131	127	121	117	110	104	95	85
CDLF8-140	5.5	141	136	131	126	119	112	102	91	
CDLF8-150	5.5	151	146	140	135	127	120	109	98	
CDLF8-160	5.5	161	156	149	144	136	128	117	104	
CDLF8-170	7.5	171	165	159	153	144	136	124	111	
CDLF8-180	7.5	181	175	168	162	153	144	131	117	
CDLF8-190	7.5	191	185	177	171	161	152	139	124	
CDLF8-200	7.5	201	195	187	180	170	160	146	130	



Performance curve

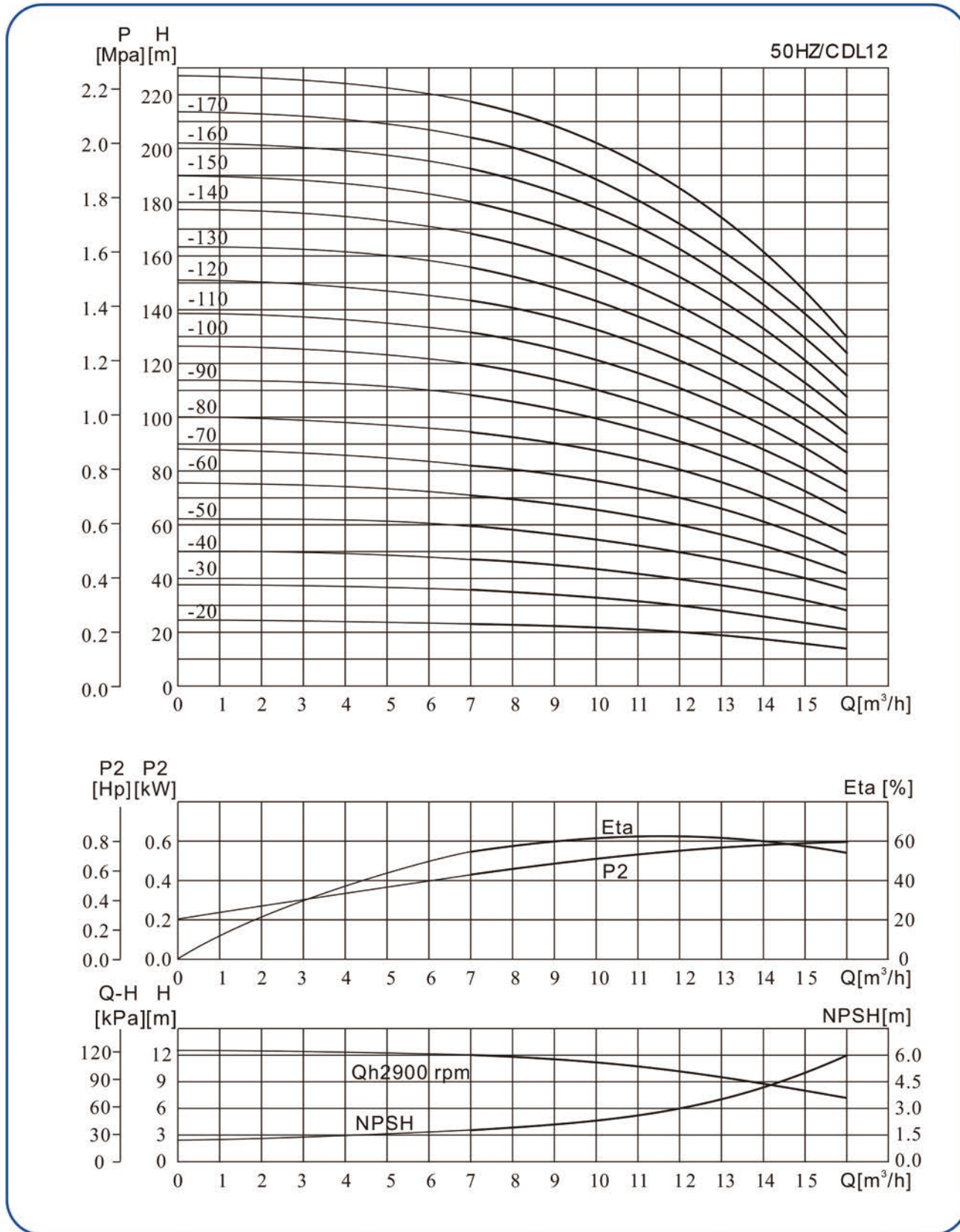

Installation sketch

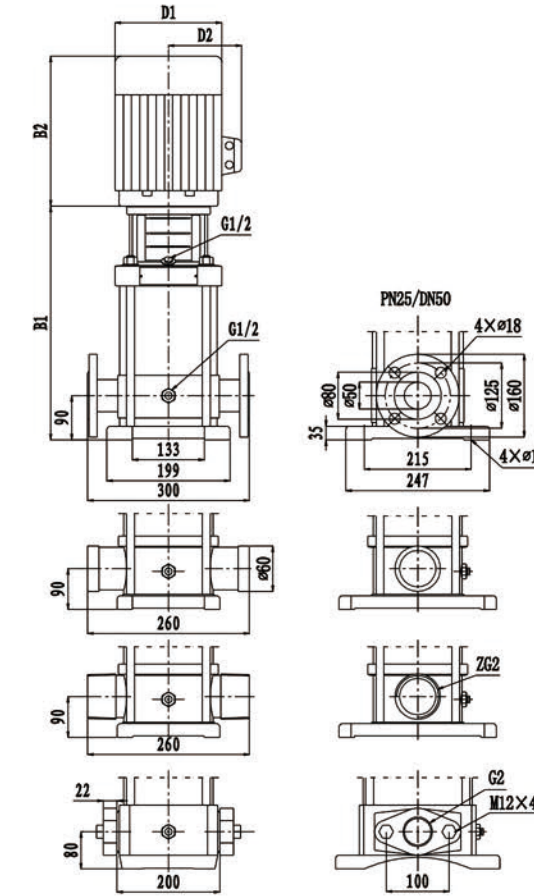

size and weight

Model	Size(mm)					Weight (kg)
	B1	B2	B1+B2	D1	D2	
CDLF12-20	367	290	657	190	155	39
CDLF12-30	397	290	687	190	155	43
CDLF12-40	437	315	752	197	165	51
CDLF12-50	467	315	782	197	165	53
CDLF12-60	497	335	832	230	188	61
CDLF12-70	547	430	977	260	208	73
CDLF12-80	577	430	1007	260	208	74
CDLF12-90	607	430	1037	260	208	76
CDLF12-100	637	430	1067	260	208	83
CDLF12-120	697	430	1127	260	208	87
CDLF12-140	845	490	1335	330	255	157
CDLF12-160	905	490	1395	330	255	161
CDLF12-180	965	490	1455	330	255	164

Performance table

Model	Motor(kw)	Q (m³/h)	7	8	9	10	11	12	13	14	15	16
CDLF12-20	1.5	H (m)	23.5	23	22.5	22	21	20	18.5	17	15.5	14
CDLF12-30	2.2		35.5	35	34	33	31.5	30	28	26	23.5	21
CDLF12-40	3		47	46	45	44	42	40	37	34	31	28
CDLF12-50	3		59.5	58	56.5	55	52.5	50	46.5	43	39	35
CDLF12-60	4		71.5	70	68	66	63	60	56	52	47	42
CDLF12-70	5.5		83.5	82	79.5	77	73.5	70	65.5	61	55	49
CDLF12-80	5.5		95.5	94	91	88	84	80	75	70	63	56
CDLF12-90	5.5		108	106	103	100	95.5	91	85	79	71.5	64
CDLF12-100	7.5		120	118	114.5	111	106	101	94.5	88	80	72
CDLF12-120	7.5		143.5	141	137	133	127	121	113.5	106	96	86
CDLF12-140	11		168	165	160	155	148	141	132.5	124	112	100
CDLF12-160	11		192.5	189	183.5	178	170	162	152	142	128.5	115
CDLF12-180	11		217	213	207.5	202	192.5	183	171.5	160	145	130



Performance curve

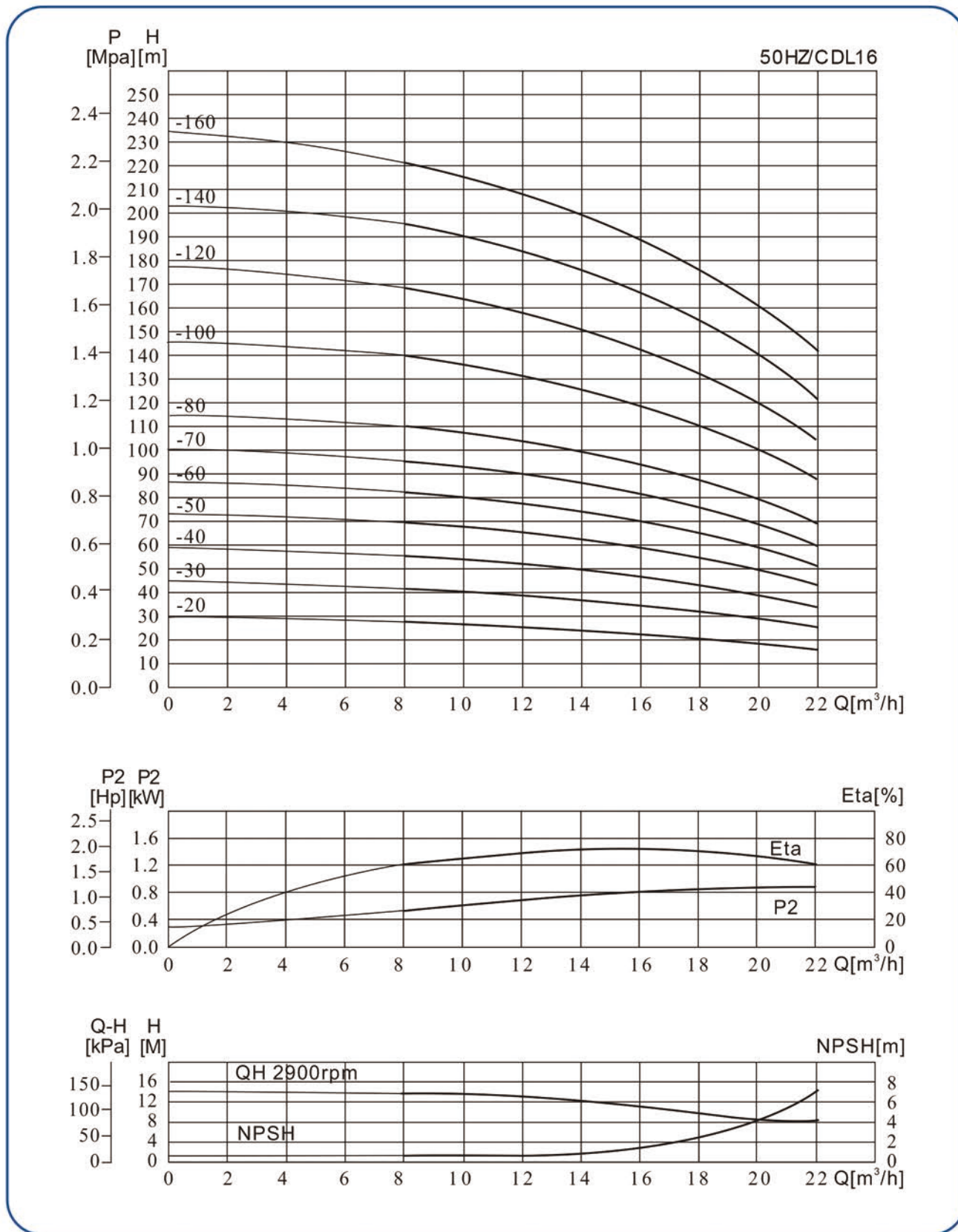

Installation sketch

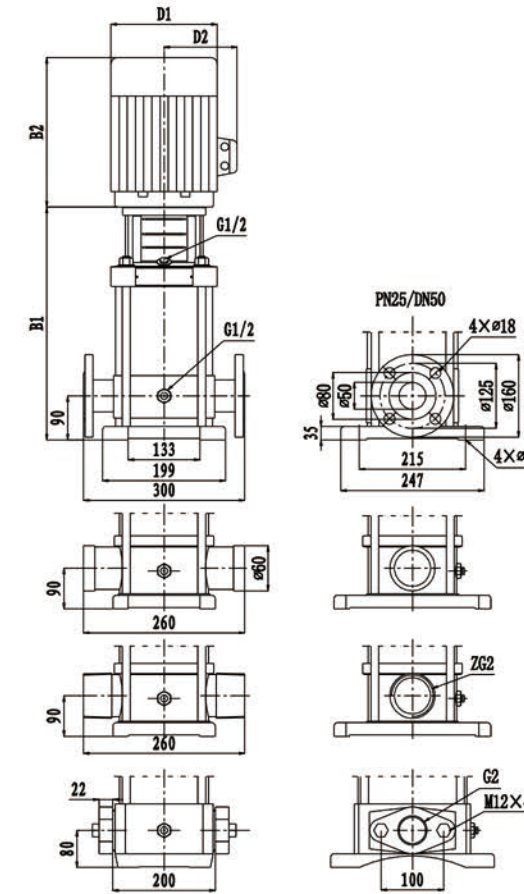

size and weight

Model	Size(mm)					Weight (kg)
	B1	B2	B1+B2	D1	D2	
CDLF16-20	400	280	680	180	155	40
CDLF16-30	455	340	795	180	155	50
CDLF16-40	500	375	875	210	180	55
CDLF16-50	565	395	960	250	210	70
CDLF16-60	610	395	1005	250	210	75
CDLF16-70	655	395	1050	250	210	80
CDLF16-80	700	395	1095	250	210	80
CDLF16-90	785	505	1290	250	210	140
CDLF16-100	830	505	1335	330	255	140
CDLF16-120	920	505	1425	330	255	145
CDLF16-140	1010	505	1515	330	255	165
CDLF16-160	1100	505	1605	330	255	170

Performance table

Model	Motor(kw)	Q (m³/h)	H (m)									
			8	10	12	14	16	18	20	22		
CDLF16-20	2.2		27	26	25	24	22	21	19	16		
CDLF16-30	3.0		41	40	38	37	34	32	26	25		
CDLF16-40	4.0		54	53	52	49	46	43	38	34		
CDLF16-50	5.5		68	67	65	62	58	54	48	43		
CDLF16-60	5.5		82	82	78	74	70	64	58	52		
CDLF16-70	7.5		96	95	91	87	82	76	69	61		
CDLF16-80	7.5		110	108	104	99	94	86	79	70		
CDLF16-90	11		124	121	117	112	106	98	90	79		
CDLF16-100	11		138	135	131	125	118	109	100	88		
CDLF16-110	11		152	148	144	137	130	121	110	96		
CDLF16-120	11		166	162	157	150	142	132	120	105		
CDLF16-130	15		180	176	170	162	154	144	130	114		
CDLF16-140	15		194	190	184	175	166	156	140	123		
CDLF16-150	15		208	203	196	187	178	166	150	132		
CDLF16-160	15		222	216	209	200	189	176	160	142		







Performance curve

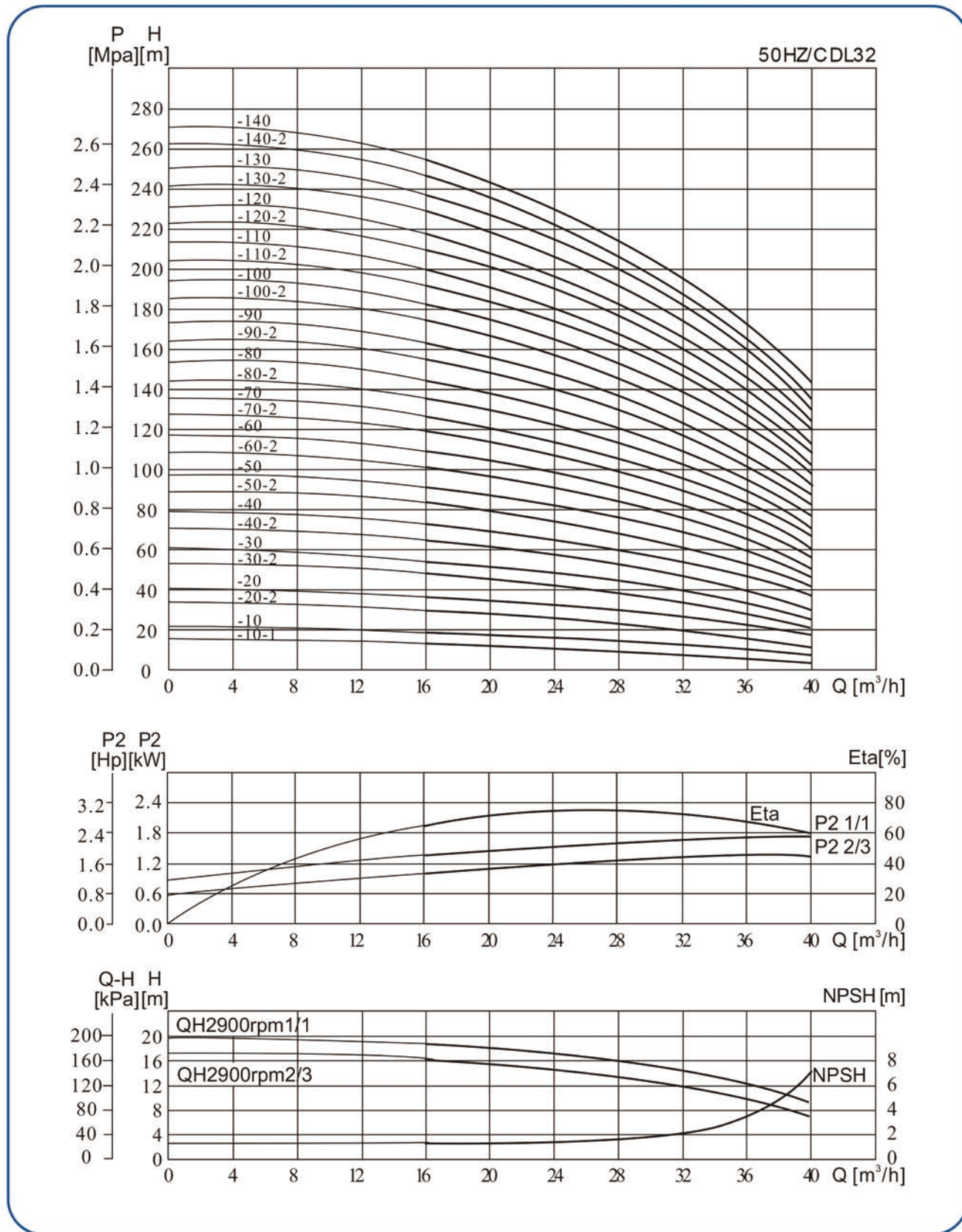

Installation sketch

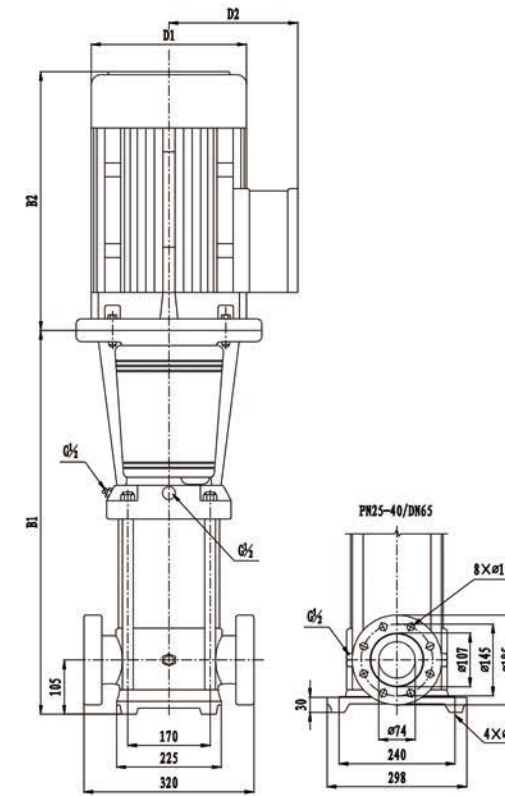

size and weight

Model	Size(mm)					Weight (kg)
	B1	B2	B1+B2	D1	D2	
CDLF32-10-1/CDLF32-10	505	290	795	190	155	71
CDLF32-20-2/CDLF32-20	575	315/335	890/910	197/230	165/188	84
CDLF32-30-2/CDLF32-30	645	430	1075	260	208	95
CDLF32-40-2/CDLF32-40	715	430	1145	260	208	104
CDLF32-50-2/CDLF32-50	890	490	1380	330	255	174
CDLF32-60-2/CDLF32-60	960	490	1450	330	255	178
CDLF32-70-2/CDLF32-70	1030	490	1520	330	255	190
CDLF32-80-2/CDLF32-80	1100	490	1590	330	255	194
CDLF32-90-2/CDLF32-90	1170	550	1720	330	255	220
CDLF32-100-2/CDLF32-100	1240	550	1790	330	255	224
CDLF32-110-2/CDLF32-110	1310	590	1900	360	255	261
CDLF32-120-2/CDLF32-120	1380	590	1970	360	285	265
CDLF32-130-2/CDLF32-130	1450	660	2110	400	310	330
CDLF32-140-2/CDLF32-140	1520	660	2180	400	310	337

Performance table

Model	Motor(kw)	Q (m <sup>3</sup> /h)	16	20	24	28	32	36	40
CDLF32-10-1	1.5	H (m)	14	13	12	11	9	7	4
CDLF32-10	2.2		18	17	15	14	13	11	8
CDLF32-20-2	3.0		29	28	26	23	20	16	11
CDLF32-20	4.0		36	34	32	29	27	23	18
CDLF32-30-2	5.5		47	44	41	38	33	28	21
CDLF32-30	5.5		54	51	48	44	40	35	27
CDLF32-40-2	7.5		65	62	58	53	46	40	30
CDLF32-40	7.5		72	69	65	59	53	47	37
CDLF32-50-2	11		83	79	74	68	60	52	41
CDLF32-50	11		90	86	81	74	67	59	47
CDLF32-60-2	11		101	97	90	83	74	65	51
CDLF32-60	11		108	104	97	90	81	72	57
CDLF32-70-2	15		119	114	107	98	88	78	60
CDLF32-70	15		126	121	113	105	95	85	67
CDLF32-80-2	15		136	131	123	11	102	90	71
CDLF32-80	15		144	138	130	120	109	97	77
CDLF32-90-2	18.5		154	148	140	129	117	102	82
CDLF32-90	18.5		162	156	147	136	124	109	88
CDLF32-100-2	18.5		175	166	157	146	131	115	91
CDLF32-100	18.5		182	173	164	152	138	122	98
CDLF32-110-2	22	193	184	173	164	146	128	102	
CDLF32-110	22	200	191	180	168	153	135	109	
CDLF32-120-2	22	211	201	189	178	160	140	113	
CDLF32-120	22	218	208	196	184	167	147	120	
CDLF32-130-2	30	230	218	206	193	174	153	124	
CDLF32-130	30	237	225	213	200	181	160	131	
CDLF32-140-2	30	247	235	222	210	189	165	135	
CDLF32-140	30	255	242	229	216	196	172	142	



Performance curve

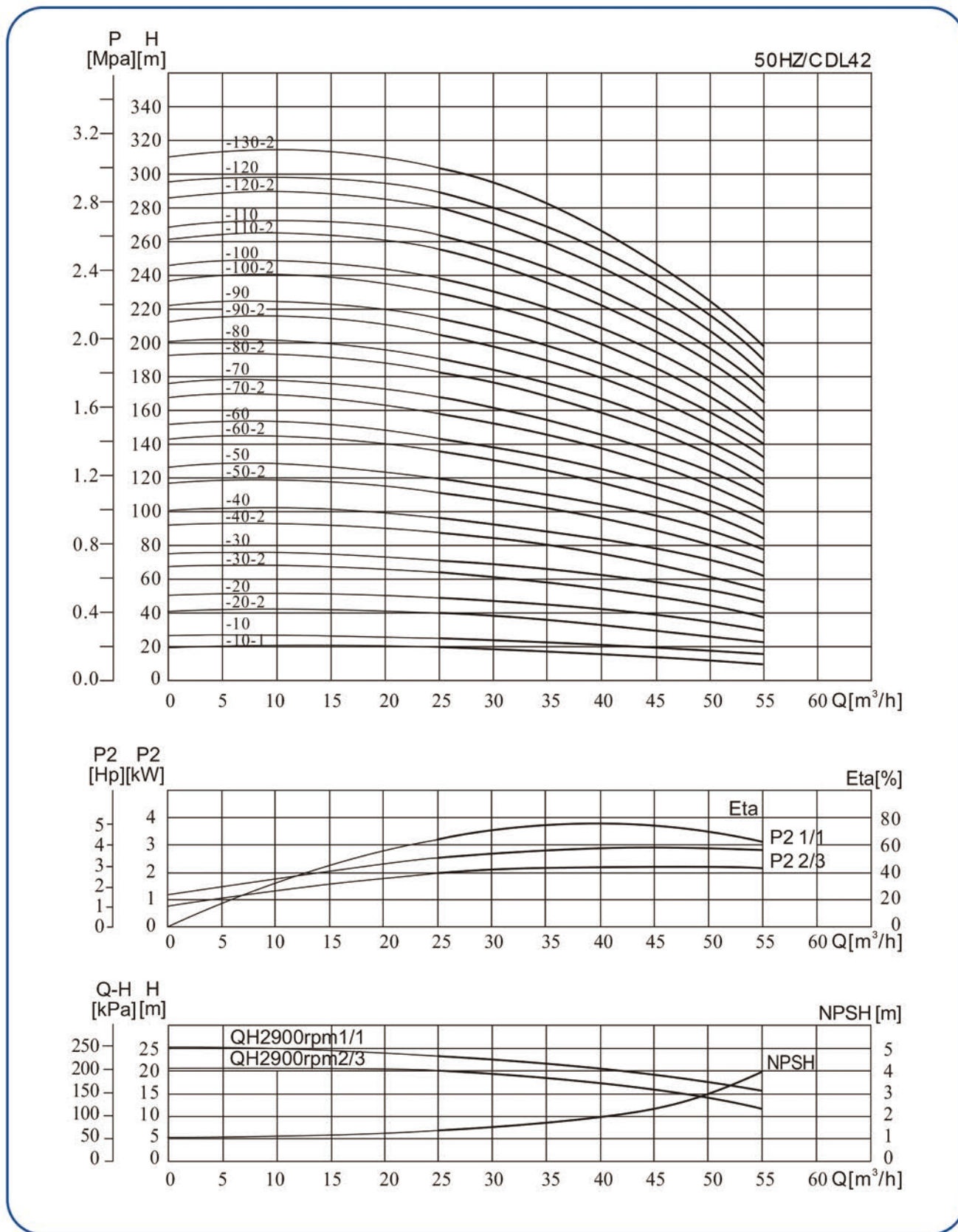

Installation sketch

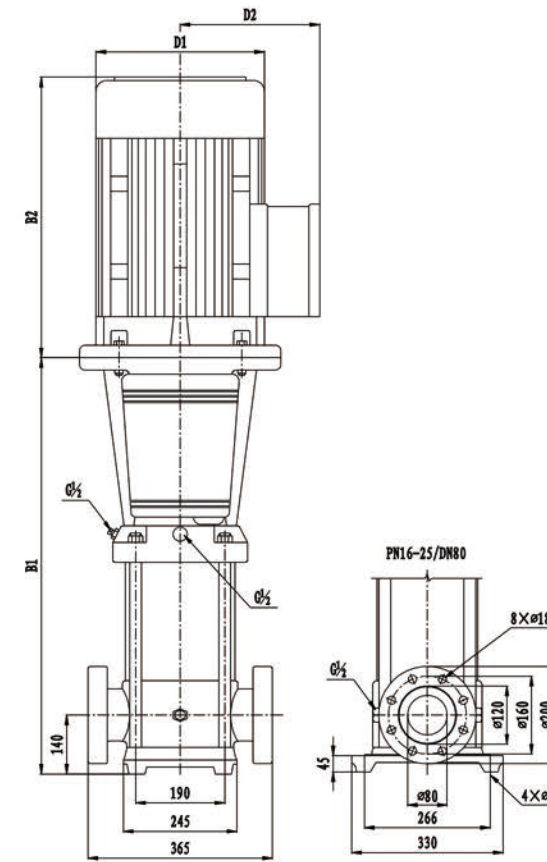

size and weight

Model	Size(mm)					Weight (kg)
	B1	B2	B1+B2	D1	D2	
CDL42-10-1	561	315/335	876/896	197/230	165/188	86/92
CDL42-10						
CDL42-20-2	641	430	1071	260	208	102/107
CDL42-20						
CDL42-30-2	826	490	1316	330	255	175
CDL42-30						
CDL42-40-2	906	490	1396	330	255	187
CDL42-40						
CDL42-50-2	986	550	1536	330	255	208
CDL42-50						
CDL42-60-2	1066	590	1656	360	285	251
CDL42-60						
CDL42-70-2	1146	660	1806	400	310	315
CDL42-70						
CDL42-80-2	1226	660	1886	400	310	319
CDL42-80						
CDL42-90-2	1306	660	1966	400	310	323/343
CDL42-90						
CDL42-100-2	1386	660	2046	400	310	347
CDL42-100						
CDL42-110-2	1466	700	2166	450	345	413
CDL42-110						
CDL42-120-2	1546	700	2246	450	345	417
CDL42-120						
CDL42-130-2	1626	700	2326	450	345	421

Performance table

Model	Motor(kw)	Q (m³/h)	25	30	35	40	42	45	50	55
CDL42-10-1	3.0	H (m)	20	19	18	17	16	15	13	11
CDL42-10	4.0		24	23	22	21	20	19	18	16
CDL42-20-2	5.5		40	38	36	33	32	30	27	23
CDL42-20	7.5		48	46	44	42	41	39	35	31
CDL42-30-2	11		63	61	58	54	52	50	44	38
CDL42-30	11		71	69	66	63	61	58	53	47
CDL42-40-2	15		87	84	80	75	73	69	62	54
CDL42-40	15		95	92	88	84	81	78	71	62
CDL42-50-2	18.5		111	107	102	96	93	88	80	69
CDL42-50	18.5		119	115	110	105	101	97	88	78
CDL42-60-2	22		135	130	124	117	113	108	97	85
CDL42-60	22		143	138	132	125	122	116	106	93
CDL42-70-2	30		158	152	146	138	134	127	115	100
CDL42-70	30		166	161	154	146	142	135	124	109
CDL42-80-2	30		182	175	168	159	154	146	133	116
CDL42-80	30		190	184	176	167	162	154	141	124
CDL42-90-2	30		205	198	190	180	174	166	150	132
CDL42-90	37		214	207	198	188	183	174	159	140
CDL42-100-2	37		230	221	212	200	194	185	168	147
CDL42-100	37		238	230	220	209	203	193	177	155
CDL42-110-2	45	255	245	236	223	217	206	188	165	
CDL42-110	45	263	255	244	232	225	214	196	173	
CDL42-120-2	45	280	270	259	245	238	226	206	181	
CDL42-120	45	289	280	268	255	247	236	216	190	
CDL42-130-2	45	305	294	282	267	259	247	225	198	



Performance curve

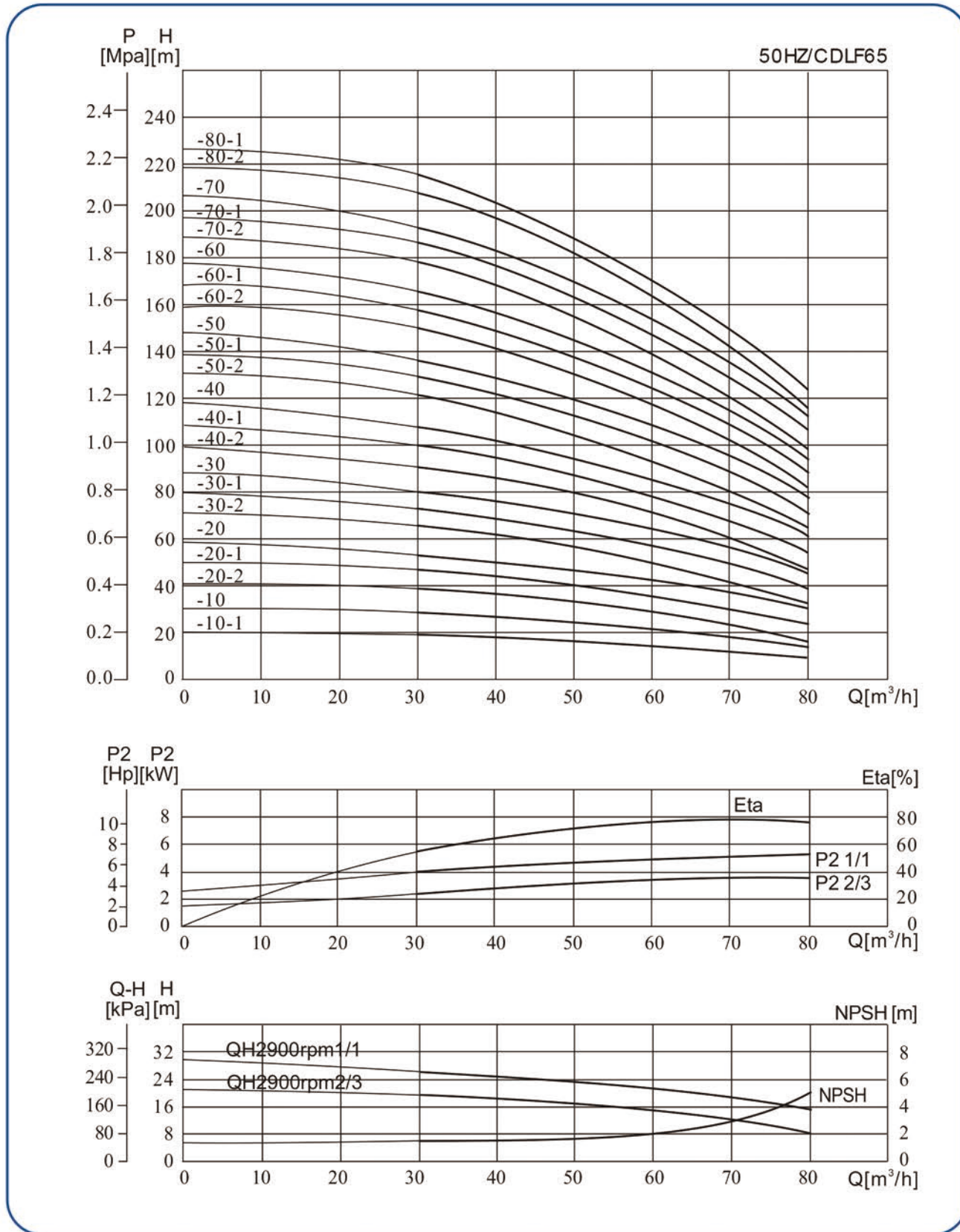

Installation sketch

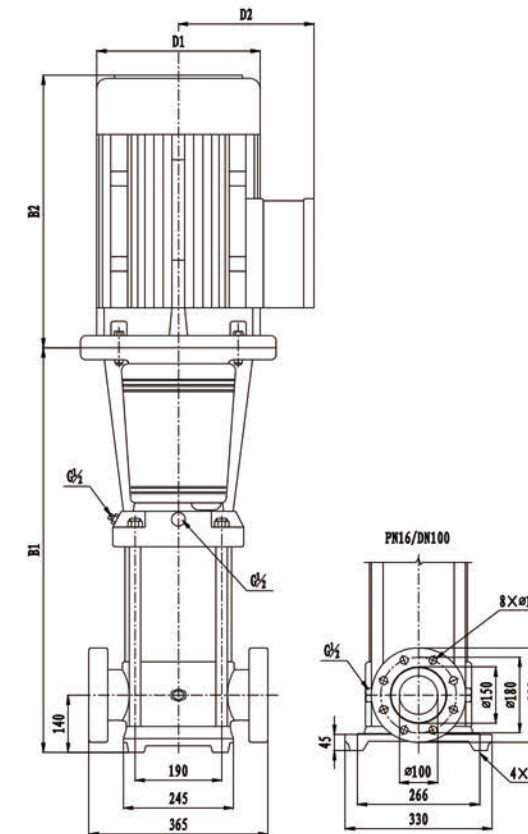

size and weight

Model	Size(mm)					Weight (kg)
	B1	B2	B1+B2	D1	D2	
CDL65-10-1	561	335	896	230	188	105
CDL65-10	561	430	991	260	208	110
CDL65-20-2	644	430	1074	260	208	120
CDL65-20-1	754	490	1244	330	255	155
CDL65-20	754	490	1244	330	255	155
CDL65-30-2	836	490	1326	330	255	195
CDL65-30-1	836	490	1326	330	255	195
CDL65-30	836	550	1386	330	255	205
CDL65-40-2	919	550	1469	330	255	208
CDL65-40-1	919	590	1509	360	285	260
CDL65-40	919	590	1509	360	285	260
CDL65-50-2	1001	660	1661	400	310	345
CDL65-50-1	1001	660	1661	400	310	345
CDL65-50	1001	660	1661	400	310	345
CDL65-60-2	1084	660	1744	400	310	350
CDL65-60-1	1084	660	1744	400	310	370
CDL65-60	1084	660	1744	400	310	370
CDL65-70-2	1166	660	1826	400	310	375
CDL65-70-1	1166	660	1826	400	310	375
CDL65-70	1166	700	1866	460	340	435
CDL65-80-2	1248	700	1948	460	340	440
CDL65-80-1	1248	700	1948	460	340	440

Performance table

Model	Motor(kw)	Q (m³/h)	30	40	50	60	65	70	80
CDL65-10-1	4.0	H (m)	19	18	16	14	13	11	8
CDL65-10	5.5		27	25	23	21	20	18	15
CDL65-20-2	7.5		39	36	33	29	26	23	17
CDL65-20-1	11		46	44	40	36	33	30	24
CDL65-20	11		53	51	47	43	40	37	30
CDL65-30-2	15		66	62	56	50	46	41	32
CDL65-30-1	15		73	69	63	57	53	48	39
CDL65-30	18.5		80	76	70	64	60	55	46
CDL65-40-2	18.5		92	87	80	71	66	60	47
CDL65-40-1	22		100	94	87	78	73	67	54
CDL65-40	22		107	101	94	85	80	74	61
CDL65-50-2	30		121	114	105	95	88	80	64
CDL65-50-1	30		128	121	112	102	95	87	71
CDL65-50	30		136	129	119	109	102	94	78
CDL65-60-2	30		150	142	131	118	110	101	81
CDL65-60-1	37		157	149	138	125	117	108	88
CDL65-60	37		164	156	145	132	124	115	95
CDL65-70-2	37		179	169	156	141	132	121	99
CDL65-70-1	37		186	176	163	148	139	128	106
CDL65-70	45		193	183	170	155	146	135	112
CDL65-80-2	45	207	196	182	164	154	142	116	
CDL65-80-1	45	215	203	189	171	161	149	123	



Performance curve

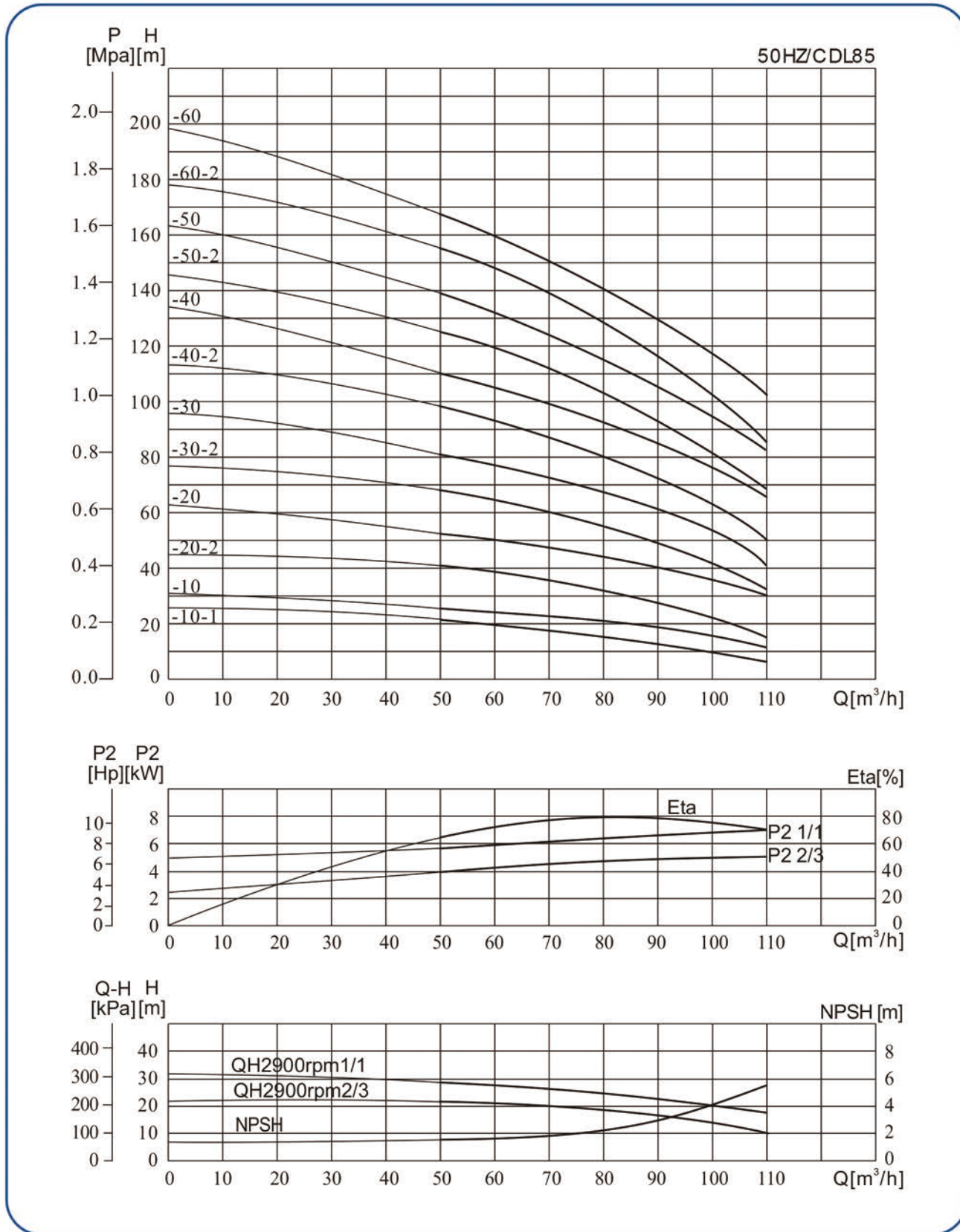

Installation sketch

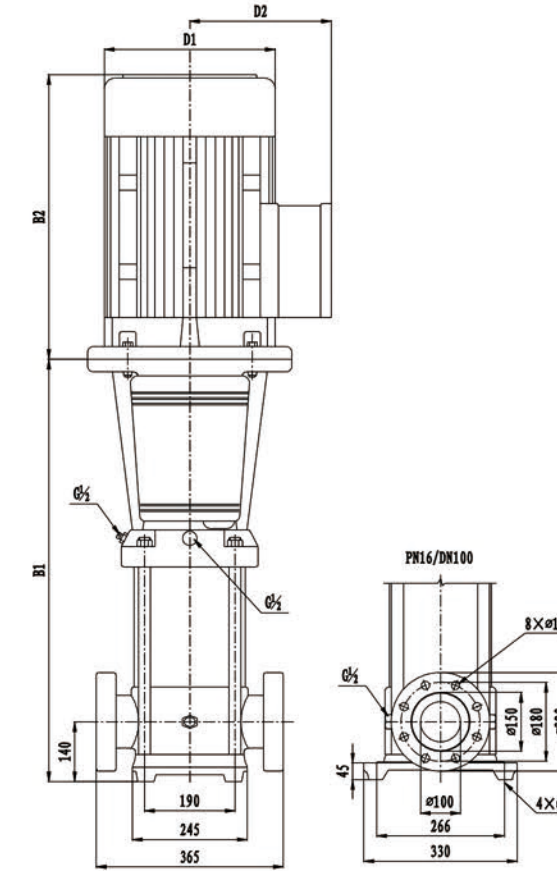

size and weight

Model	Size(mm)					Weight (kg)
	B1	B2	B1+B2	D1	D2	
CDL85-10-1	571	430	1001	260	208	120
CDL85-10	571	430	1001	260	208	122
CDL85-20-2	773	490	1263	330	255	165
CDL85-20	773	490	1263	330	255	198
CDL85-30-2	865	550	1415	330	255	212
CDL85-30	865	590	1455	360	285	265
CDL85-40-2	957	660	1617	400	310	348
CDL85-40	957	660	1617	400	310	348
CDL85-50-2	1049	660	1709	400	310	375
CDL85-50	1049	660	1709	400	310	375
CDL85-60-2	1141	700	1841	460	340	438
CDL85-60	1141	700	1841	460	340	438

Performance table

Model	Motor(kw)	Q (m³/h)	50	60	70	80	85	90	100	110
CDL85-10-1	5.5	H (m)	22	19	17	16	14	13	10	6
CDL85-10	7.5		25	24	22	21	20	19	16	12
CDL85-20-2	11		41	39	36	32	30	28	22	15
CDL85-20	15		53	50	47	44	41	40	36	30
CDL85-30-2	18.5		68	65	60	55	52	49	41	32
CDL85-30	22		81	77	72	67	64	62	55	48
CDL85-40-2	30		98	93	87	80	75	72	62	50
CDL85-40	30		110	105	100	92	86	84	76	66
CDL85-50-2	37		126	120	113	104	98	93	81	68
CDL85-50	37		139	131	124	115	110	106	94	83
CDL85-60-2	45		155	148	139	129	122	117	102	86
CDL85-60	45	168	160	150	141	134	130	117	103	



Performance curve

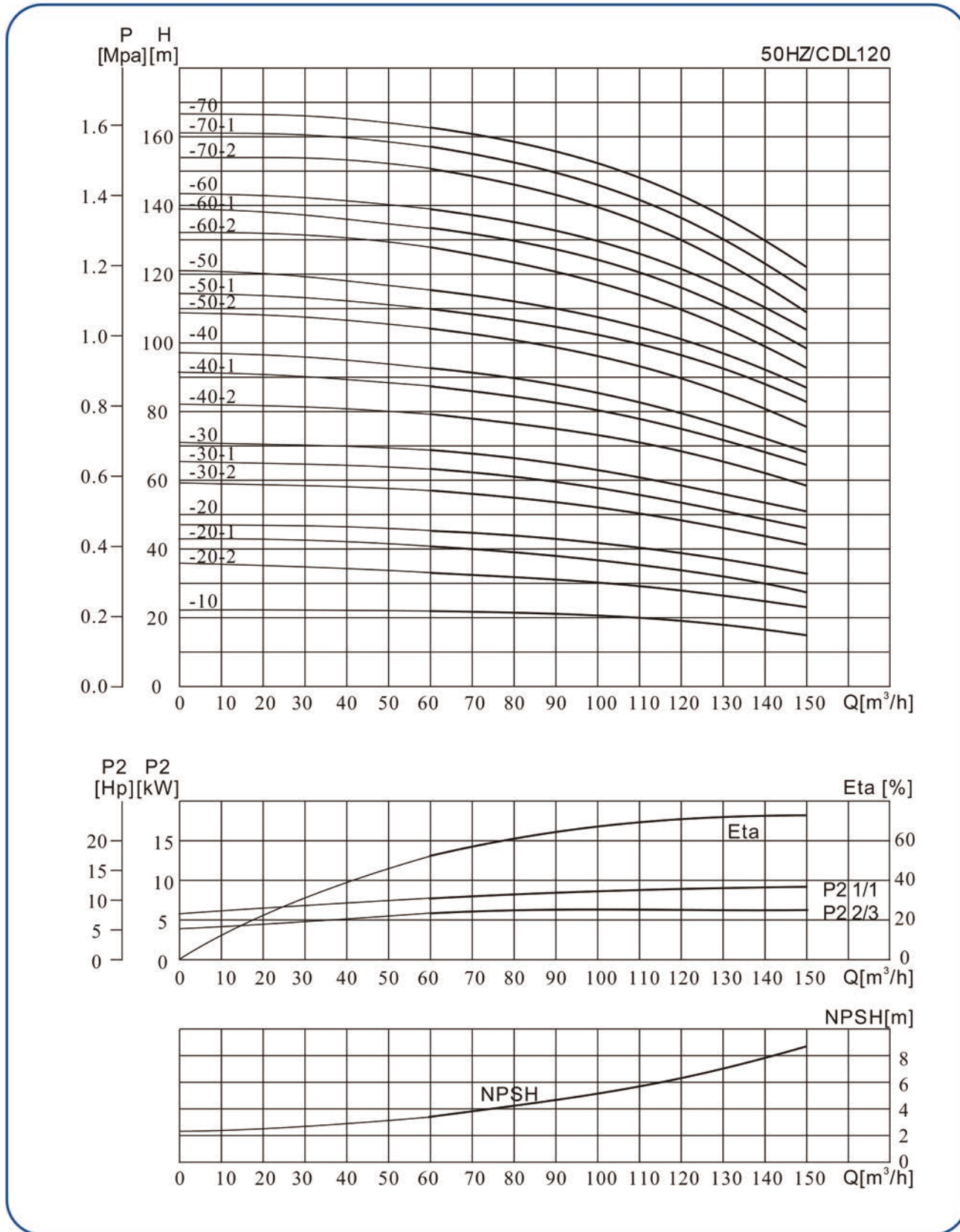

Installation sketch

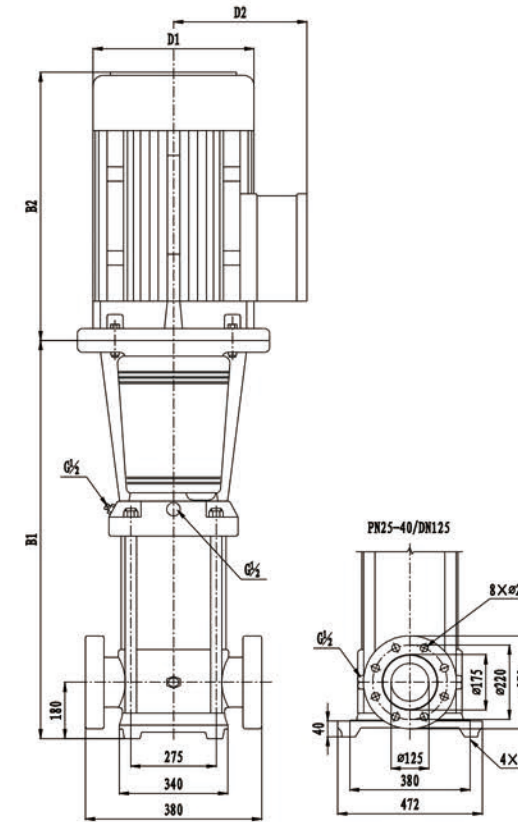

size and weight

Model	Size(mm)					Weight (kg)
	B1	B2	B1+B2	D1	D2	
CDL120-10	840	490	1330	330	255	230
CDL120-20-2	1000	490	1490	330	255	245
CDL120-20-1	1000	550	1550	330	255	250
CDL120-20	1000	590	1590	360	285	285
CDL120-30-2	1160	660	1820	400	310	360
CDL120-30-1	1160	660	1820	400	310	360
CDL120-30	1160	660	1820	400	310	360
CDL120-40-2	1320	660	1980	400	310	400
CDL120-40-1	1320	660	1980	400	310	400
CDL120-40	1320	700	2020	460	340	460
CDL120-50-2	1480	700	2180	460	340	470
CDL120-50-1	1480	700	2180	460	340	470
CDL120-50	1510	770	2280	540	370	575
CDL120-60-2	1670	770	2440	540	370	585
CDL120-60-1	1670	770	2440	540	370	585
CDL120-60	1670	845	2515	580	410	705
CDL120-70-2	1830	845	2675	580	410	715
CDL120-70-1	1830	845	2675	580	410	715
CDL120-70	1830	845	2675	580	410	715

Performance table

Model	Motor(kw)	Q (m³/h)	60	70	80	90	100	110	120	130	140	150
CDL120-10	11	H (m)	22	21.8	21.6	21	20.5	19.5	18.5	17	16	15
CDL120-20-2	15		34	33.6	33	31	30.2	30	28.5	27	25	24
CDL120-20-1	18.5		41	40	39.5	38.5	37	36.5	34.5	32.5	30	27.5
CDL120-20	22		46	45	44.5	43.5	42.4	41	40	38	36	33.5
CDL120-30-2	30		57	56	55	53.5	52	51	49	46.5	43.5	41
CDL120-30-1	30		64	63	62	60	58.5	57.5	55.5	52	49	46
CDL120-30	30		69.5	68.5	67.5	66	64.4	62.5	61	57.5	54.5	51
CDL120-40-2	37		80.5	79	78	76	73.5	72	69	66	61.5	58
CDL120-40-1	37		87	86	84.5	82	80	78	76	72	68	64.5
CDL120-40	45		92.5	91	90	88	85.5	83	81	77	73	68.5
CDL120-50-2	45		104.5	103	101	99	96	93	90	85.5	80.5	75.5
CDL120-50-1	45		110.5	109	107.5	105	102	100	97	92	86.5	83
CDL120-50	55		115.5	114	113	110	107.5	104.5	101.5	96	91	86
CDL120-60-2	55		128	125.5	123	121	117.3	113.5	110	104.5	98.5	92.5
CDL120-60-1	55		134	132	130.5	127	124	121	118	111	105	100
CDL120-60	75		139	137	135	132	128.8	126	123	116	110	104
CDL120-70-2	75	151	148	145.5	143	138.6	134	130	123.5	116.5	109	
CDL120-70-1	75	156.5	154	152	148.5	144.5	141	137.5	130	123	116.5	
CDL120-70	75	162.5	160.5	158.5	155	151	148	145	137	129	123	



Performance curve

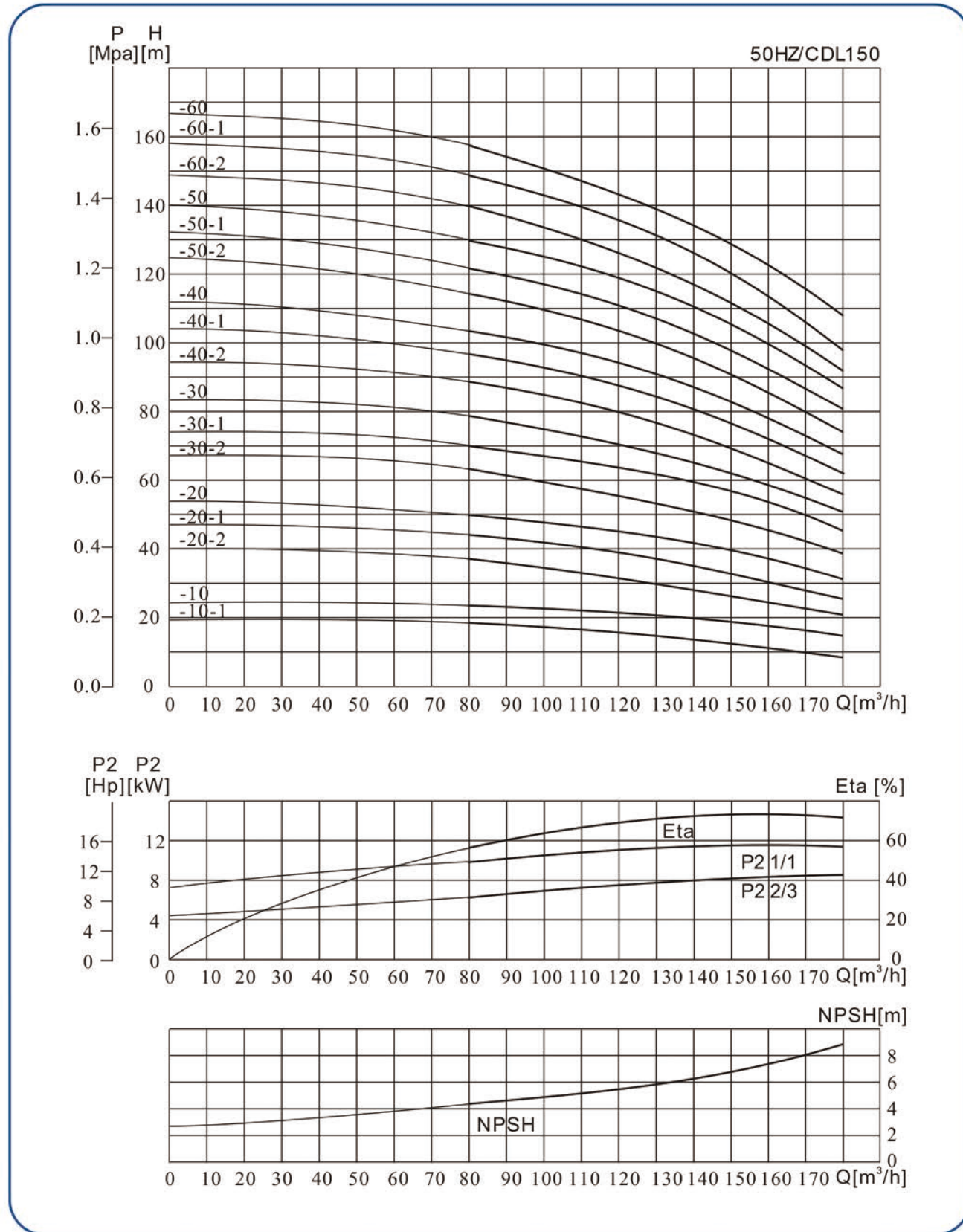

Installation sketch

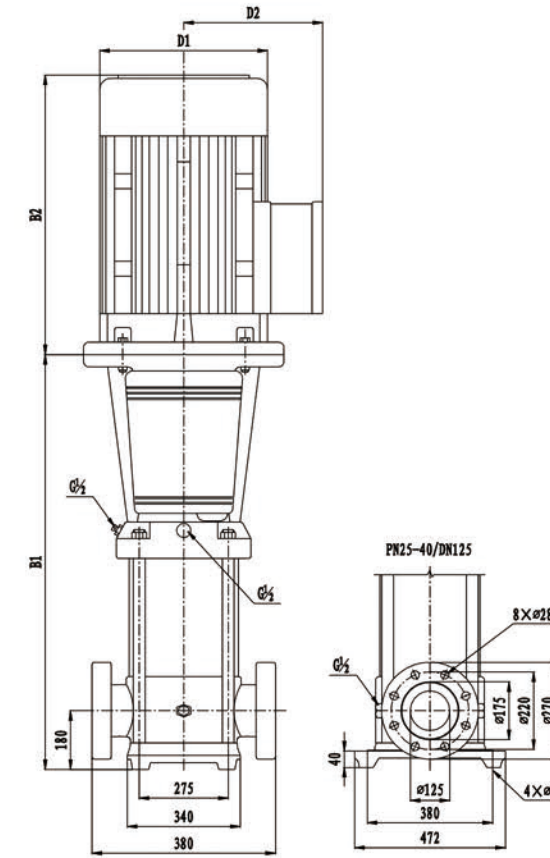

size and weight

Model	Size(mm)					Weight (kg)
	B1	B2	B1+B2	D1	D2	
CDL150-10-1	840	490	1330	330	255	230
CDL150-10	840	490	1330	330	255	235
CDL150-20-2	1000	550	1550	330	255	250
CDL150-20-1	1000	590	1590	360	285	295
CDL150-20	1000	660	1660	400	310	350
CDL150-30-2	1160	660	1820	400	310	360
CDL150-30-1	1160	660	1820	400	310	360
CDL150-30	1160	660	1820	400	310	385
CDL150-40-2	1320	700	2020	460	340	460
CDL150-40-1	1320	700	2020	460	340	460
CDL150-40	1350	770	2120	540	370	560
CDL150-50-2	1510	770	2280	540	370	570
CDL150-50-1	1510	845	2355	580	410	690
CDL150-50	1510	845	2355	580	410	690
CDL150-60-2	1670	845	2515	580	410	700
CDL150-60-1	1670	845	2515	580	410	700
CDL150-60	1670	845	2515	580	410	700

Performance table

Model	Motor(kw)	Q (m³/h)	H (m)												
			80	90	100	110	120	130	140	150	160	170	180		
CDL150-10-1	11		18.3	17.8	17.3	17	16	15	14	12.5	11	10	8.5		
CDL150-10	15		24	23	22.5	22	21.5	20.5	20	18.5	17	16	15		
CDL150-20-2	18.5		37	35.5	34	33	32	31	29	27.5	26	23	21		
CDL150-20-1	22		44.3	43	42	40	39	38.5	37.5	35	33	30	27		
CDL150-20	30		50	49	48	47	45.5	44	42	40	37	34	32		
CDL150-30-2	30		63.5	61	59	57.5	56	54.5	53	49	45.5	42	39		
CDL150-30-1	37		70	68	67	65	63	62	60	56	53	49	45		
CDL150-30	37		78	76.5	75	73	70.5	68	66	63	59	55	50.5		
CDL150-40-2	45		89	87	84	81.5	79	77	74.5	70.5	65.5	60	56		
CDL150-40-1	45		96.5	94	91.5	89	86.5	84	81.5	77	72.5	67	62		
CDL150-40	55		104	102	100	97	95	91	88	84	79.5	74	68		
CDL150-50-2	55		115.5	112	109	106	102.5	100	97	92	86	79	73.5		
CDL150-50-1	75		122.5	119.5	117	113.5	111.5	107.5	104.5	99	93.5	87	80		
CDL150-50	75		130	127.5	125	121	119	115	111.5	106.5	101	94.5	86.5		
CDL150-60-2	75		140	137	133	130	126	121	118	112	106	98	91		
CDL150-60-1	75		148.5	145	141.7	137.5	135	131	127	120.5	114.5	106.5	97.5		
CDL150-60	75		157	153	149	145	142	139.5	137	130	123.5	116	109		



