

GCLALLIANCE ELECTRONICS CO. , LTD

SPECIFICATION FOR APPROVAL

**RoHS
Compliant**

CUSTOMER :

CUSTOMER'S P/N:

EP-13SMD

GCL P/N:

12000972

DESCRIPTION:

Transformers

EDITION:

A

PREPARED BY	CHECKED BY	APPROVED BY
JOE	TOM	BOB

CUSTOMER APPROVE

GCLALLIANCE ELECTRONICS CO., LTD

SPECIFICATION FOR APPROVAL

**RoHS
Compliant**

CUSTOMER:	
CUSTOMER'S P/N:	EP-13SMD
GCL P/N:	12000972
DESCRIPTION:	Transformers

RECORDS			
DATE	EDITION	DESCRIPTION	EXECUTOR
2023/9/6	A	Initial release	

--	--	--

APPROVAL SIGNATURE		
PREPARED BY	CHECKED BY	APPROVED BY
JOE	TOM	BOB

GCLALLIANCE ELECTRONICS CO., LTD

SPECIFICATION FOR APPROVAL

RoHS
Compliant

1、 DIMENSIONS: (UNIT:mm)

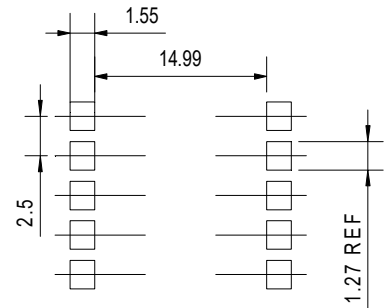
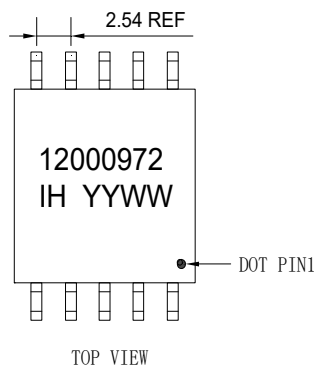
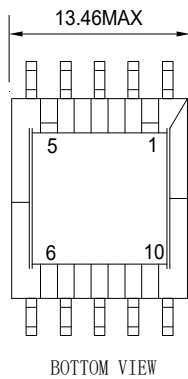
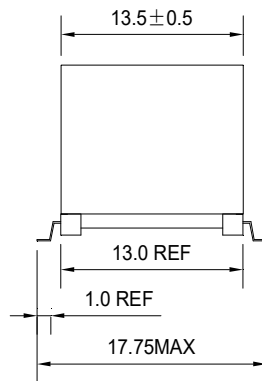
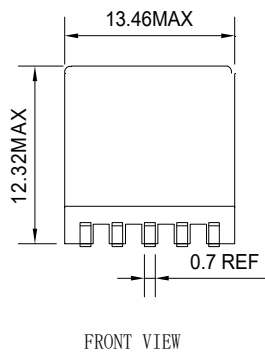

Terminal Dimensions
Customer determine PCB pad dimensions

NOTE:

1. Pin6-10 side of bobbin towards to machine with clockwise winding;
2. Marking on the top of core, place a white dot on the top of pin1 ;
3. Securing cores with tape ;

PREPARED BY	CHECKED BY	APPROVED BY	CUSTOMER'S P/N:	EP-13SMD
JOE	TOM	BOB	GCL P/N:	12000972
			EDITION:	A
			DATE:	2023/9/6

GCLALLIANCE ELECTRONICS CO., LTD
SPECIFICATION FOR APPROVAL

**RoHS
Compliant**

2、 SCHEMATIC:

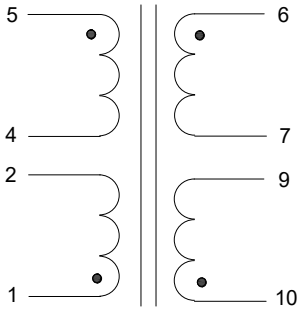

3、 CONSTRUCTIONS:

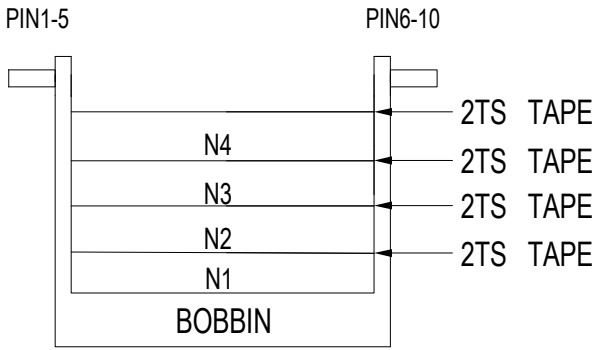

4、 ELECTRICAL CHARACTERISTICS:

- 4.1 INDUCTANCE (100KHz, 0.1V) : L (5-4) : 20uH ±10%
- 4.2 LEAKAGE INDUCTANCE: LK (5-4) 1.0uH MAX (100KHZ/0.1V) (SHORT OTHERS)
- 4.3 DC RESISTANCE: DCR (5-4) : 150mΩ MAX DCR (10-9) : 60mΩ MAX
DCR (6-7) : 250mΩ MAX DCR (1-2) : 150mΩ MAX
- 4.4 TRANSFORMER RATIO (10KHz 0.1V)
5-4 to 10-9 : 28:12±2% 5-4to6-7: 28:24±2%
5-4to1-2: 28:10±2%
- 4.5 HI-POT: PRI to SEC: AC 60HZ 1.5KV/1mA/1S

PREPARED BY	CHECKED BY	APPROVED BY	CUSTOMER'S P/N:	EP-13SMD
JOE	TOM	BOB	GCL P/N:	12000972
			EDITION:	A
			DATE:	2023/9/6

GCLALLIANCE ELECTRONICS CO., LTD

SPECIFICATION FOR APPROVAL

**RoHS
Compliant**

5. MATERIAL LIST:

NO	ITEM	MATERIAL	MANUFACTURER	UL MARK
1	INSULATION SYSTEM	OBJY2/IH-130-1 OBJS2/DJ-T130-1A	GCLALLIANCE ELECTRONICS CO LTD DAH JIN TECHNOLOGY CO LTD	E359898 E318181
2	BOBBIN	PM9630	SUMITOMO CHEMICAL CO., LTD	E41429
3	CORE	DMR95	HENGDIAN GROUP DMEGC MAGNETICS CO., LTD.	N/A
4	WIRE	2UEW-H	PACIFIC ELECTRIC WIRE & CABLE (SHENZHEN) CO LTD DONG GUAN YIDA INDUSTRIAL CO., LTD	E201757 E344055
6	TAPE	92# PF* (d) (g)	3M COMPANY JINGJIANG YAHUA PRESSURE SENSITIVE GLUE CO LTD	E17385 E165111
7	GLUE	E-500HF OR EQU	DONGGUAN EATTO ELECTRONIC MATERIAL CO LTD	E218090