

Main Line Filter

Ordering Code

SF	-	AFF	-	350	-	N04	-	D
Company Name		Series		Body Size 350:NPT1/2" 550:NPT1" 650:NPT1 1/2"		Thread Pipe 04:NPT1/2" 10:NPT1" 14:NPT1 1/2"		Drain Ttype D: Auto Drain



Overall Dimension

Graphic Symbol

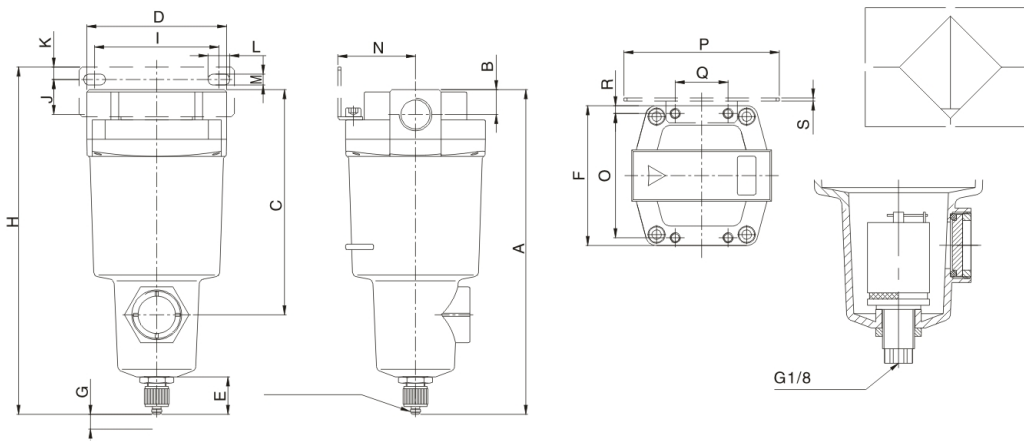

Model	Thread Pipe	A	B	C	D	E	F	G	mm(inch)											
									H	I	J	K	L	M	N	O	P	Q	R	S
AFF350	NPT1 /2	209 (8.228)	16 (0.629)	145 (5.708)	90 (3.543)	24 (0.944)	90 (3.543)	10 (0.393)	224 (8.818)	80 (3.149)	23 (0.905)	8 (0.314)	14 (0.551)	7 (0.275)	50 (1.968)	80 (0.314)	97 (3.818)	34 (1.338)	5 (0.196)	2.3 (0.090)
AFF550	NPT1	265 (10.433)	22 (0.866)	200 (7.874)	122 (4.803)	24 (0.944)	122 (4.803)	10 (0.393)	283 (11.141)	100 (3.937)	30 (1.181)	10 (0.393)	16 (0.629)	9 (0.354)	65 (2.559)	102 (4.015)	126 (4.160)	60 (2.362)	10 (0.393)	3.2 (0.125)
AFF650	NPT1-1/2	315 (12.401)	32 (1.259)	253 (9.960)	160 (6.299)	24 (0.944)	160 (6.299)	10 (0.393)	336 (13.228)	150 (5.905)	38 (1.496)	15 (0.590)	20 (0.787)	11 (0.433)	85 (3.346)	136 (5.354)	180 (7.08)	76 (3.992)	12 (0.472)	4.5 (0.177)

Specification

Model	SFAFF350-N04	SFAFF550-10	SFAFF650-14
Thread Pipe	NPT1/2"	NPT1"	NPT1/2"
Rating Flow(L/min)	1500	3700	6000
Max. Working Pressure	1.0MPA, 145PSI		
Min. Working Pressure	0.05MPA, 7Psi		
Operating Temperature	(Not Frozen)(22~140 F)		
Filter Precision	3um(Removal95%)		
Element Life	(At Press.Differential)(14.5Psi)		