

HSF

RoHS

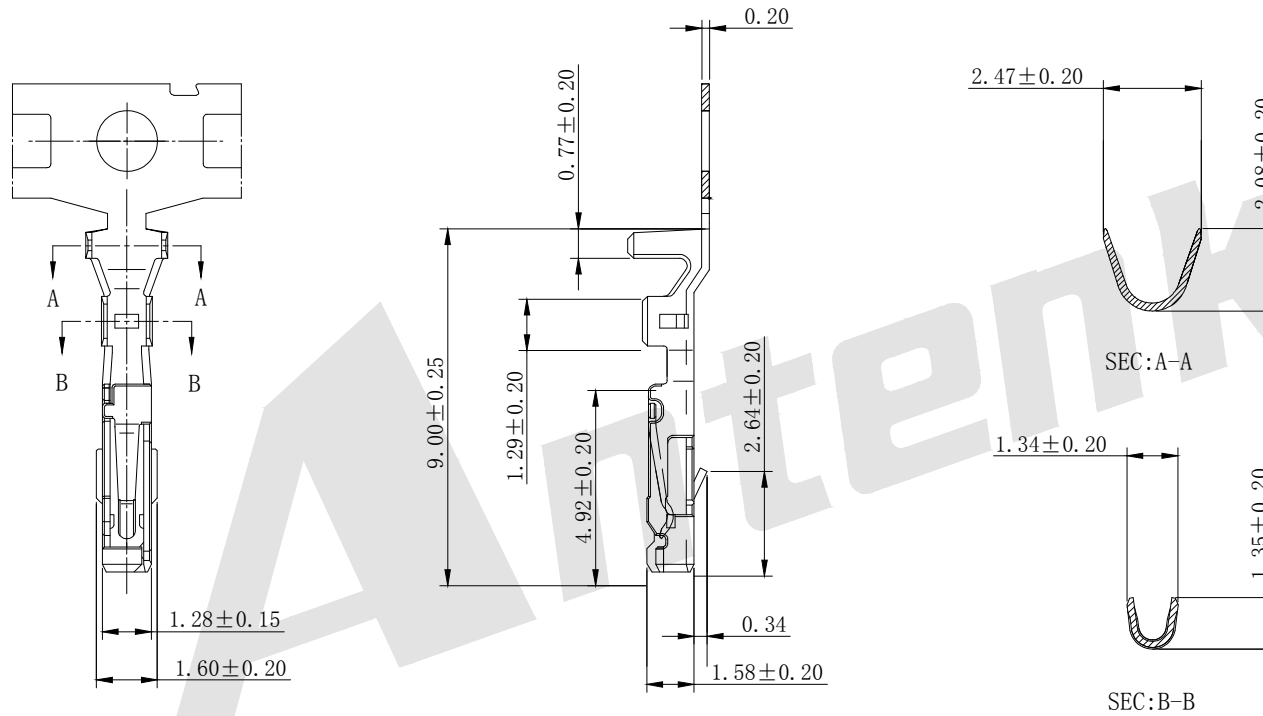

Ordering Information & Dimensions:

Unit:mm

Part No	Wire Range	Insultion O.D.	Material	Finish	Qty/Reel
ATL2009-T	AWG#26-#28	1.40mm(max)	Phosphor Bronze	Tin Over Nickel	10,000PCS
ATL2009-G	AWG#26-#28	1.40mm(max)	Phosphor Bronze	Gold Over Nickel	10,000PCS

Unless Otherwise specified tolerance  
 X. ±0.35 X.XX: ±0.20  
 X.X: ±0.25 X.XXX: ±0.15

**Antenk**

ANTENK ELECTRONICS CO.,LTD  
[Http://www.antenk.com](http://www.antenk.com)  
 E-mail:sales@antenk.com

SCALE: As Shown UNIT: mm

DRAW Wu Feng Rong DATE 05/12/2021

CHECK Bob Yang DATE 05/12/2021

TITLE:  
2.00mm Pitch Crimp Terminal

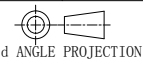

DRAWING NO: ATL2009

PRODUCT NO: ATL2009

REV	DESCRIPTION	DATE