

HSF

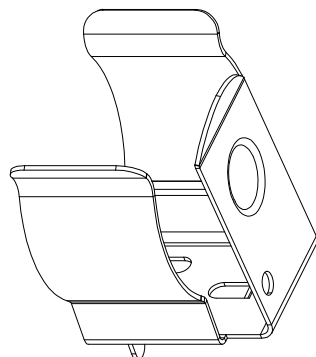

ROHS

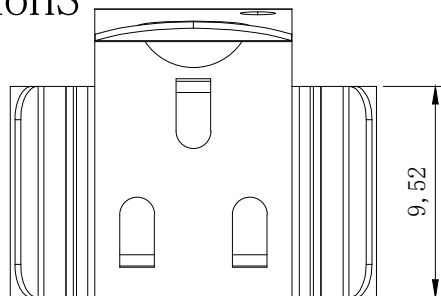

NOTES:

- 1. MATERIAL: ANNEALED SPRING STEEL, T=0.3mm.
- 2. PLATING:
80U" Min TIN PLATED OVERALL
50U" Min NICKEL PLATED UNDER OVERALL
- 3. THIS PRODUCT IS SUITABLE FOR 16-19MM BATTERY

Order code:

BS - S - SN - B - 54
 ① ② ③ ④ ⑤

- ① BS: Battery Contacts
- ② Appearance for the product
S:180 TYPE
- ③ Contact Plating
SI:NICKEL PLATE
SN: Tin
G0: Gold flash
G1: 3u" Gold
G2: 5u" Gold
G3: 10u" Gold
G4: 15u" Gold
G5: 30u" Gold
- ④ Packing method
A: Tray packing
R: Tape & reel packing
B: Bag packing
- ⑤ Product number
54:54 STYLE

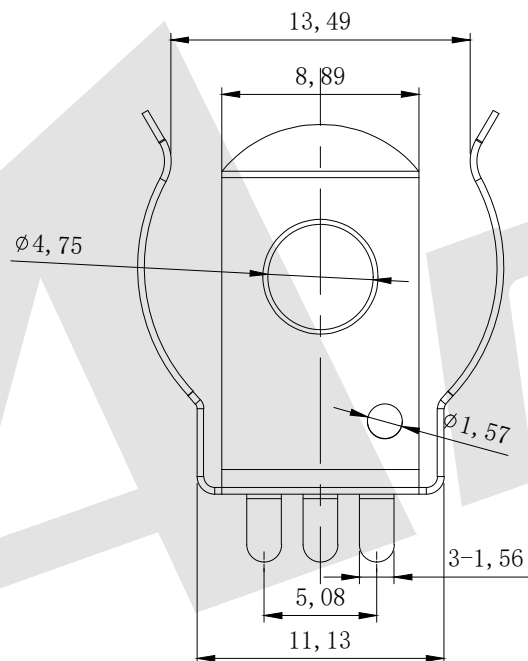

MOUNTING LAYOUT

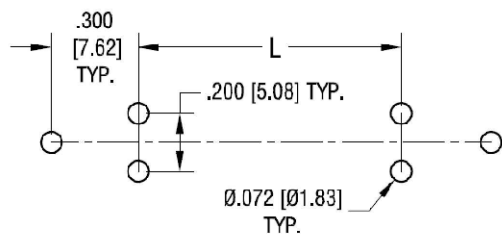
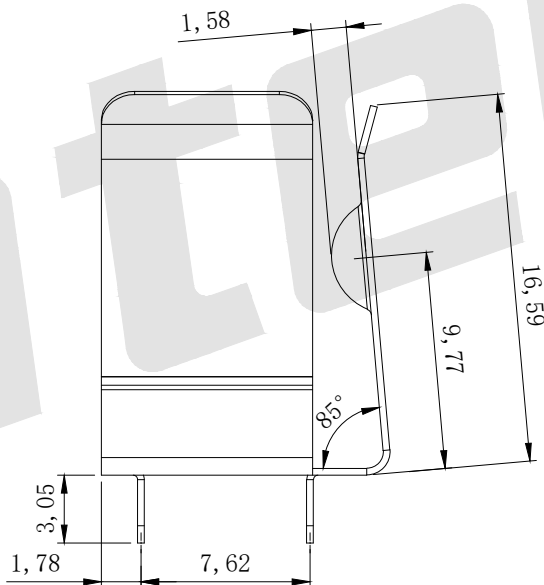

CELL SIZE	"L" DIMENSION
18650 *	1.890 [48.00]
CR123A	.570 [14.50]
17500	1.218 [30.90]

* FOR BATTERIES WITH BUILT-IN CIRCUIT PROTECTION

Unless Otherwise specified tolerance
 X. ±0.50 X.XX: ±0.25
 X.X: ±0.35 X.XXX: ±0.10



ANTENK ELECTRONICS CO., LTD
[Http://www.antenk.com](http://www.antenk.com)
 E-mail:sales@antenk.com

SCALE: As Shown	UNIT: mm
DRAW Wu Feng Rong	DATE 28/08/2020
CHECK BobYang	DATE 28/08/2020

TITLE:
Battery Holder 54 STYLE FOR 16-19MM BATTERY

DRAWING NO: BS-S-SN-B-54
 PRODUCT NO: BS-S-SN-B-54

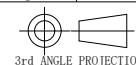

REV	DESCRIPTION	DATE