

HSF

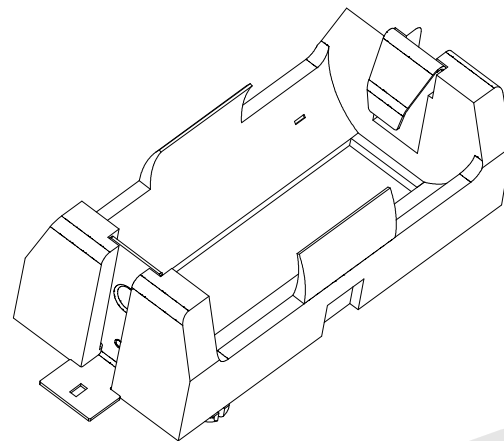
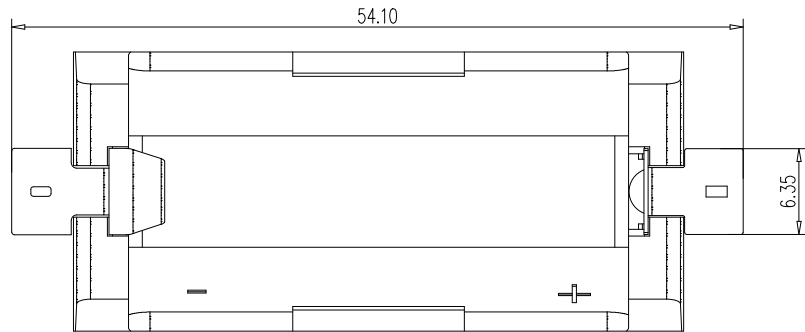

Material:
Base: PA46+30%GF, BLACK, UL94V-0;
CONTACT: 0.3MM THK STAINLESS STEEL
FINISH: BRIGHT TIN 200U" OVER NICKEL 50U"

BBC - M - SN - A - 096P

① ② ③ ④ ⑤

① BBC: Battery Holder 电池盒
② Apperance for the product 连接形式

M: SMT

③ Contact Plating 端子电镀
S1: Tin NICKEL Plated 锡镍合金 G2: 5U" Gold 金
SN: Tin 锡 G3: 10U" Gold 金
G0: Gold flash 普金 G4: 15U" Gold 金
G1: 3U" Gold 金 G5: 30U" Gold 金

④ Packing method 包装方式
A: Tray packing 吸塑盒装
B: BAG 袋装
⑤ Product number 产品编号
096P

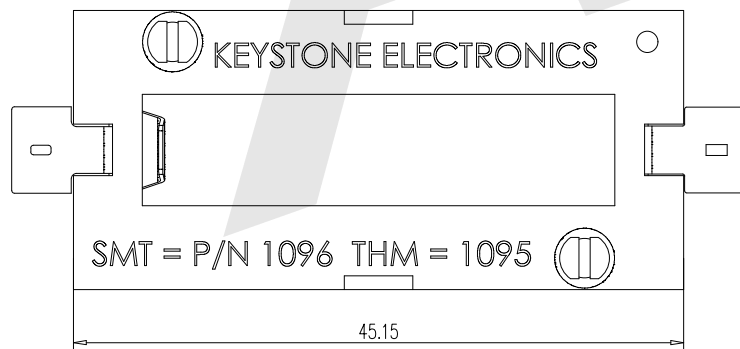
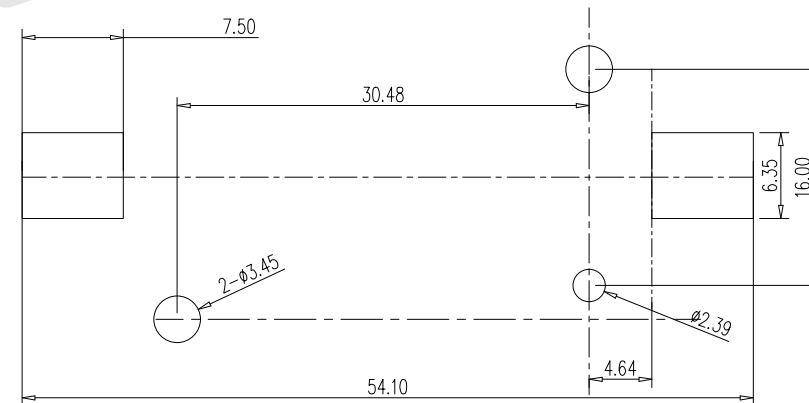
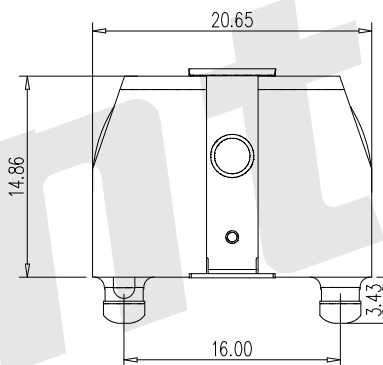
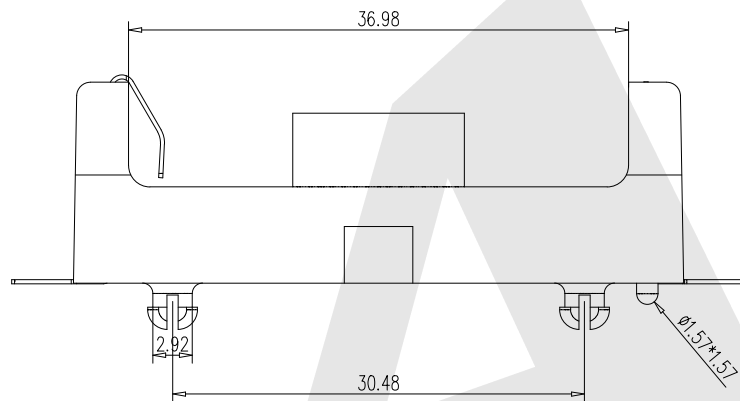

Unless Otherwise specified tolerance
X. \pm 0.35 X.XX: \pm 0.20
X.X: \pm 0.25 X.XXX: \pm 0.15

SCALE: As Shown UNIT: mm
DRAW YH DATE 1/2/2024
CHECK BobYang DATE 1/2/2024
VER./版本号



Antenk® ANTENK ELECTRONICS CO., LTD
Http://www.antenk.com
E-mail:sales@antenk.com

TITLE: Single Battery Holder For 18350 SMT

DRAWING NO: BBC-M-SN-A-096P
PRODUCT NO: BBC-M-SN-A-096P

MK/标记

DESCRIPTION/修订内容

DATE/日期(M/D/Y)