

HSF



ROHS

Material:
 Base: PA46+30%GF, BLACK, UL94V-0;
 CONTACT: 0.3MM THK STAINLESS STEEL
 FINISH: BRIGHT TIN 200U" OVER NICKEL 50U"

BBC - M - SN - A - 098

- ① BBC: Battery Holder 电池盒
- ② Apperance for the product 连接形式
- M: SMT
- ③ Contact Plating 端子电镀
 - SI: Tin NICKEL Plated 锡镍合金 G2: 5U" Gold 金
 - SN: Tin 锡 G3: 10U" Gold 金
 - GO: Gold flash 普金 G4: 15U" Gold 金
 - G1: 3U" Gold 金 G5: 30U" Gold 金
- ④ Packing method 包装方式
 - A: Tray packing 吸塑盒装
 - B: BAG 袋装
- ⑤ Product number 产品编号
098

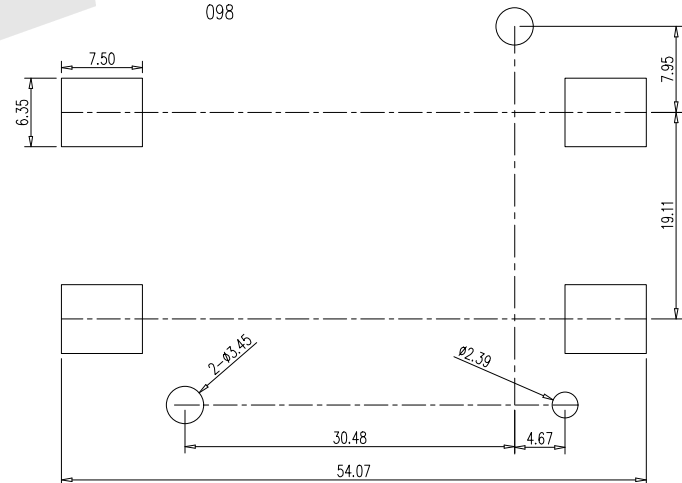
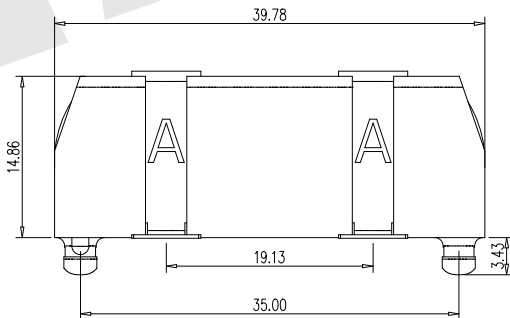
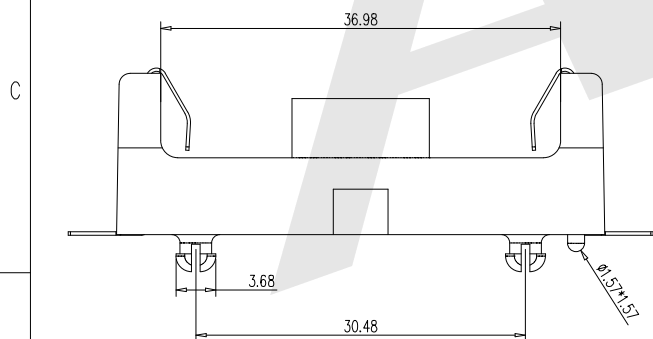
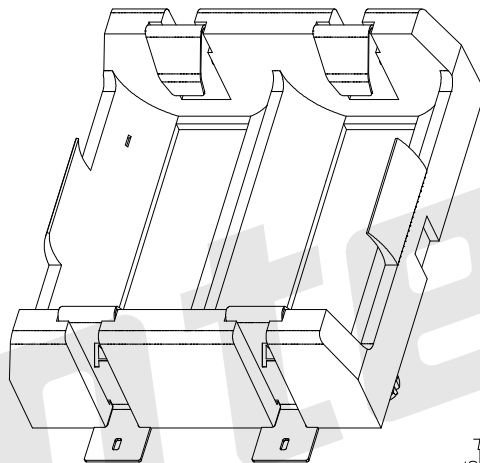
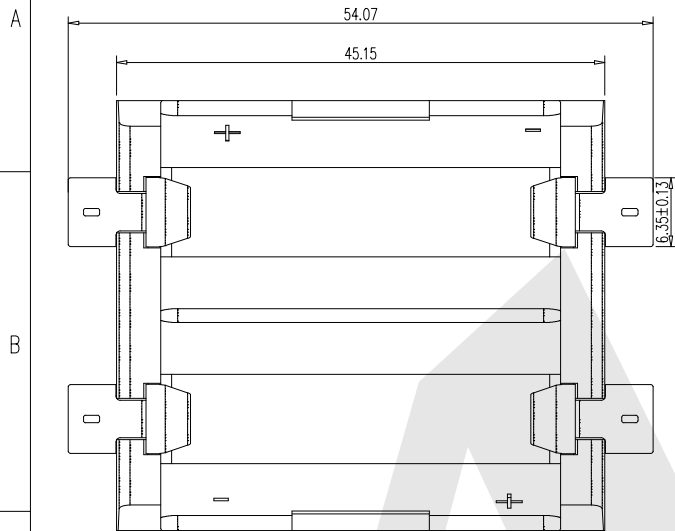

Unless Otherwise specified tolerance
 X.±0.35 X.XX: ±0.20
 X.X: ±0.25 X.XXX: ±0.15

Antenk® ANTENK ELECTRONICS CO., LTD
 Http://www.antenk.com
 E-mail:sales@antenk.com

SCALE: As Shown UNIT: mm

TITLE: Dual Battery Holder For 18350 SMT

DRAW YH DATE 01/03/2024

CHECK BobYang DATE 01/03/2024

DRAWING NO: BBC-M-SN-A-098

PRODUCT NO: BBC-M-SN-A-098

VER./版本号 3rd ANGLE PROJECTION

MK/标记	DESCRIPTION/修订内容	DATE/日期(M/D/Y)
1		
2		
3		
4		
5		