

HSF

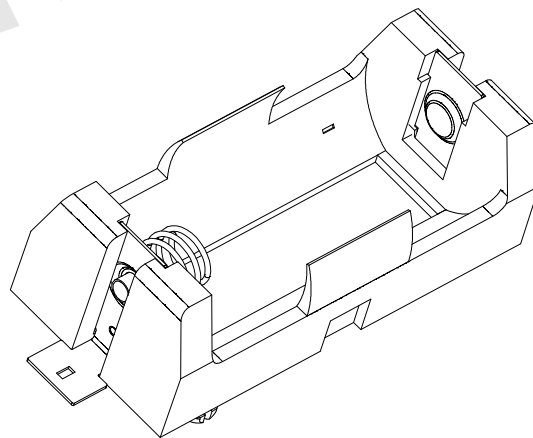

ROHS

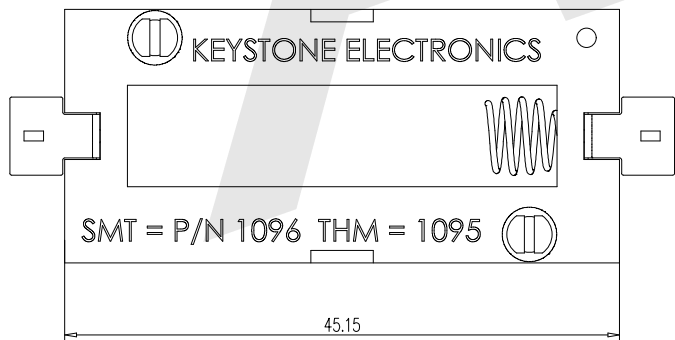
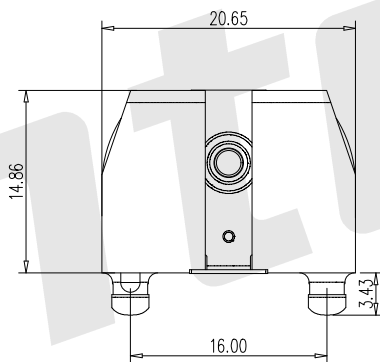
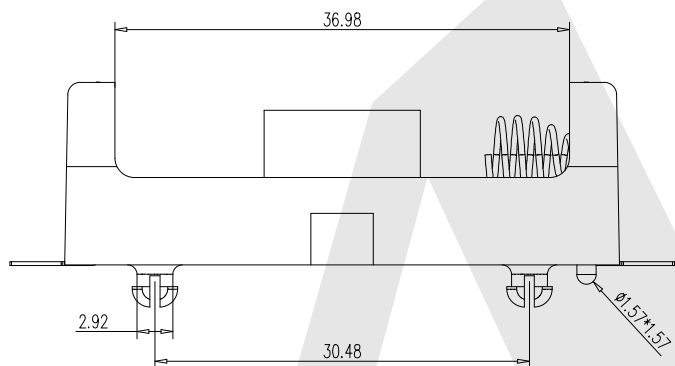
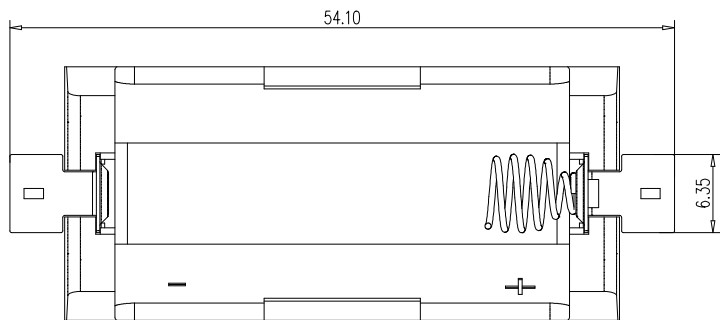

Material:
Base: PA46+30%GF, BLACK, UL94V-0;
CONTACT: 0.3MM THK STAINLESS STEEL
FINISH: BRIGHT TIN 200U" OVER NICKEL 50U"

BBC - M - SN - A - 110

① ② ③ ④ ⑤

① BBC: Battery Holder 电池盒
② Apperance for the product 连接形式

M: SMT

③ Contact Plating 端子电镀
SI: Tin NICKEL Plated 锡镍合金 G2: 5U" Gold 金
SN: Tin 锡 G3: 10U" Gold 金
GO: Gold flash 普金 G4: 15U" Gold 金
G1: 3U" Gold 金 G5: 30U" Gold 金

④ Packing method 包装方式
A: Tray packing 吸塑盒装
B: BAG 袋装

⑤ Product number 产品编号
110

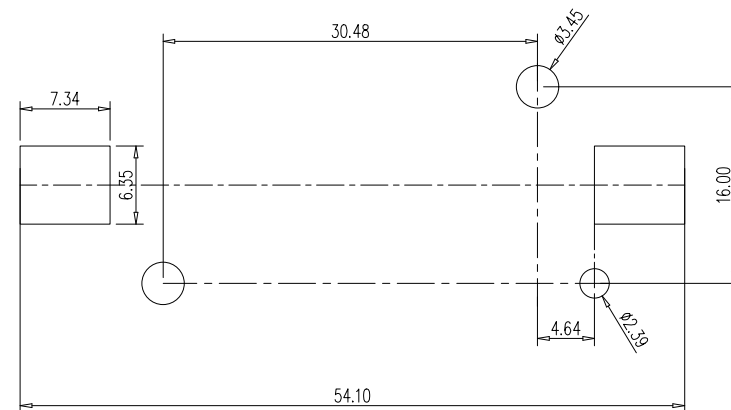

Unless Otherwise specified tolerance
X.±0.35 X.XX:±0.20
X.X:±0.25 X.XXX:±0.15

SCALE: As Shown UNIT: mm
DRAW YH DATE 01/04/2024
CHECK BobYang DATE 01/04/2024

VER./版本号 3rd ANGLE PROJECTION

Antenk® ANTENK ELECTRONICS CO., LTD
Http://www.antenk.com
E-mail:sales@antenk.com

TITLE: Single Battery Holder For 18350 SMT

DRAWING NO: BBC-M-SN-A-110
PRODUCT NO: BBC-M-SN-A-110

MK/标记	DESCRIPTION/修订内容	DATE/日期(M/D/Y)	6	7	8
-------	------------------	----------------	---	---	---