

HSF

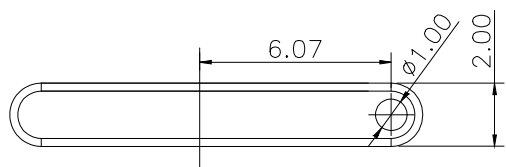

ROHS

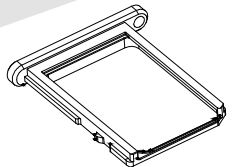
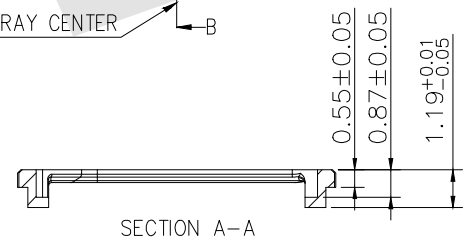
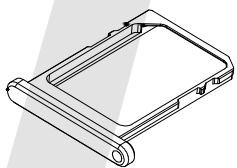
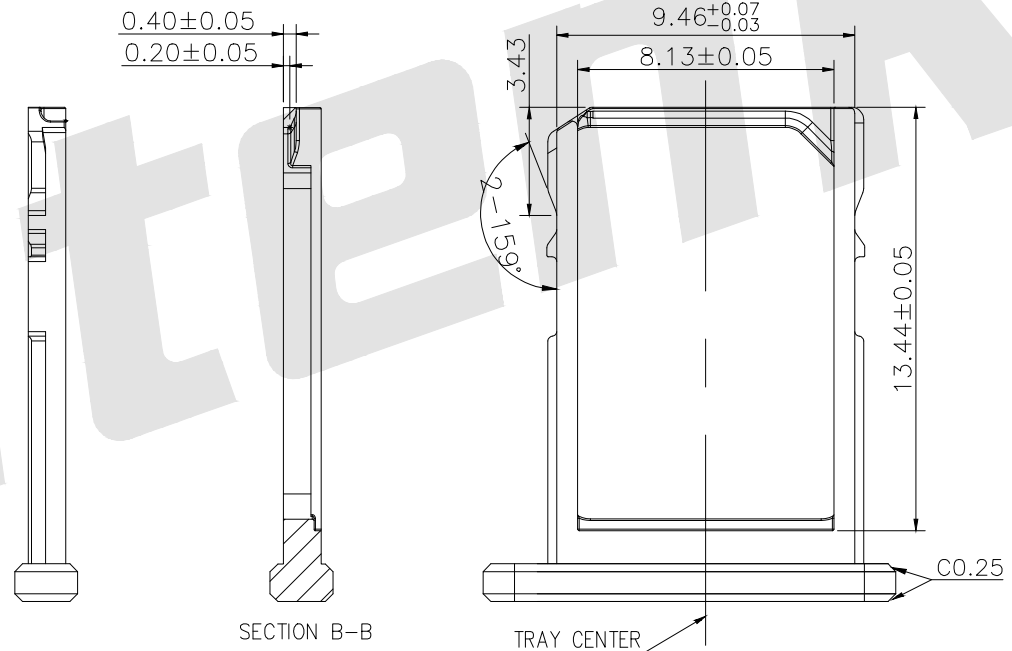
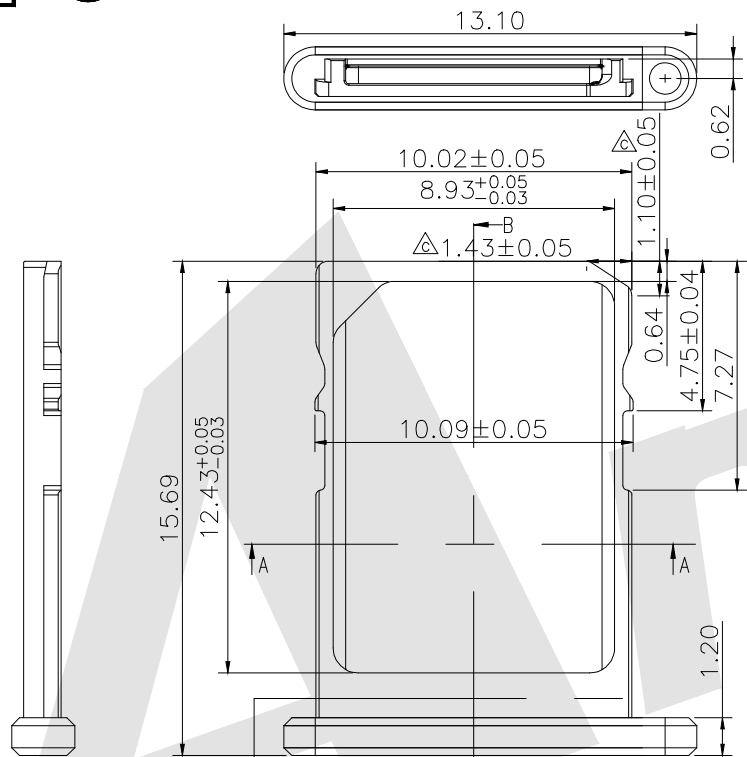

NOTES:

1. Material:NO.3, Zine Alloy (Zamak3)
2. Rprocess:Die Casting Molding, SIM Contact Local Insulation Treatment
3. Appearance:Product The Week Without Burr, Appearance No Scratch And Indentation, The Oil Bad Distortion, Cracke, Deformation, etc.

Unless Otherwise specified tolerance
 X. ±0.35 X.XX: ±0.20
 X.X: ±0.25 X.XXX: ±0.15

Antenk® ANTENK ELECTRONICS CO., LTD
[Http://www.antenk.com](http://www.antenk.com)
 E-mail:sales@antenk.com

SCALE: As Shown	UNIT: mm
DRAW Wu Feng Rong	DATE 05/03/2021
CHECK BobYang	DATE 05/03/2021

TITLE:
NANO SIM Tray With Hole Bright Nickel

DRAWING NO: ATK-NSIMT001

PRODUCT NO: ATK-NSIMT001



REV	DESCRIPTION	DATE
1		
2		
3		
4		
5		