

HSF



ROHS

Material:  
Base: PA46+30%GF, BLACK, UL94V-0;  
CONTACT: 0.3MM THK STAINLESS STEEL  
FINISH: BRIGHT TIN 200U" OVER NICKEL 50U"

BBC - M - SN - A - 098P

- ① BBC: Battery Holder 电池盒
- ② Apperance for the product 连接形式

- M: SMT
- ③ Contact Plating 端子电镀
  - SI: Tin NICKEL Plated 锡镍合金 G2: 5U" Gold 金
  - SN: Tin 锡 G3: 10U" Gold 金
  - GO: Gold flash 普金 G4: 15U" Gold 金
  - G1: 3U" Gold 金 G5: 30U" Gold 金

- ④ Packing method 包装方式
  - A: Tray packing 吸塑盒装
  - B: BAG 袋装
- ⑤ Product number 产品编号  
098P

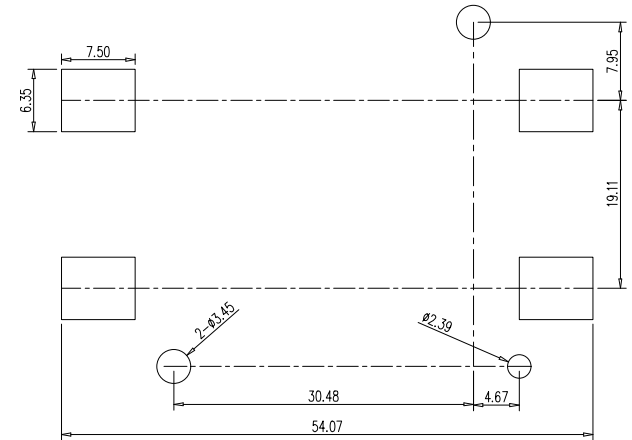
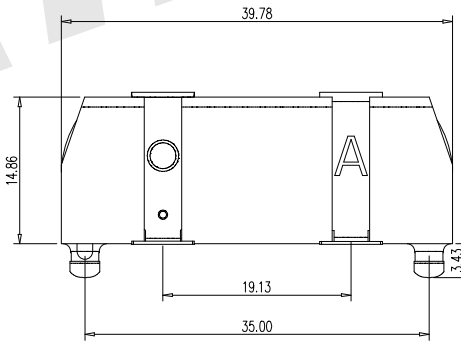
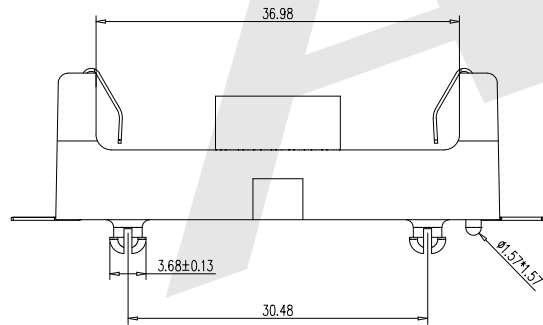
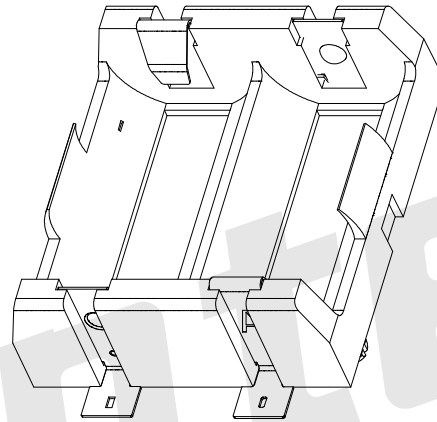
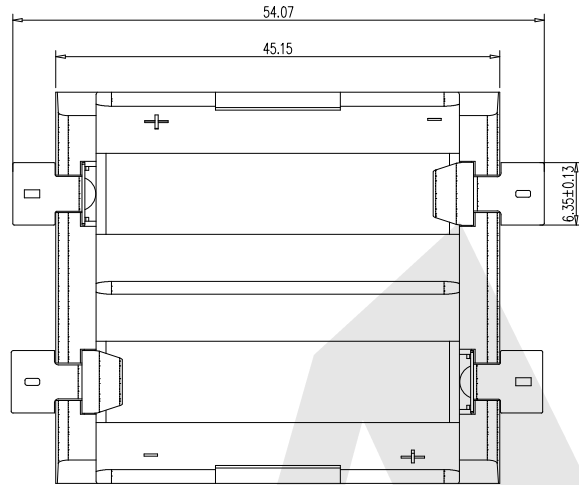

Unless Otherwise specified tolerance  
 X.±0.35 X.XX: ±0.20  
 X.X: ±0.25 X.XXX: ±0.15

SCALE: As Shown UNIT: mm

DRAW YH DATE 01/03/2024

CHECK BobYang DATE 01/03/2024

VER./版本号

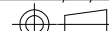

3rd ANGLE PROJECTION

**Antenk**® ANTENK ELECTRONICS CO., LTD  
 Http://www.antenk.com  
 E-mail:sales@antenk.com

TITLE: Dual Battery Holder For 18350 SMT

DRAWING NO: BBC-M-SN-A-098P

PRODUCT NO: BBC-M-SN-A-098P

MK/标记

DESCRIPTION/修订内容

DATE/日期(M/D/Y)

1

2

3

4

5

6

7

8