

HSF

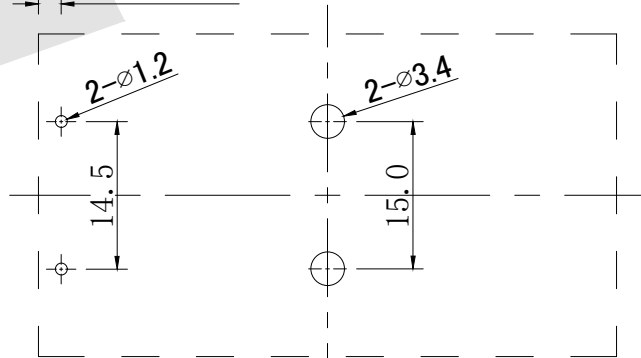

ROHS

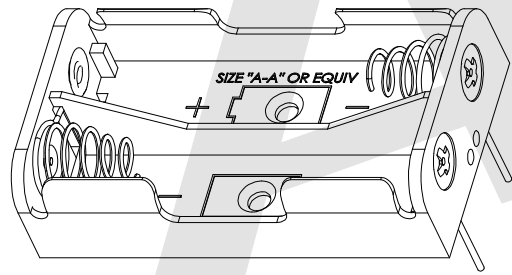
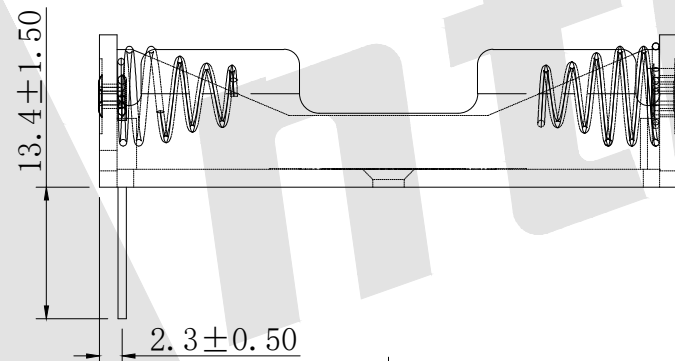
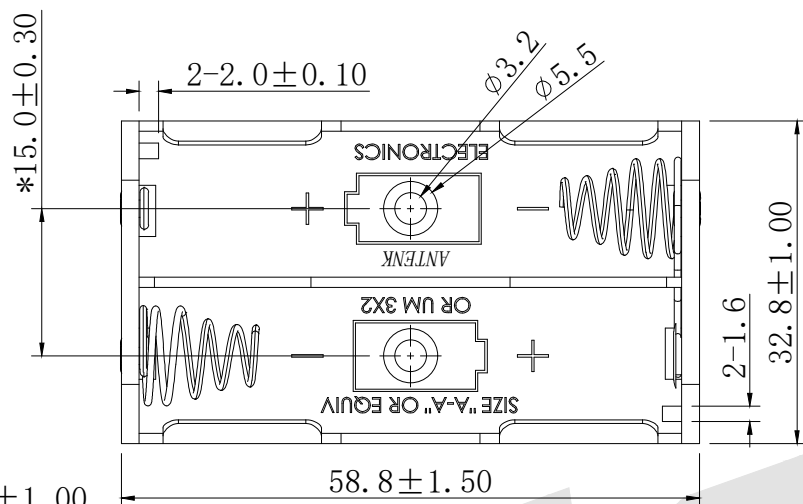
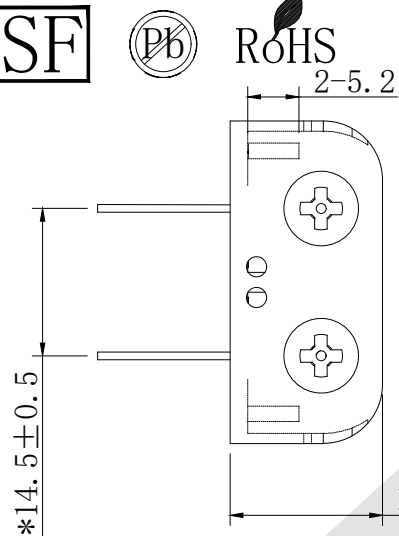

NOTES/说明:

- 1、HOLDER MATERIAL/胶芯材料:POLYPROPYLENE/聚丙烯.
- 2、SPRING MATERIAL/弹簧材料:MUSIC WIRE/钢琴线, 0.7DIA FINISH/电镀:NICKEL PLATE/镀镍
- 3、SOLDED LUG MATERIAL焊线端子: BRASS/黄铜, 0.8DIA FINISH-NICKEL PLATE /镀镍
- 4、The size marked with "*" is the key size.带"*"尺寸为重点尺寸

BBA - 5 - 2 - B - P - 462
 ① ② ③ ④ ⑤ ⑥

- ① BBA:Battery Holders/电池盒
- ② BATTERY TYPE/电池类型
5: AA SIZE
- ③ BATTERY NUMBERS/电池数量
2: 2 piece/2个
- ④ Packing/包装方式
A:TRAY B:BAG
- ⑤ P:With Pins/插板式
- ⑥ Series Number/序列号
462

Unless Otherwise specified tolerance
 X. ±0.35 X.XX: ±0.20
 X.X: ±0.25 X.XXX: ±0.15

SCALE: As Shown UNIT: mm
 DRAW Lv Xun Hua DATE 29/03/2019
 CHECK BobYang DATE 29/03/2019

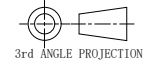

Antenk ANTENK ELECTRONICS CO., LTD
[Http://www.antenk.com](http://www.antenk.com)
 E-mail:sales@antenk.com

TITLE: DUAL AA Battery Holders DIP TYPE
 双胞5号电池盒插板式

DRAWING NO: BBA-5-2-B-P-462
 PRODUCT NO: BBA-5-2-B-P-462

REV	DESCRIPTION	DATE
1		