

HSF



Material:
Base: PA46+30%GF, BLACK, UL94V-0;
CONTACT: 0.3MM THK STAINLESS STEEL
FINISH: BRIGHT TIN 200U" OVER NICKEL 50U"

BBC - S - SN - A - 097

① ② ③ ④ ⑤

① BBC: Battery Holder 电池盒
② Apperance for the product 连接形式

S: 180°

③ Contact Plating 端子电镀

SI: Tin NICKEL Plated 锡镍合金

G2: 5U" Gold 金

SN: Tin 锡

G3: 10U" Gold 金

GO: Gold flash 普金

G4: 15U" Gold 金

G1: 3U" Gold 金

G5: 30U" Gold 金

④ Packing method 包装方式

A: Tray packing 吸塑盒装

B: BAG 袋装

⑤ Product number 产品编号

097

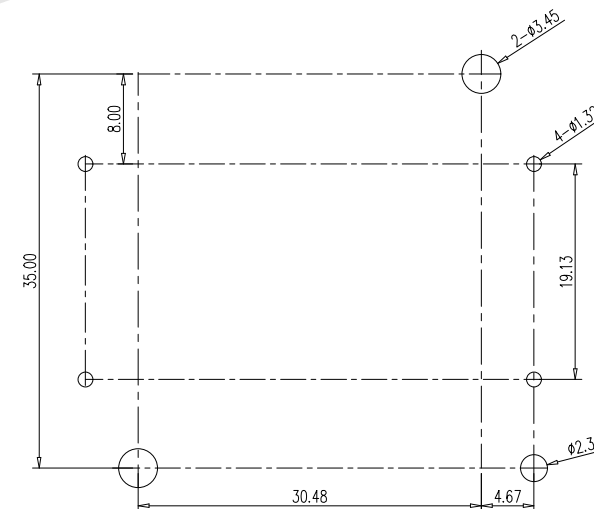
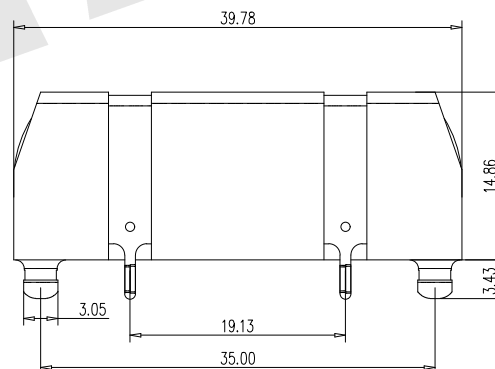
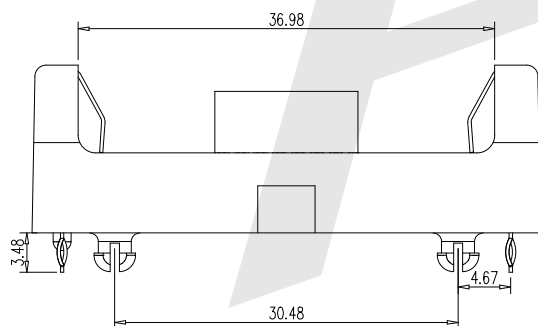
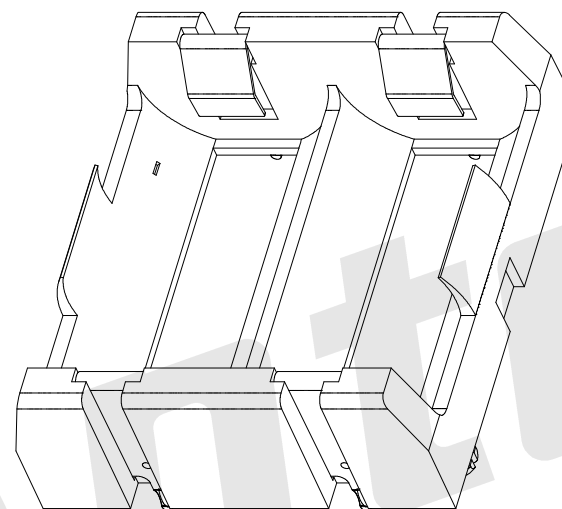
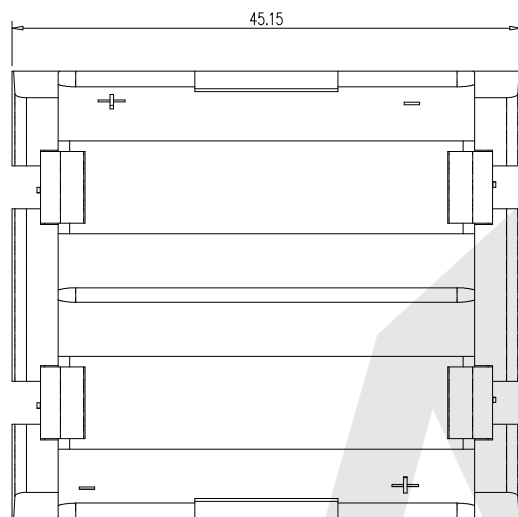

Unless Otherwise specified tolerance
X.±0.35 X.XX:±0.20
X.X:±0.25 X.XXX:±0.15

SCALE: As Shown UNIT: mm
DRAW YH DATE 1/2/2024
CHECK BobYang DATE 1/2/2024
VER./版本号



Antenk® ANTENK ELECTRONICS CO., LTD
Http://www.antenk.com
E-mail:sales@antenk.com

TITLE: Dual Battery Holder For 18350 THM

DRAWING NO: BBC-S-SN-A-097

PRODUCT NO: BBC-S-SN-A-097

MK/标记

DESCRIPTION/修订内容

DATE/日期(M/D/Y)