

HSF

ROHS

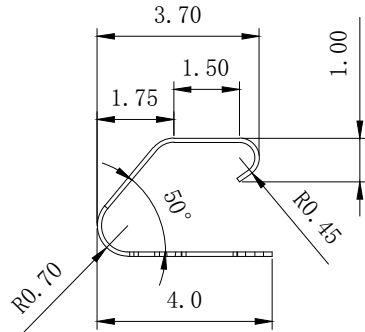

COMONENT SETAIL

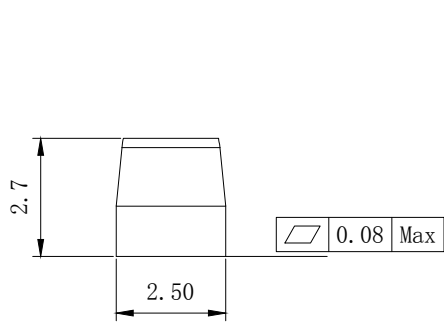
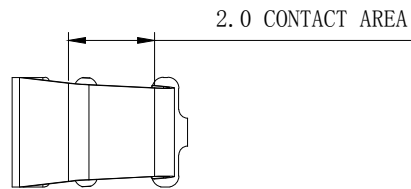
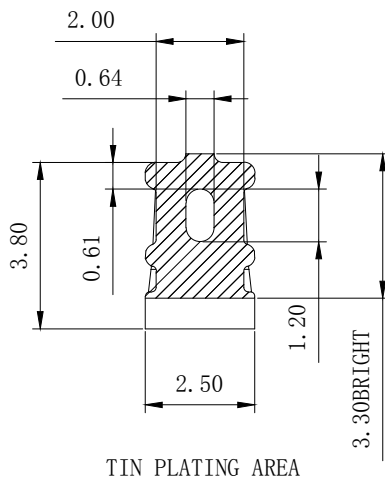
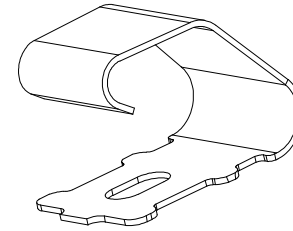

1. Material: Titanium Copper T= 0.10mm
 2. Contact Area: Au 0.8u "; Gold Plating in Other Area Nickel Base 30U "min;
 3. Salt Spray 24H
 4. Recommended Working Height=2.30mm/min Force=1.2N
 5. Recommended Minimum Working Height=1.90mm
- ELECTRICAL:
Current Rating:6A
- MECHANICAL:
Durability:2000 Cycles
- Environmental:
Operating Tempertupe:-55° C TO +125° C.

Ordering Code:

S7091 - 42R - X

PACKING:

B:Bag

T:Tape & Reel

Unless Otherwise specified tolerance	
X. ±0.5	X.XX: ±0.25
X.X: ±0.38	X.XXX: ±0.15
SCALE: As Shown	UNIT: mm
DRAW Wu Feng Rong	DATE 09/21/2021
CHECK BobYang	DATE 09/21/2021

Antenk ANTENK ELECTRONICS CO., LTD
[Http://www.antenk.com](http://www.antenk.com)
 E-mail:sales@antenk.com

TITLE:

SMT SHIELD FINGER 2.7

DRAWING NO:

S7091-42R-X

PRODUCT NO:

S7091-42R-X



REV	DESCRIPTION	DATE
1		
2		
3		
4		
5		

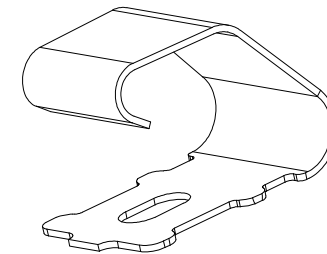
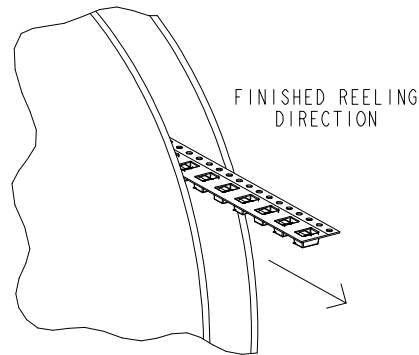
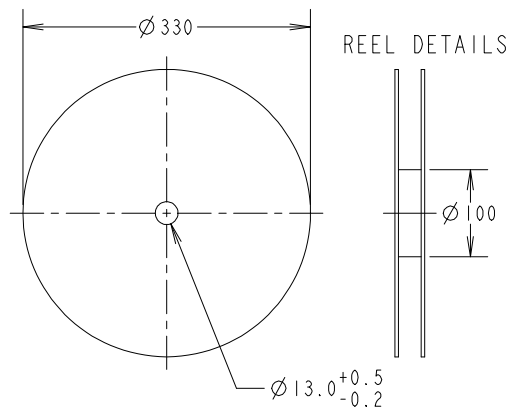
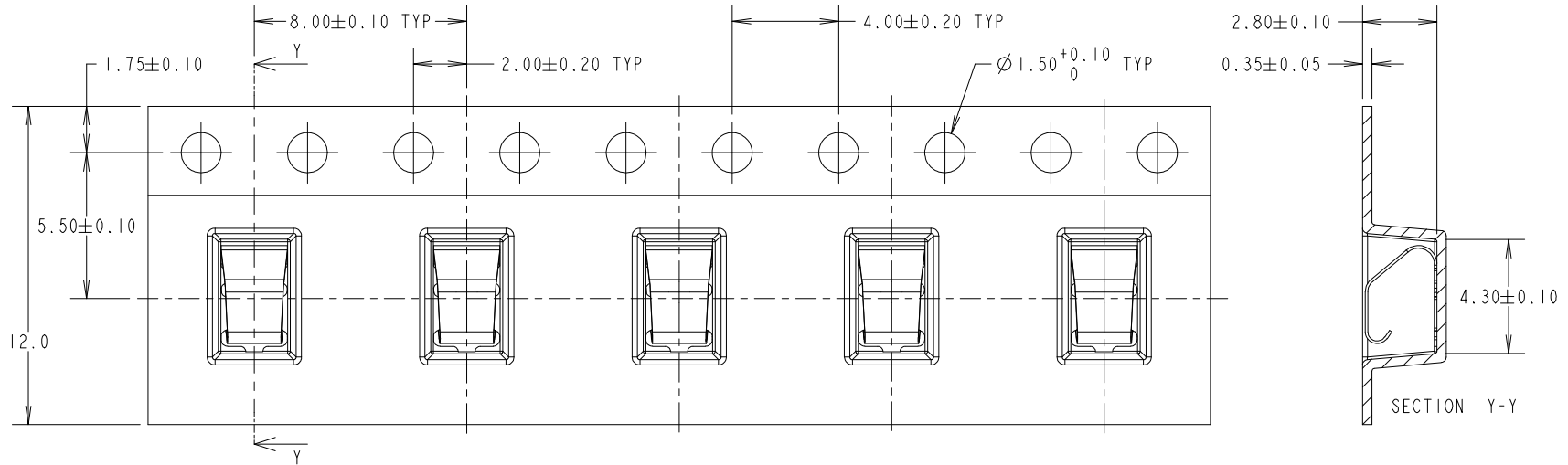

NOTES:
QUANTITY PER REEL=2500 PCS

Unless Otherwise specified tolerance
X. ± 0.5 X.XX: ± 0.25
X.X: ± 0.38 X.XXX: ± 0.15

Antenk® ANTENK ELECTRONICS CO., LTD
Http://www.antenk.com
E-mail:sales@antenk.com

SCALE: As Shown	UNIT: mm
DRAW Wu Feng Rong	DATE 09/21/2021
CHECK BobYang	DATE 09/21/2021

TITLE:
SMT SHIELD FINGER 2.7 IN TAPE AND REEL

DRAWING NO: S7091-42R-X

PRODUCT NO: S7091-42R-X



REV	DESCRIPTION	DATE
1		
2		
3		
4		
5		