

## Rack Type Steel Roll Scale

### Product Survey

It uses rack type platform structure, one bracket is installed on platform, and it hasn't buffer.

### Product Application

It can be widely used for online weighing of wires and bundles in hot and cold rolling steel roll lines.

### Advantageous Feature

It uses rack structure design, V-shape channel surface is installed with removable protective plate, and platform is stable and reliable;

Rational rack size, without elevation influence by chain conveyor, accurate and reliable weighing;

It has excellent scale frame structure, and balance force transmission guarantees operating life of load cell;

Combined use of tension rod and top limit removes influence by scale frame shake, and it has quick and reliable weighing.

### Photo

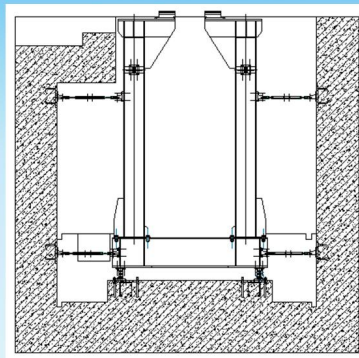

### Relevant products

BM-LS load cell

CZL-YB load cell

XK3102 weighing indicator

XK3105/C weighing indicator

JXHP junction box

DX562/106 large screen

Specifications

Customizing according to user's steel plate roll specifications.