

NS-6020

活動氣動裁片架

Movable Pneumatic Material Clip Stand

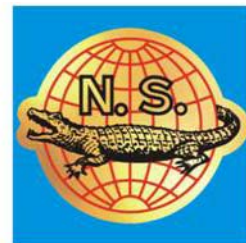

車縫中間段 In sewing

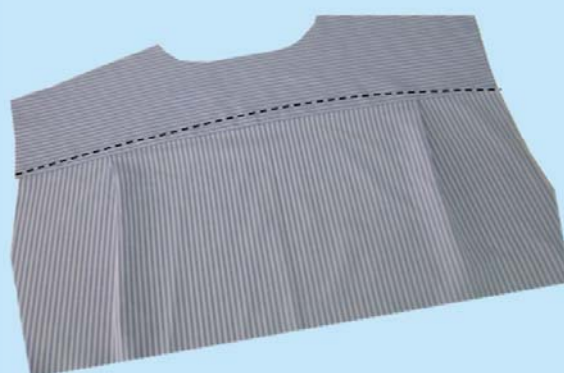

- 適用於輔助車縫擔桿裁片
- 工作時，裁片夾可調至與衣車同步，令車縫更順暢，完成後自動回位
- 電氣動操作
- 最多可以夾40件，無須手工收料，且疊放整齊，有助於提高效率

跟機件:

短檯板、腳架

- Suitable for facilitating yoke pieces sewing
- Cut pieces clip can act in step with sewing machine so that the sewing operation run smoothly, then it will automatically return to original position
- Electric-pneumatic operation
- Maximum 40 pieces can be stacked in good order, no need of manual material collection by operator, thereby to achieve high efficiency

Standards:

Short Table, Stand



車縫開始段 Start sewing



車縫完成段 Finishing section

跟機件 Standards:



A1013-1 短檯板
Short Table

A3001-2 L型車腳架
L-shaped Stand

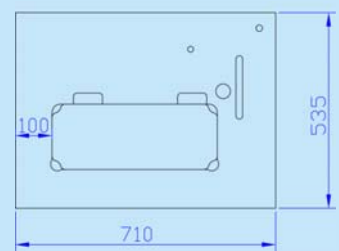
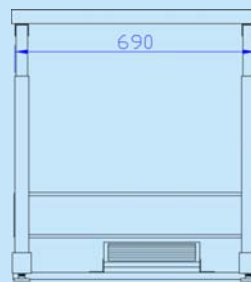

短檯板尺寸
Short Table Dimensions

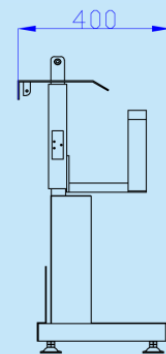
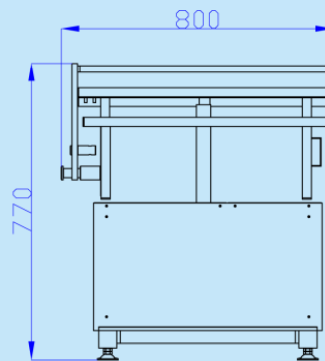

機身尺寸
Machine Size Diagram

型號 Model	適用衣車頭品牌 Applicable Sewing M/c Head Brand	適用衣車頭機型 Applicable Sewing M/c Head Model	電源 Power Supply	總功率(kW) Total Power	壓縮空氣壓力 (kgf/cm ²) Compressed Air Pressure	耗壓縮空氣量(L/min) Compressed Air Consumption	淨重(kg) Net Weight	毛重(kg) Gross Weight	機身尺寸(mm) Machine Size
NS-6020	重機 JUKI	DDL-5550N	1PH/220V/50Hz	0.2	5	6	53	73	800x400x770
		DDL-5550N-3							
		DDL-5550N-7							
		DDL-8700							
		DDL-8700-7							
		DDL-9000A							
	兄弟 BROTHER	DDL-9000B							
		DB2-737-413							
		DB2-B735							
		S-7200A							
		S-7200B							



藝誠(余氏)發展有限公司
Ngai Shing Development Limited

香港九龍長沙灣永康街52號地下
G/F., 52 Wing Hong St.,
Cheung Sha Wan, Kln., Hong Kong.

Tel: (852) 2741 9981, 2742 0078 E-MAIL: info@ngaishing.com
Fax: (852) 2785 3149 Http://www.ngaishing.com