

NS-85P-1 / NS-85P-1-L

自動焗袖口機

Automatic Cuff Blocking Machine

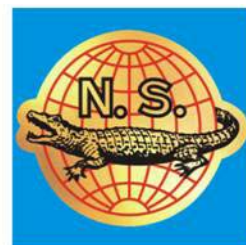

NS-85P-1



- 適合襯衫袖口壓熨，使間面線更容易
- 采用PLC可編程控制器控制及人性化操作界面觸摸顯示屏操作
- 只有下模發熱，可成型及壓平袖口，NS-85P-1跟機袖口模寬度為 9 1/4"~12 1/4"，NS-85P-1-L跟機袖口模寬度為 12" ~ 16"
- 上料模采用底夾
- 備吹風功能，輔助收料，提高工作效率
- 平均產量每8小時達到2400件

選購件：

- 圓角袖口模
- 四方袖口模
- 六角袖口模

- Suits for pressing shirt cuff so as to facilitate cuff topstitching
- Adopt PLC and user friendly touch screen for operation
- Only the lower mould has heater; it can shape and press cuff; NS-85P-1 standard cuff template width range: 9 1/4"~12 1/4", NS-85P-1-L standard cuff template width range: 12"~16"
- Cuff template with bottom clamp
- With air blowing function to assist cuff collection and boost production efficiency
- Average output: 2400 pcs/8hrs

Options:

- Round Corner Cuff Template
- Square Cuff Template
- Hexagonal Cuff Template

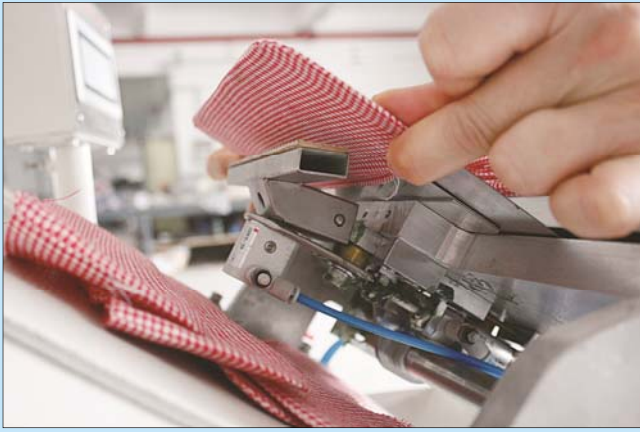

自動底夾，防止操作時袖口移位
Automatic bottom clamp for avoiding cuff shift

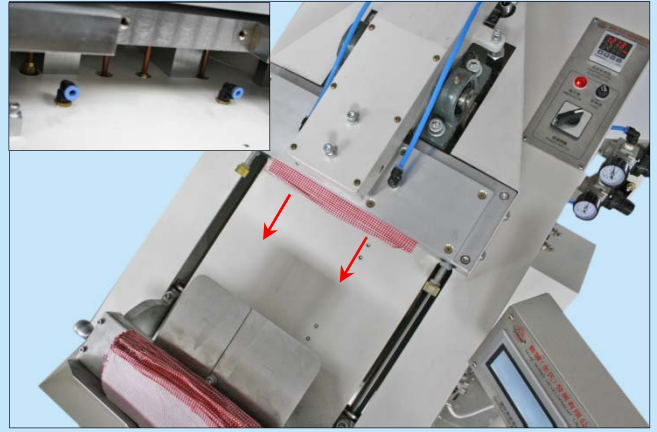

吹風自動收料
Air blowing facilitates automatic cuff collection

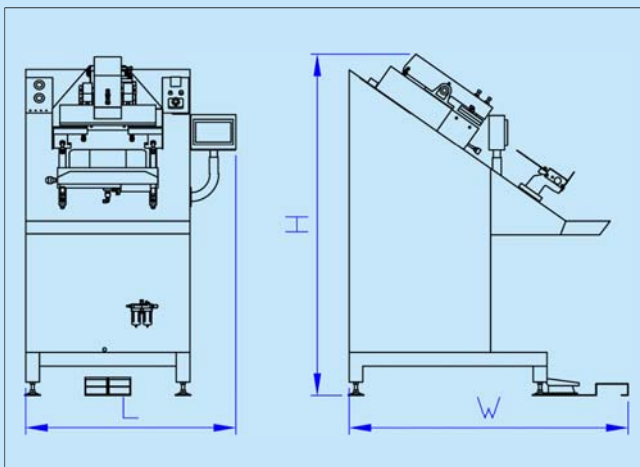

機身外形尺寸圖
Machine external dimensions diagram



優質電器元件
Quality electric elements

NS-85P-1		NS-85P-1-L		
(選購 Option)	(跟機 Standard)	(選購 Option)	(選購 Option)	(跟機 Standard)

型號 Model	電源 Power supply	總功率 (kW) Total power	壓縮空氣壓力(kg/cm ²) Compressed Air Pressure	耗壓縮空氣量(L/min) Compressed Air Consumption	機身尺寸(LxWxH)(mm) Machine Size
NS-85P-1	1PH/220V/50Hz	2	5	80	700x830x1320
NS-85P-1-L					780x1040x1320



藝誠(余氏)發展有限公司
Ngai Shing Development Limited

香港九龍長沙灣永康街52號地下
G/F., 52 Wing Hong St.,
Cheung Sha Wan, Kln., Hong Kong.

Tel: (852) 2741 9981, 2742 0078 E-MAIL: info@ngaishing.com
Fax: (852) 2785 3149 Http://www.ngaishing.com