

NS-2610
粘合機
Fusing Machine



- 適用於領、下級、介英等裁片粘合
- 采用兩次加壓，粘合效果佳
- 輸送帶速可調校，自動輸送帶平衡系統
- 前面入料、收料，操作方便，工作效率高
- 配獨立冷水機，冷卻效果佳
- 機身堅固耐用，維修容易

- It is suitable for fusing collar, collar band, cuff, etc.
- Double press acting to get finest result
- The speed of the belt is adjustable and the belt could be balanced by a built-in self balancing system
- Front feeding and front collecting to make operation easier and attain high efficiency
- Equipped with an independent water cooling device for fine cooling effect
- Machine body is durable, easy to repair



入料 Feeding

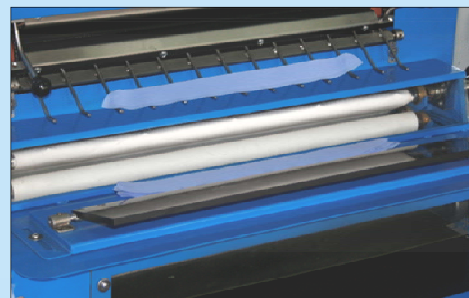

收料 Collecting

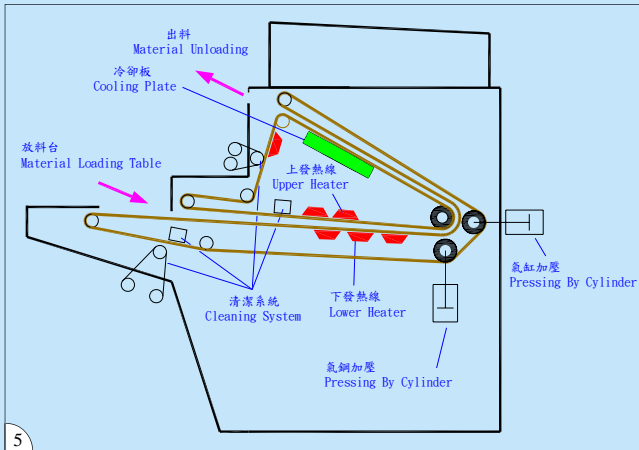
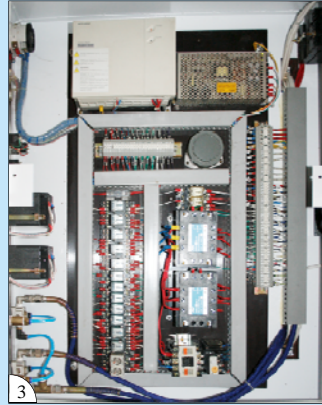

- 1、控制面板 Control Panel
- 2、冷水機 Water Cooling Device
- 3、優質電器元件 Optimum Electric Elements
- 4、加壓系統 Pressing System
- 5、工作原理圖 Working Principle Diagram

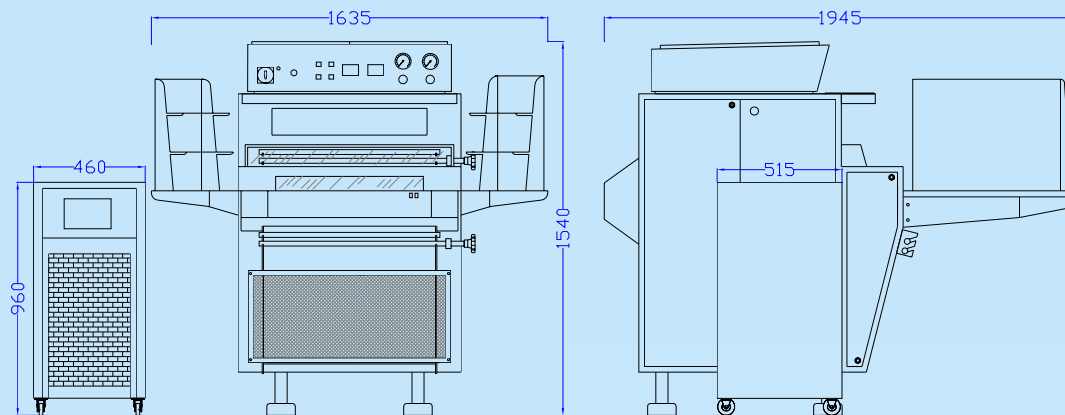

型號 Model	電源 Power Supply	總功率(kW) Total Power	壓縮空氣壓力 (kgf/cm ²) Compressed Air Pressure	耗壓縮空氣量(L/min) Compressed Air Consumption	平均粘合壓力(kgf/cm ²) Average Fusing Pressure	帶速(m/min) Belt Speed	粘合寬度(mm) Fusing Width	最高設計溫度(°C) Max. Design Temp.	機身尺寸 (mm) Machine size
NS-2610	3PH/380V/50Hz	9	5	5	1	0.7 ~ 2.6	600	200	1635x1945x1540



藝誠(余氏)發展有限公司
Ngai Shing Development Limited

香港九龍長沙灣永康街52號地下
G/F., 52 Wing Hong St.,
Cheung Sha Wan, Kln., Hong Kong.

Tel: (852) 2741 9981, 2742 0078 E-MAIL: info@ngaishing.com
Fax: (852) 2785 3149 Http://www.ngaishing.com