

NS-6049J-1

半自動包襯衫下級領間線收料架

Semi-Automatic Shirt Collar Stand Hemming Top Stitching Stacker



	2	3500RPM	DPx17 75/11	

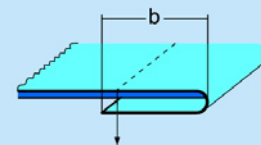

- 適用於梳織襯衫包下級
- 配合F560包下級樸蝴蝶使用，並加裝收料架，可自動疊放領，整齊美觀且效率高
- 裁片放入蝴蝶後，機器自動執行車縫和收料，適合生手工人操作

跟機件：

縫紉機(JUKI DDL-8000A-SMSOBK)

F560 包下級樸蝴蝶

P742 3/16"右傍吊傍壓腳

- Suitable for hemming collar band of woven shirts
- Used in combination with F560 Collar Band Interlining Attachment; one stacker is added for laying collars in order
- After cut piece feeding into attachment, machine will automatically perform sewing and collecting; therefore, even unskilled worker can handle it at ease

Standards:

Sewing machine (JUKI DDL-8000A-SMSOBK)

F560 Collar Band Interlining Attachment

P742 3/16" Right Flexible Guide Presser Foot



開始縫紉 Start sewing



第一裁片縫紉結束 First piece finished



收料 Collecting

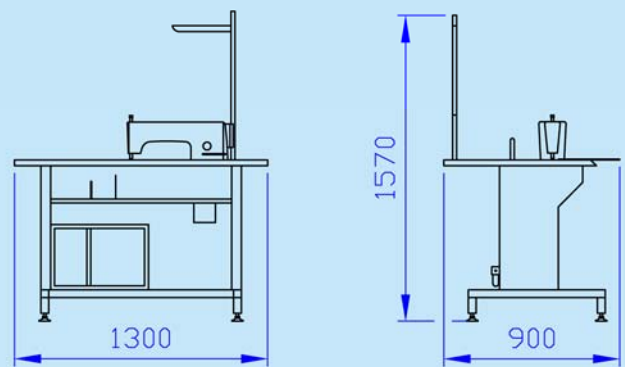

機身尺寸 Machine size

針距 Stitch Length(mm): 1.7

車速 Speed(RPM): 3500

車縫長度 Sewing length (mm): 470

產量 Output(pcs/hr): 520

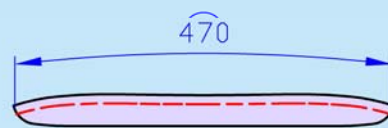

型號 Model	適用衣車頭機型 Applicable Sewing Head Model	電源 Power Supply	總功率(kW) Total Power	最大收料尺寸(mm) Max. Collectable Material Size	壓縮空氣壓力(kgf/cm ²) Compressed Air Pressure	耗壓縮空氣量 (L/min) Compressed Air Consumption	機身尺寸(mm) Machine Size
NS-6049J-1	JUKI DDL-8000A	1PH/220V/50Hz	0.55	500	5	10	1300x900x1570



藝誠(余氏)發展有限公司
Ngai Shing Development Limited

香港九龍長沙灣永康街52號地下
G/F., 52 Wing Hong St.,
Cheung Sha Wan, Kln., Hong Kong.

Tel: (852) 2741 9981, 2742 0078 E-MAIL: info@ngaishing.com
Fax: (852) 2785 3149 Http://www.ngaishing.com