

**NS-58**

**自動對邊捲布驗布機**

**Cloth Winding Inspection Machine with Edge Control Device**



NS-58L-72

- 適用各種布料的驗布及捲布，尤其適合梭織布的捲驗
- 採用電眼和油壓自動對邊裝置，對邊效果佳
- 捲布採用無段電子變速
- 可調校捲布張力，實現硬捲或軟捲，方便不同的捲布需求
- 捲布主軸可前轉或後轉，方便驗布需求
- 備電子計數表，可米/碼轉換(默認單位:米)，方便記錄布匹長度，精度： $\pm 0.5\%$
- 上燈罩配下燈箱，使驗布更清晰

**選購件：**

自動鬆布系統

自動展布系統

- Suitable for winding and inspecting various fabrics, especially for woven fabric
- Electric eye and hydraulic edge alignment device offer superb edge control
- Electric continuous winding speed variation
- As per different cloth winding requirement, it can perform tensed or relaxed winding through tension adjustment
- Winding main shaft can rotate forward or reversely to facilitate cloth inspection
- With meter/yard(default: m) switchable digital counter to record cloth length, precision:  $\pm 0.5\%$
- Upper lamp shade and lower light box provide clear view for cloth inspection

**Options:**

Automatic Fabric Loosening System

Automatic Fabric Spreading System

**跟機件 Standard:**



電子計數表(可米/碼轉換)  
Electronic Meter(Meter/Yardage Switchable)



自動追蹤對邊裝置  
Automatic Edging Track Device

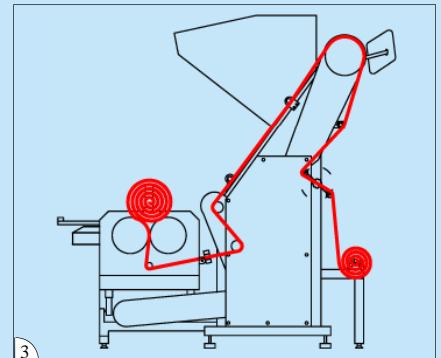

上布示意圖  
Fabric routing diagram

**選購件 Options:**



自動展布系統  
Automatic Fabric Spreading System



自動鬆布系統  
Automatic Fabric Loosening System

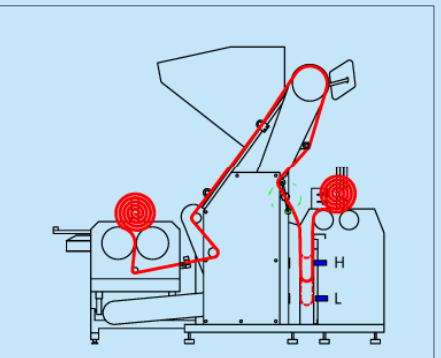

型號 Model	選購件 Options	
	自動鬆布系統 Automatic Fabric Loosening System	自動展布系統 Automatic Fabric Spreading System
NS-58H-72	O-A-06-04	O-A-10-01
NS-58L-72	O-A-06-01	
NS-58H-84	O-A-06-05	O-A-10-02
NS-58L-84	O-A-06-02	
NS-58H-96	O-A-06-06	O-A-10-03
NS-58L-96	O-A-06-03	

型號 Model	電源 Power Supply	總功率(kW) Total Power	捲布馬達功率(kW) Winding Motor Power	工作寬度(inch) Working Width	捲布直徑(inch) Cloth Winding Diameter	捲布速度(m/min) Cloth Winding Speed	最大承重(kg) Max. Load Bearing Capacity	機身尺寸 (mm) Machine Size		
NS-58H-72	3PH/380V/50Hz	2.8	2.2	72	15	2~35	95	2590x1800x1870*		
NS-58H-84				84				2880x1800x1870*		
NS-58H-96				96				3180x1800x1870*		
NS-58L-72		2.2	1.5	84	12			60	2590x1750x1870*	
NS-58L-84									84	2880x1750x1870*
NS-58L-96									96	3180x1750x1870*
NS-58鬆布系統(選購件) Fabric Loosening System (option)	1PH/220V/50Hz	0.37	0.37*	72	-	-	-		2420x750x1100	
				84	-	-	-		-	2650x750x1100
				96	-	-	-		-	2950x750x1100



**藝誠(余氏)發展有限公司**  
**Ngai Shing Development Limited**

香港九龍長沙灣永康街52號地下  
G/F., 52 Wing Hong St.,  
Cheung Sha Wan, Kln., Hong Kong.

Tel: (852)2741 9981, 2742 0078 E-MAIL: info@ngaishing.com  
Fax: (852)2785 3149 Http://www.ngaishing.com