

NS-8401P

自動恤衫袖山縫壓平機

Automatic Shirt Armhole Press

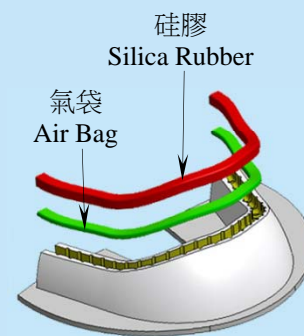

- 適用於襯衫袖山縫粘合壓熨
- 采用PLC可編程控制器控制及人性化觸摸顯示屏操作
- 垂直加壓方式，壓力分佈均勻，壓熨更平整
- 微壓、輕壓、脈沖、重壓四種壓熨方式供選擇設定，可滿足不同面料需求
- 上模加熱采用三個獨立數字式溫度控制器控制，溫度更控制精確
- 下模氣袋配合耐壓的高溫矽膠條，可消除袖山縫壓熨時袖山縫與後擔桿骨位的厚薄偏差，達到最佳壓熨效果
- 獨立真空抽濕泵，有助衣物定位、冷卻，定型效果佳
- 備有不同的袖山縫模，可來樣測試選擇合適的一款跟機模

選購件:

O-J-01-5 吹風冷卻系統(壓縮空氣)
各種袖山模(A款~K款)

- Suitable for shirt armhole fusing and pressing
- Adopt PLC and user friendly touch screen for operation
- Vertical pressing mode provides uniform pressure distribution and smooth effect
- Four pressing modes, i.e. slight press, light press, pulse press and heavy press, are available for selection to cater for different fabrics
- With three independent digital thermostats for accurate temperature control of upper mould
- Lower mould airbag combined with pressure-proof high temperature silica rubber, can offset the thickness difference between armhole and back yoke seam, thereby to achieve perfect pressing effect
- With independent vacuum pump to facilitate garment fixing, cooling and shaping
- Different armhole moulds available for sample test and select one of them as standard

Optional Accessories:

O-J-01-5 Compressed air blowing cool down system
Various armhole moulds(type A~K)

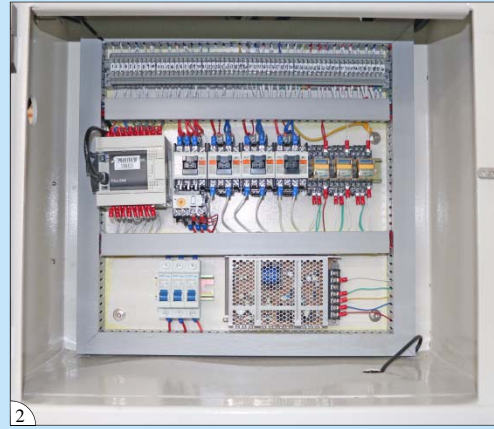

1. 高質矽膠及氣袋，自動充氣
2. 優質電器元件
3. 獨立真空泵，有助衣物定位，冷卻、定型效果佳
4. PLC可編程控制器控制及人性化操作 界面觸摸顯示屏操作

選購件Optional Accessories:

O-J-01-5 吹風冷卻系統(壓縮空氣) Compressed air blowing cool down system

1. High quality silica rubber and air bag for automatic air charging
2. High quality electric elements
3. Independent vacuum pump for easy garment positioning, cooling down and the shaping effect is fine
4. Adopt PLC and human friendly touch screen for operation

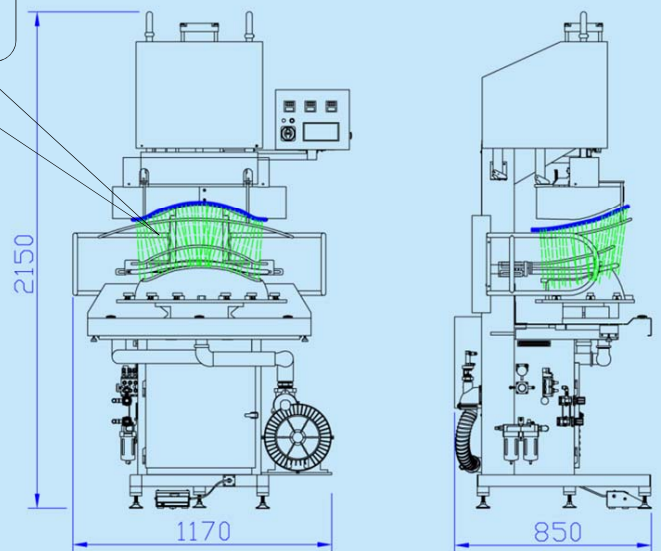

型號 Model	電源 Power Supply	總功率(kW) Total Power	發熱線功率 (kW) Heater Power	真空泵功率(kW) Vacuum Pump Power	壓縮空氣壓力(kgf/cm ²) Compressed Air Pressure	耗壓縮空氣量(L/min) Compressed Air Consumption	平均粘合壓力(kgf/cm ²) Average Fusing Pressure	淨重(kg) Net Weight	機身尺寸(mm) Machine Size
NS-8401P	3PH/380V/50Hz	3.6	2.4	1.1	5	98	2.5	390	1170x850x2150



藝誠(余氏)發展有限公司
Ngai Shing Development Limited

香港九龍長沙灣永康街52號地下
G/F., 52 Wing Hong St.,
Cheung Sha Wan, Kln., Hong Kong.

Tel: (852) 2741 9981, 2742 0078 E-MAIL: info@ngaishing.com
Fax: (852) 2785 3149 Http://www.ngaishing.com

選購件 (每款模包括一個上模和一個下模)

Optional Accessories (Each type consists of one upper mould and one lower mould)



A款下模
Lower mould Type A
編號：M13050101-1

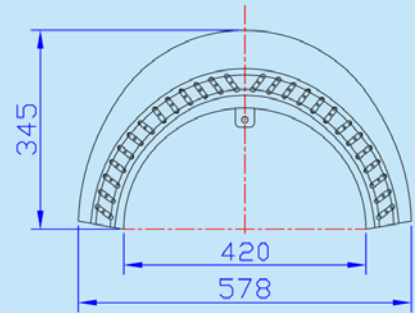

B款下模
Lower mould Type B
編號：M13050102-1

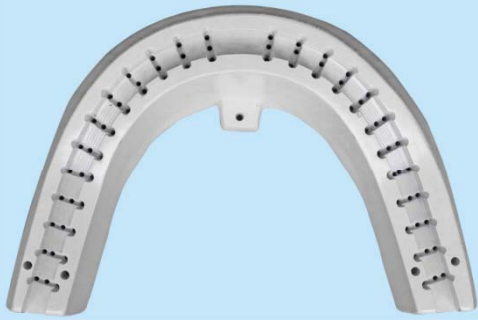
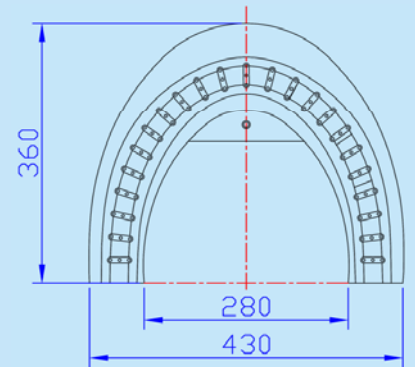

C款下模 (標準跟機模)
Lower mould Type C
(Standard)
編號：M13050103-1

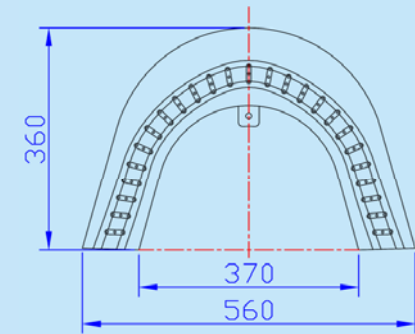

D款下模
Lower mould Type D
編號：M13050104

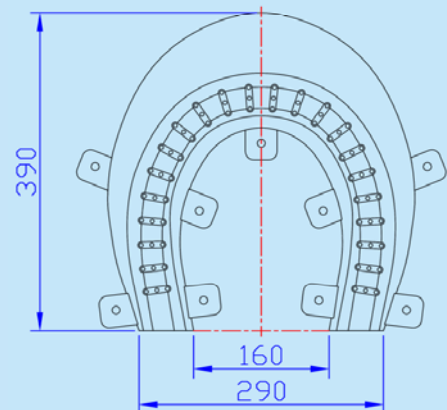

*



E款下模
Lower mould Type E
編號：M13050105

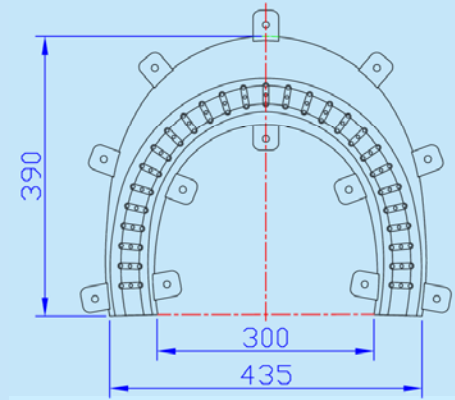

G款下模
Lower mould Type G
編號：M13050107-1

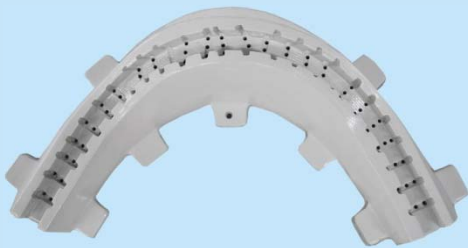
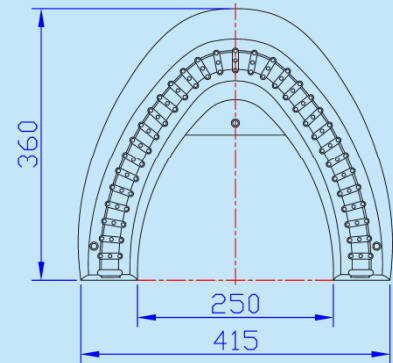

J款下模
Lower mould Type J
編號：M13050109

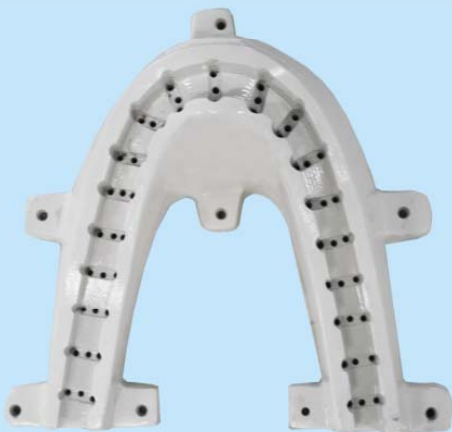
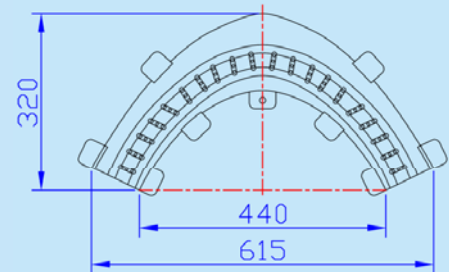

K款下模
Lower mould Type K
編號：M13050110

