

NS-9501

自動轉頭袖山縫壓平機

Automatic Rotation Armhole Press

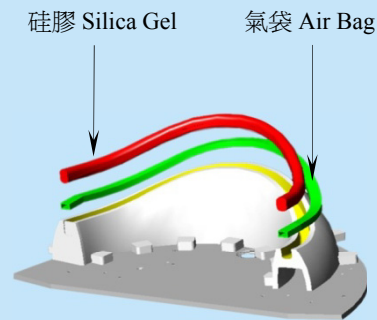

特別設計下模，徹底消除模與襯衫袖山縫形狀間的偏差 Specially designed lower mould can completely eliminate the shape difference between the mould and shirt armhole

- 適用於袖山縫交替粘合壓熨
- 採用PLC控制器控制及人性化觸摸顯示屏操作
- 採用垂直加壓方式，壓熨更平整，壓力效率更大
- 輕壓、重壓兩種壓熨方式供選擇設定，可滿足不同面料需求
- 上模加熱採用三個獨立數字式溫度控制器控制，溫度控制更精確
- 自動旋轉式下模，操作方便、工作效率高
- 單發熱上模配合雙下模交替式操作，可節省電力
- 下模氣袋再配合矽膠條(耐高溫、高壓)，可徹底消除模與襯衫袖山縫形狀間的偏差，配合不同布料達到完美壓熨效果
- 獨立真空泵，有助衣物定位，冷卻、定型效果佳
- Suitable for armhole fusing and ironing alternately
- Adopt PLC and user friendly touch screen for operation
- Vertical adding pressure mode for a more flat pressing effect and higher efficiency
- Two pressing modes (light press and heavy press) are available to meet the needs of different fabric
- Apply three independent digital thermostats for accurate temperature control of the upper mould
- Automatic rotation lower mould is easy to operate and can improve production efficiency
- One upper heating mould works with two lower moulds, saving power and improving work efficiency
- Lower mould airbag combines with silica rubber (high temperature and pressure resistant) which can eliminate the shape difference between mould and shirt armhole, so as to achieve perfect pressing effect
- Independent vacuum pump facilitates garment positioning, cooling and shaping

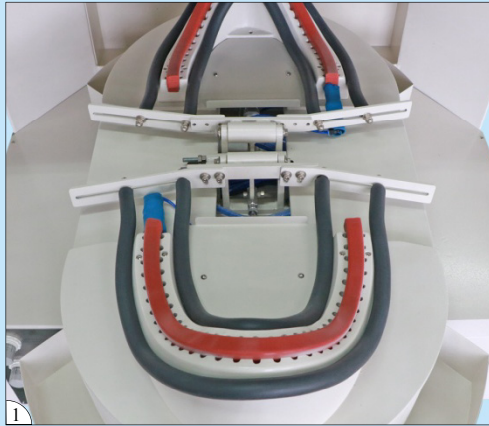

1. 高質硅膠及氣袋，自動充氣
2. 雙模操作，可同時鋪料和壓熨
3. 可根據需要調節不同區域壓力
4. PLC可編程控制器控制及人性化操作界面觸摸顯示屏操作

1. High quality silica rubber and air bag for automatic air charging
2. Double moulds perform alternatively , placing fabric and pressing are available at the same time
3. Different area pressure can be adjustable by need
4. Adopt PLC and human friendly touch screen for operation

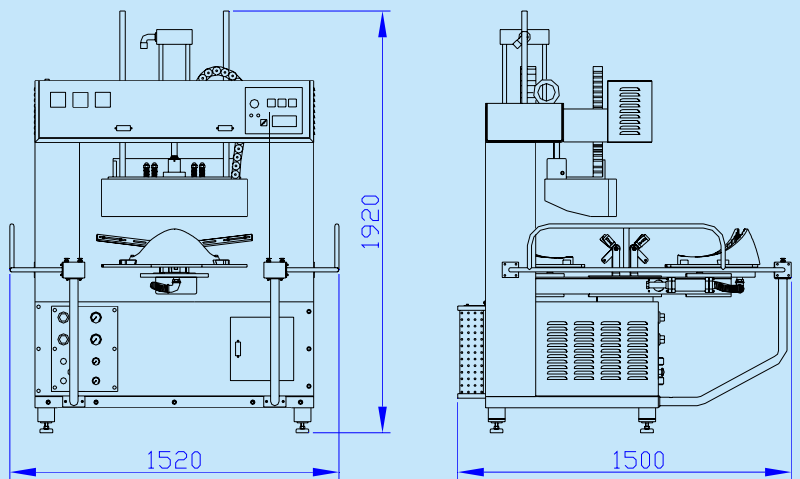

型號 Model	電源 Power Supply	總功率(kW) Total Power	發熱線功率 Heater Power (kW)	真空泵功率(kW) Vacuum Pump Power	壓縮空氣壓力 Compressed Air Pressure (kgf/cm ²)	耗壓縮空氣量 Compressed Air Consumption (L/min)	平均粘合壓力 Average Fusing Pressure (kgf/cm ²)	淨重(kg) Net Weight	機身尺寸(mm) Machine Size
NS-9501	3PH/380V/50Hz	4	2.4	1.5	5	180	2.5	846	1520x1500x1920



藝誠(余氏)發展有限公司
Ngai Shing Development Limited

香港九龍長沙灣永康街52號地下
G/F., 52 Wing Hong St.,
Cheung Sha Wan, Kln., Hong Kong.

Tel: (852)2741 9981, 2742 0078 E-MAIL: info@ngaishing.com
Fax: (852)2785 3149 Http://www.ngaishing.com

選購件 (每款模包括一個上模和兩個下模)

Options (Each type consists of one upper mould and two lower moulds)

