

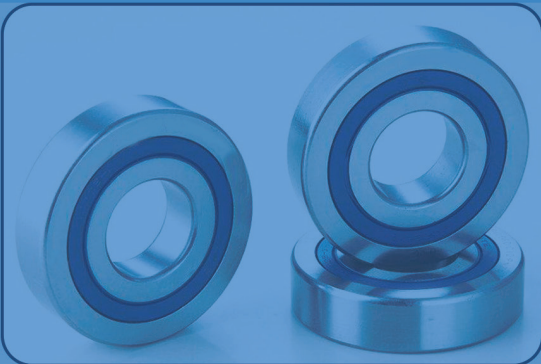

# HIGH PRECISION BALL BEARING

SCREWTECH BROCHURE



- Professional equipments
- Professional teams
- Professional solutions





## ABOUT US

Our WKT brand establish on 2007 with 14 years experience on ball screw manufacturer industry. We focus on constant product development which win good reputation in China and Overseas market.

Meanwhile, we also develop ball screw related product like linear motion products so that give customer overall system solution WKT brand advantages:

### 1.Ready stock:

We do ready stock for standard ball screw shafts with standard nuts, the minimum leading time is 3 days which quickly meet customer and distributor demand.

### 2.Customized design:

At the same time, customized ball screws with flexible design of ball screw shafts and ball screw nuts will make your unique technical design of a linear motion come true.

## Main Products

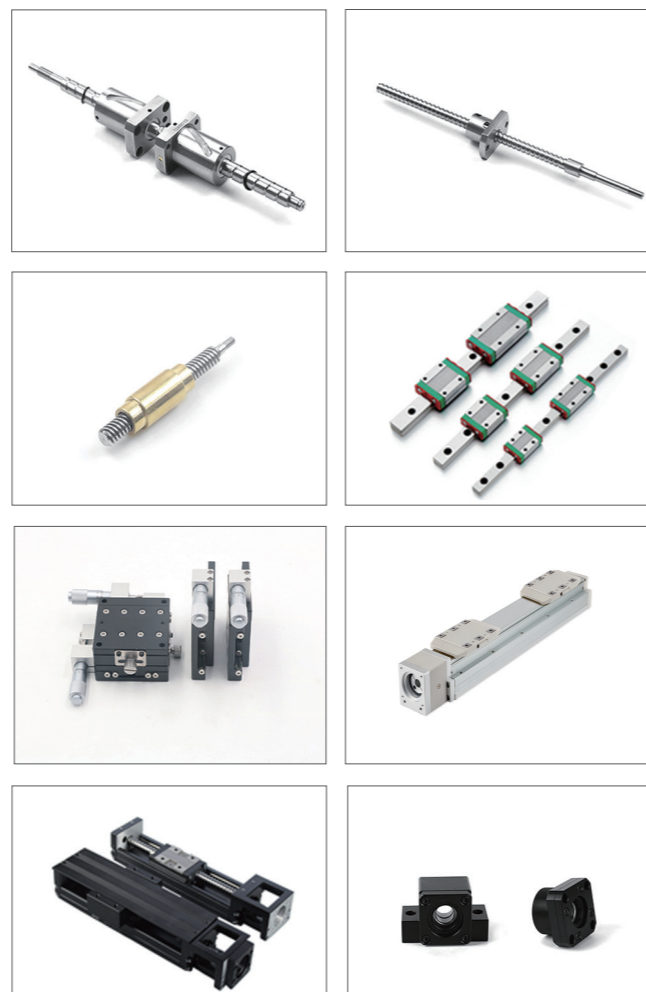

# CONTENTS



## 01

High speed angular contact bearing .....	04
70 series.....	04
72 series.....	08
718 series.....	12
719 series.....	16
B70 series.....	20

## 02

Ball screw support bearing .....	22
760 series.....	22
BSB series.....	24
TAD series.....	25

## 03

Precision deep groove ball bearing .....	26
60 series .....	27
62 series .....	28
63 series .....	29
160 series .....	30
618 series .....	31
619 series .....	32



## 70 series (Standard)

Nominal contact Angle  $\alpha = 15^\circ, 25^\circ$   
Inner diameter 6-150mm



Contact angle	C-15° or AC-25°
Rolling element	Steel ball or ceramic ball
Structure	Open or sealed
Holder	Nylon or bakelite
Precision	P5, P4, P2 level
Pairing	Provide any configuration of SU&GA universal matching level (DT, DB, DF, TBT, etc.)

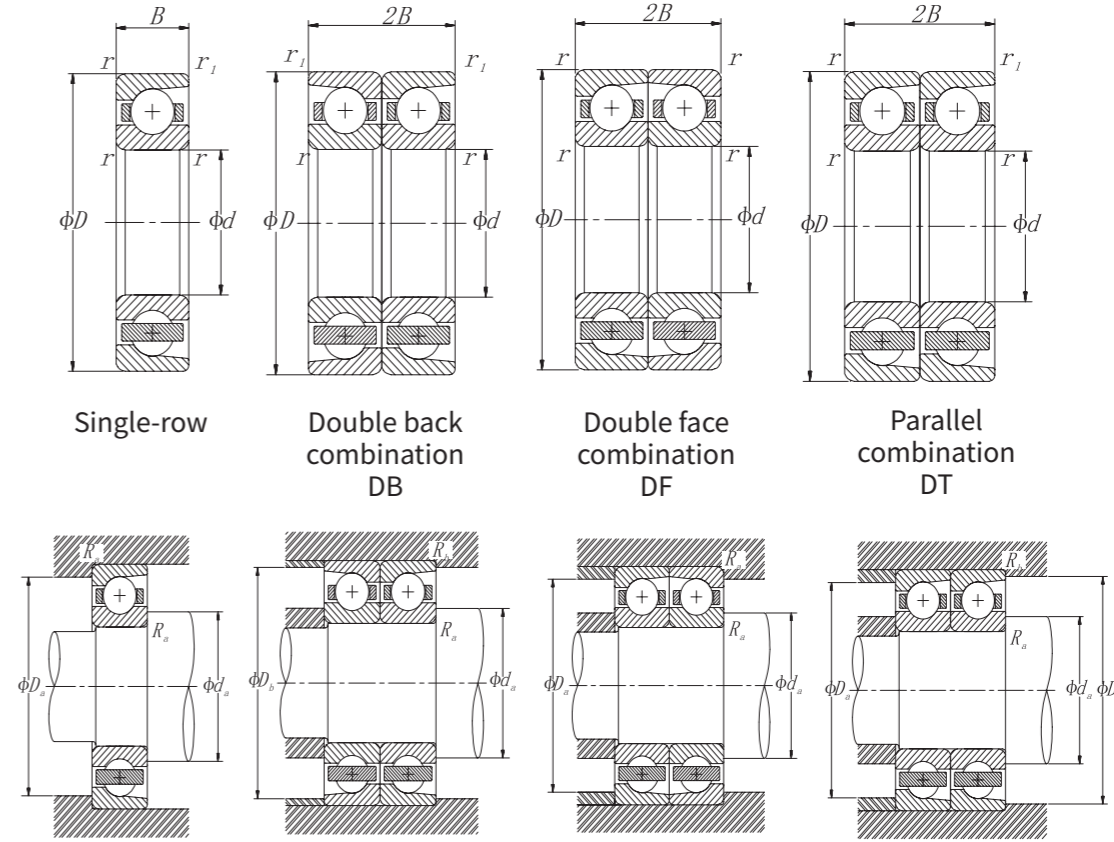

Model	Main dimensions (mm)					Basic rated load(KN)		Steel ball limit speed (r/min)		Ceramic ball limit speed (r/min)		Preload (N)			Weight (kg)
	d	D	B	r	r1	Cr	Cor	Lipid	Oil	Lipid	Oil	Light(A)	Medium(B)	Heavy(C)	
706C	6	17	6	0.3	0.3	2.36	0.97	95000	160000	120000	190000				
706AC	6	17	6	0.3	0.3	2.28	0.93	85000	140000	100000	170000				
708C	8	22	7	0.3	0.3	3.8	1.73	75000	120000	95000	160000				
708AC	8	22	7	0.3	0.3	3.75	1.66	67000	100000	80000	130000				
7000C	10	26	8	0.3	0.3	4.25	2.08	60000	90000	80000	130000	17	67	145	0.021
7000AC	10	26	8	0.3	0.3	4.05	2	56000	85000	67000	100000	22	100	224	0.021
7001C	12	28	8	0.3	0.3		2.6	56000	85000	70000	110000	19	74	161	0.024
7001AC	12	28	8	0.3	0.3	4.55	2.5	50000	75000	60000	90000	23	110	250	0.024
7002C	15	32	9	0.3	0.3	6.2	3.4	48000	70000	60000	90000	28	102	216	0.035
7002AC	15	32	9	0.3	0.3	6	3.25	43000	63000	50000	75000	36	154	344	0.035
7003C	17	35	10	0.3	0.3	8.65	4.9	43000	63000	53000	80000	41	146	308	0.045
7003AC	17	35	10	0.3	0.3	8.3	4.75	38000	56000	45000	67000	54	221	487	0.045
7004C	20	42	12	0.6	0.6	10.4	6	36000	53000	45000	67000	52	179	377	0.079
7004AC	20	42	12	0.6	0.6	10	5.7	32000	48000	38000	56000	71	277	598	0.079
7005C	25	47	12	0.6	0.6	14.6	9.15	30000	45000	38000	56000	74	254	533	0.091
7005AC	25	47	12	0.6	0.6	13.7	8.65	28000	43000	34000	50000	101	384	828	0.091
7006C	30	55	13	1	1	15	10.2	26000	40000	32000	48000	75	260	545	0.133
7006AC	30	55	13	1	1	14.3	9.8	24000	38000	28000	43000	102	397	861	0.133
7007C	35	62	14	1	1	19	13.7	22000	36000	28000	43000	91	333	697	0.17
7007AC	35	62	14	1	1	18.3	12.9	20000	34000	24000	38000	136	518	1116	0.17

Model	Main dimensions (mm)					Basic rated load(KN)		Steel ball limit speed (r/min)		Ceramic ball limit speed (r/min)		Preload (N)			Weight (kg)
	d	D	B	r	r1	Cr	Cor	Lipid	Oil	Lipid	Oil	Light(A)	Medium(B)	Heavy(C)	
7008C	40	68	15	1	1	20.4	16	20000	34000	26000	40000	102	353	743	0.21
7008AC	40	68	15	1	1	19.6	15	19000	32000	22000	36000	142	547	1180	0.21
7009C	45	75	16	1	1	27.5	21.2	18000	30000	24000	38000	145	490	1019	0.26
7009AC	45	75	16	1	1	26.5	20	17000	28000	20000	34000	209	768	1638	0.26
7010C	50	80	16	1	1	28.5	22.8	17000	28000	22000	36000	450	507	1054	0.29
7010AC	50	80	16	1	1	27	21.6	15000	24000	18000	30000	211	779	1663	0.29
7011C	55	90	18	1.1	1.1	38	31	15000	24000	19000	32000	207	687	1424	0.42
7011AC	55	90	18	1.1	1.1	36	29	14000	22000	17000	28000	298	1066	2257	0.42
7012C	60	95	18	1.1	1.1	39	33.5	14000	22000	18000	30000	211	704	1459	0.45
7012AC	60	95	18	1.1	1.1	36.5	31.5	13000	20000	15000	24000	299	1075	2281	0.45
7013C	65	100	18	1.1	1.1	40	35.5	13000	20000	17000	28000	216	720	1495	0.47
7013AC	65	100	18	1.1	1.1	38	33.5	12000	19000	15000	24000	310	1118	2372	0.47
7014C	70	110	20	1.1	1.1	50	43	12000	19000	16000	26000	278	915	1888	0.66
7014AC	70	110	20	1.1	1.1	46.5	41.5	11000	18000	13000	20000	398	1397	2945	0.66
7015C	75	115	20	1.1	1.1	51	46.5	12000	19000	15000	24000	283	931	1923	0.69
7015AC	75	115	20	1.1	1.1	48	44	11000	18000	13000	20000	408	1439	3027	0.69
7016C	80	125	22	1.1	1.1	63	58.5	11000	18000	14000	22000	357	1163	2391	0.93
7016AC	80	125	22	1.1	1.1	60	55	9500	16000	12000	19000	529	1830	3825	0.93
7017C	85	130	22	1.1	1.1	65.5	62	10000	17000	13000	20000	370	1209	2484	0.97
7017AC	85	130	22	1.1	1.1	62	58.5	9000	15000	11000	18000	545	1888	3949	0.97
7018C	90	140	24	1.5	1.5	76.5	72	9500	16000	12000	19000	440	1427	2925	1.26
7018AC	90	140	24	1.5	1.5	72	68	8500	14000	10000	17000	649	2217	4623	1.26
7019C	95	145	24	1.5	1.5	78	76.5	9000	15000	11000	18000	447	1452	2980	1.32
7019AC	95	145	24	1.5	1.5	75	72	8000	13000	9500	16000	675	2308	4813	1.32
7020C	100	150	24	1.5	1.5	81.5	81.5	8500	14000	11000	18000	467	1516	3112	1.37
7020AC	100	150	24	1.5	1.5	76.5	76.5	7500	12000	9000	15000	685	2347	4902	1.37
7021C	105	160	26	2	2	106	102	8000	13000	10000	17000	625	1999	4803	1.73
7021AC	105	160	26	2	2	102	98	7000	11000	8500	14000	960	3206	6639	1.73
7022C	110	170	28	2	2	110	110	7500	12000	9500	16000	648	2072	4235	2.14
7022AC	110	170	28	2	2	104	104	6700	10000	8000	13000	975	3262	6760	2.14
7024C	120	180	28	2	2	112	116	6700	10000	8500	14000	657	2107	4308	2.27
7024AC	120	180	28	2	2	106	110	6300	9500	7500	12000	989	3317	6881	2.27
7026C	130	200	33	2	2	143	150	6000	9000	7500	12000	857	2720	5545	3.43
7026AC	130	200	33	2	2	137	143	5600	8500	6700	10000	1322	4358	8972	3.43
7028C	140	210	33	2	2	146	160	5600	8500	7000	11000	873	2775	5657	3.64
7028AC	140	210	33	2	2	140	150	5000	7500	6300	9500	1345	4446	9159	3.64
7030C	150	225	35	2.1	2.1	183	193	5300	8000	6700	10000	1111	3503	7142	4.43
7030AC	150	225	35	2.1	2.1	173	186	4800	7000	5600	8500	1705	5555	11417	4.43

# 72 series (Standard)

Nominal contact Angle  $\alpha = 15^\circ, 25^\circ$   
 Inner diameter 10-130mm



Contact angle	C-15° or AC-25°
Rolling element	Steel ball or ceramic ball
Structure	Open or sealed
Holder	Nylon or bakelite
Precision	P5, P4, P2 level
Pairing	Provide any configuration of SU&GA universal matching level (DT, DB, DF, TBT, etc.)

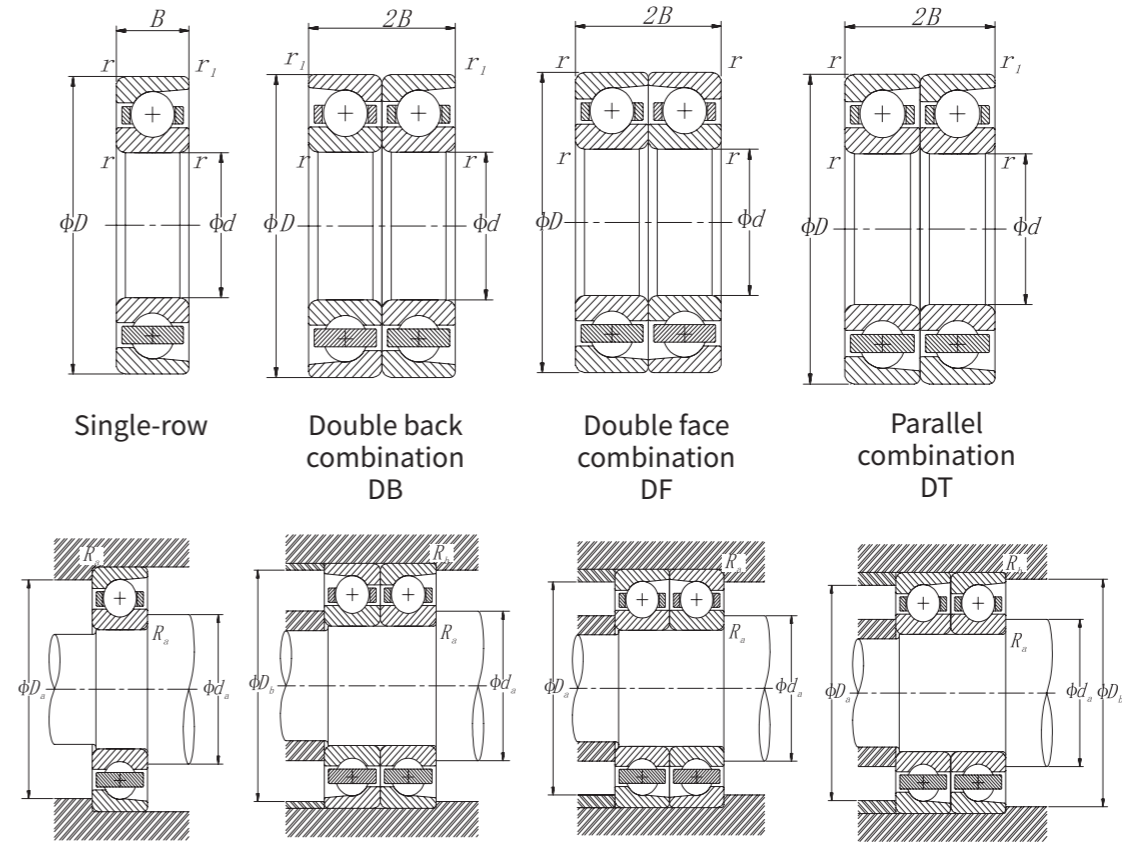

Model	Main Dimension(mm)					Basic rated load (KN)		Steel ball limit speed (r/min)		Ceramic ball limit speed (r/min)		Preload (N)		
	d	D	B	r	r1	Cr	Cor	Lipid	Oil	Lipid	Oil	Light(A)	Medium(B)	Heavy(C)
7200C	10	30	9	0.6	0.6	5.85	2.9	56000	85000	70000	110000	25	92	198
7200AC	10	30	9	0.6	0.6	5.6	2.8	50000	75000	60000	90000	31	139	312
7201C	12	32	10	0.6	0.6	7.65	3.9	50000	75000	63000	95000	35	124	264
7201AC	12	32	10	0.6	0.6	7.35	3.75	45000	67000	56000	85000	47	191	420
7202C	15	35	11	0.6	0.6	9.65	5	45000	67000	56000	85000	47	165	347
7202AC	15	35	11	0.6	0.6	9.3	4.8	40000	60000	48000	70000	65	256	555
7203C	17	40	12	0.6	0.6	10.8	5.85	38000	56000	50000	75000	53	186	391
7203AC	17	40	12	0.6	0.6	10.4	5.6	36000	53000	43000	63000	75	289	626
7204C	20	47	14	1	1	14.6	8.15	32000	48000	43000	63000	74	252	527
7204AC	20	47	14	1	1	14	7.8	30000	45000	36000	53000	105	393	843
7205C	25	52	15	1	1	15.6	9.3	28000	43000	36000	53000	79	269	562
7205AC	25	52	15	1	1	15	9	26000	40000	32000	48000	113	420	901
7206C	30	62	16	1	1	23.2	14.6	24000	38000	30000	45000	122	412	856
7206AC	30	62	16	1	1	22	14	22000	36000	26000	40000	175	637	1357
7207C	35	72	17	1.1	1.1	25.5	18	20000	34000	26000	40000	136	454	942
7207AC	35	72	17	1.1	1.1	24.5	17	19000	32000	22000	36000	197	714	1521



Model	Main Dimension(mm)					Basic rated load (KN)		Steel ball limit speed (r/min)		Ceramic ball limit speed (r/min)		Preload (N)		
	d	D	B	r	r1	Cr	Cor	Lipid	Oil	Lipid	Oil	Light(A)	Medium(B)	Heavy(C)
7208C	40	80	18	1.1	1.1	32	22.4	18000	30000	24000	38000	176	584	1204
7208AC	40	80	18	1.1	1.1	30.5	21.6	17000	28000	20000	34000	259	912	1925
7209C	45	85	19	1.1	1.1	33.5	24.5	17000	28000	22000	36000	184	607	1252
7209AC	45	85	19	1.1	1.1	32	23.6	15000	24000	18000	30000	270	955	2016
7210C	50	90	20	1.1	1.1	43	31.5	16000	26000	20000	34000	242	792	1631
7210AC	50	90	20	1.1	1.1	40.5	30.5	14000	22000	17000	28000	355	1230	2583
7211C	55	100	21	1.5	1.5	46.5	37.5	14000	22000	18000	30000	261	849	1750
7211AC	55	100	21	1.5	1.5	44	35.5	13000	20000	15000	24000	381	1331	2797
7212C	60	110	22	1.5	1.5	55	44	13000	20000	16000	26000	315	1022	2100
7212AC	60	110	22	1.5	1.5	52	42.5	12000	19000	14000	22000	467	1599	3333
7213C	65	120	23	1.5	1.5	57	48	12000	19000	15000	24000	325	1051	2163
7213AC	65	120	23	1.5	1.5	54	45.5	11000	18000	13000	20000	482	1656	3455
7214C	70	125	24	1.5	1.5	69.5	58.5	11000	18000	14000	22000	404	1301	2664
7214AC	70	125	24	1.5	1.5	65.5	56	10000	17000	12000	19000	600	2030	4233
7215C	75	130	25	1.5	1.5	72	63	11000	18000	14000	22000	416	1346	2757
7215AC	75	130	25	1.5	1.5	68	60	9500	16000	12000	19000	619	2103	4389
7216C	80	140	26	2	2	73.5	68	10000	17000	12000	19000	424	1354	2701
7216AC	80	140	26	2	2	71	64	9000	15000	11000	18000	662	2249	4899
7217C	85	150	28	2	2	96.5	85	9000	15000	11000	18000	573	1825	3734
7217AC	85	150	28	2	2	91.5	80	8000	13000	10000	17000	869	2889	5972
7218C	90	160	30	2	2	122	104	8500	14000	11000	18000	738	2332	4746
7218AC	90	160	30	2	2	116	100	7500	12000	9000	15000	1136	3717	7651
7219C	95	170	32	2.1	2.1	127	114	8000	13000	10000	17000	768	2426	4937
7219AC	95	170	32	2.1	2.1	122	108	7000	11000	8500	14000	1193	3906	8042
7220C	100	180	34	2.1	2.1	132	122	7500	12000	9500	16000	796	2519	5128
7220AC	100	180	34	2.1	2.1	125	116	6700	10000	8000	13000	1217	3994	8229
7221C	105	190	36	2.1	2.1	163	146	7000	11000	9000	15000	997	3140	6377
7221AC	105	190	36	2.1	2.1	156	140	6300	9500	7500	12000	1558	5040	10337
7222C	110	200	38	2.1	2.1	163	150	6700	10000	8500	14000	997	3139	6376
7222AC	110	200	38	2.1	2.1	153	143	6000	9000	7000	11000	1525	4939	10131
7224C	120	215	40	2.1	2.1	204	196	6000	9000	7500	12000	1269	3957	8038
7224AC	120	215	40	2.1	2.1	196	186	5300	8000	6300	9500	2003	6418	13107
7226C	130	230	40	3	3	212	216	5600	8500	7000	11000	1316	4108	8347
7226AC	130	230	40	3	3	204	204	5000	7500	6000	9000	2079	6671	13628

## 718 series (Standard)

Nominal contact Angle  $\alpha = 15^\circ, 25^\circ$   
 Inner diameter 10-150mm



Contact angle	C-15° or AC-25°
Rolling element	Steel ball or ceramic ball
Structure	Open or sealed
Holder	Nylon or bakelite
Precision	P5, P4, P2 level
Pairing	Provide any configuration of SU&GA universal matching level (DT, DB, DF, TBT, etc.)

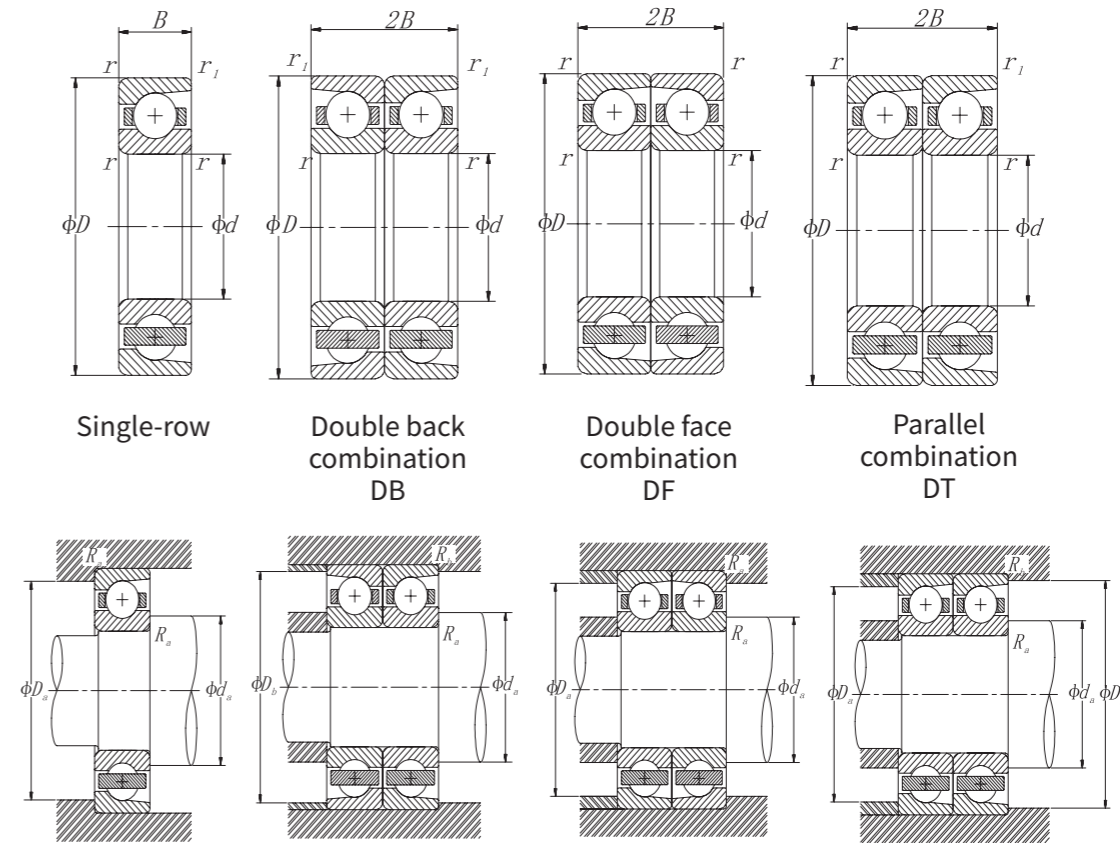

Model	Main Dimension(mm)					Basic rated load (KN)		Steel ball limit speed (r/min)		Ceramic ball limit speed (r/min)		Preload (N)		
	d	D	B	r	r1	Cr	Cor	Lipid	Oil	Lipid	Oil	Light(A)	Medium(B)	Heavy(C)
71800C	10	19	5	0.3	0.1	1.9	0.98	75000	1E+05	95000	160000	7	23	54
71800AC	10	19	5	0.3	0.1	1.9	0.98	70000	1E+05	85000	140000	8	31	80
71801C	12	21	5	0.3	0.1	2.08	1.18	67000	1E+05	85000	140000	7	25	58
71801AC	12	21	5	0.3	0.1	1.96	1.12	60000	90000	75000	120000	8	33	85
71802C	15	24	5	0.3	0.1	2.28	1.5	56000	85000	70000	110000	8	27	63
71802AC	15	24	5	0.3	0.1	2.16	1.4	50000	75000	63000	95000	8	34	91
71803C	17	26	5	0.3	0.1	2.32	1.6	50000	75000	67000	100000	8	26	64
71803AC	17	26	5	0.3	0.1	2.2	1.53	48000	70000	56000	85000	7	33	92
71804C	20	32	7	0.3	0.1	3.8	2.65	43000	63000	53000	80000	15	50	114
71804AC	20	32	7	0.3	0.1	3.65	2.5	38000	56000	45000	67000	18	70	174
71805C	25	37	7	0.3	0.1	4.15	3.2	36000	53000	45000	67000	16	54	123
71805AC	25	37	7	0.3	0.1	3.9	3	32000	48000	38000	56000	18	72	181
71806C	30	42	7	0.3	0.1	4.4	3.65	30000	45000	38000	56000	16	56	129
71806AC	30	42	7	0.3	0.1	4.15	3.4	28000	43000	34000	50000	18	73	189
71807C	35	47	7	0.3	0.1	4.65	4.15	26000	40000	34000	50000	17	58	135
71807AC	35	47	7	0.3	0.1	4.4	3.8	24000	38000	30000	45000	19	76	197

Model	Main Dimension(mm)					Basic rated load (KN)		Steel ball limit speed (r/min)		Ceramic ball limit speed (r/min)		Preload (N)		
	d	D	B	r	r1	Cr	Cor	Lipid	Oil	Lipid	Oil	Light(A)	Medium(B)	Heavy(C)
71808C	40	52	7	0.3	0.1	4.8	4.55	24000	38000	30000	45000	17	59	138
71808AC	40	52	7	0.3	0.1	4.55	4.25	22000	36000	26000	40000	17	75	199
71809C	45	58	7	0.3	0.1	7.2	6.95	22000	36000	28000	43000	22	98	221
71809AC	45	58	7	0.3	0.1	6.8	6.4	19000	32000	24000	38000	35	133	328
71810C	50	65	7	0.3	0.1	7.35	7.35	19000	32000	24000	38000	21	99	224
71810AC	50	65	7	0.3	0.1	6.95	6.8	17000	28000	20000	34000	34	133	332
71811C	55	72	9	0.3	0.1	10.2	10.2	17000	28000	22000	36000	35	147	326
71811AC	55	72	9	0.3	0.1	9.65	9.5	16000	26000	19000	32000	57	206	491
71812C	60	78	10	0.3	0.1	13.2	13.2	16000	26000	20000	34000	51	200	435
71812AC	60	78	10	0.3	0.1	12.2	12.2	14000	22000	17000	28000	80	280	649
71813C	65	85	10	0.6	0.3	13.4	14	15000	24000	19000	32000	51	201	440
71813AC	65	85	10	0.6	0.3	12.7	12.9	13000	20000	16000	26000	82	289	673
71814C	70	90	10	0.6	0.3	14	15	14000	22000	18000	30000	53	210	459
71814AC	70	90	10	0.6	0.3	12.9	13.7	13000	20000	15000	24000	81	289	678
71815C	75	95	10	0.6	0.3	14.3	15.6	13000	20000	16000	26000	53	213	467
71815AC	75	95	10	0.6	0.3	13.4	14.6	12000	19000	14000	22000	84	298	702
71816C	80	100	10	0.6	0.3	14.6	16.6	12000	19000	16000	26000	53	216	474
71816AC	80	100	10	0.6	0.3	13.7	15.6	11000	18000	13000	20000	84	302	712
71817C	85	110	13	1	0.3	21.6	24	11000	18000	14000	22000	93	344	739
71817AC	85	110	13	1	0.3	20.4	22.4	10000	17000	12000	19000	113	507	1142
71818C	90	115	13	1	0.3	21.2	23.6	11000	18000	14000	22000	91	337	724
71818AC	90	115	13	1	0.3	20	22	9500	16000	12000	19000	110	495	1116
71819C	95	120	13	1	0.3	21.6	24.5	10000	17000	13000	20000	92	343	737
71819AC	95	120	13	1	0.3	20.4	22.8	9000	15000	11000	18000	111	504	1137
71820C	100	125	13	1	0.3	21.6	25	9500	16000	12000	19000	91	341	735
71820AC	100	125	13	1	0.3	20.4	23.6	8500	14000	10000	17000	109	500	1132
71821C	105	130	13	1	0.3	22.8	27.5	9000	15000	12000	19000	95	358	774
71821AC	105	130	13	1	0.3	21.6	25.5	8000	13000	10000	17000	112	525	1193
71822C	110	140	16	1	0.3	31.5	36.5	8500	14000	11000	18000	146	521	1105
71822AC	110	140	16	1	0.3	29	34	7500	12000	9000	15000	181	757	1673
71824C	120	150	16	1	0.3	32	39	7500	12000	10000	17000	146	527	1119
71824AC	120	150	16	1	0.3	30	36	7000	11000	8500	14000	184	779	1725
71826C	130	165	18	1.1	0.6	42.5	51	7000	11000	9000	15000	208	723	1523
71826AC	130	165	18	1.1	0.6	40	48	6300	9500	7500	12000	277	1092	2378
71828C	140	175	18	1.1	0.6	43	54	6300	9500	8000	13000	208	728	1536
71828AC	140	175	18	1.1	0.6	40.5	51	6000	9000	7000	11000	275	1097	2397
71830C	150	190	20	1.1	0.6	56	69.5	6000	9000	7500	12000	281	955	1995
71830AC	150	190	20	1.1	0.6	52	64	5300	8000	6300	9500	386	1465	3145



## 719 series (Standard)

Nominal contact Angle  $\alpha = 15^\circ, 25^\circ$   
Inner diameter 10-150mm



Contact angle	C-15° or AC-25°
Rolling element	Steel ball or ceramic ball
Structure	Open or sealed
Holder	Nylon or bakelite
Precision	P5, P4, P2 level
Pairing	Provide any configuration of SU&GA universal matching level (DT, DB, DF, TBT, etc.)

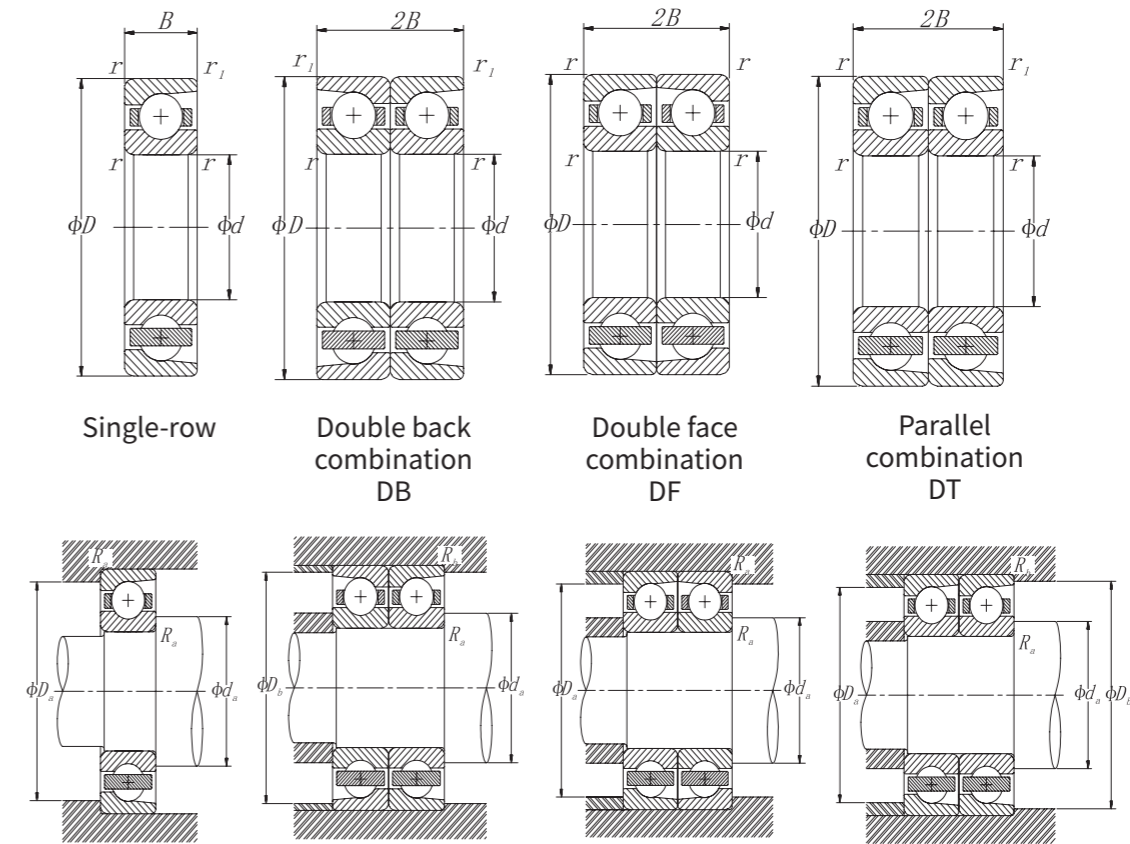

Model	Main Dimension(mm)					Basic rated load (KN)		Steel ball limit speed (r/min)		Ceramic ball limit speed (r/min)		Preload (N)		
	d	D	B	r	r1	Cr	Cor	Lipid	Oil	Lipid	Oil	Light(A)	Medium(B)	Heavy(C)
71900C	10	22	6	0.3	0.1	3	1.53	70000	110000	90000	150000	14	51	114
71900AC	10	22	6	0.3	0.1	2.9	1.46	63000	95000	75000	120000	17	63	149
71901C	12	24	6	0.3	0.3	3.35	1.86	60000	90000	80000	130000	15	56	126
71901AC	12	24	6	0.3	0.3	3.2	1.76	56000	85000	67000	100000	19	67	162
71902C	15	28	7	0.3	0.3	5	2.9	50000	75000	67000	100000	20	77	167
71902AC	15	28	7	0.3	0.3	4.8	2.75	48000	70000	56000	85000	22	112	259
71903C	17	30	7	0.3	0.3	5.3	3.15	48000	70000	60000	90000	21	81	176
71903AC	17	30	7	0.3	0.3	5	3	43000	63000	50000	75000	23	116	268
71904C	20	37	9	0.3	0.3	7.35	4.55	38000	56000	50000	75000	41	137	297
71904AC	20	37	9	0.3	0.3	6.95	4.4	36000	53000	43000	63000	38	172	390
71905C	25	42	9	0.3	0.3	8.15	5.7	32000	48000	43000	63000	40	141	326
71905AC	25	42	9	0.3	0.3	7.8	5.5	30000	45000	36000	53000	40	189	430
71906C	30	47	9	0.3	0.3	8.65	6.55	28000	43000	36000	53000	42	158	345
71906AC	30	47	9	0.3	0.3	8.15	6.3	26000	40000	32000	48000	40	194	445
71907C	35	55	10	0.6	0.6	11.8	9.5	24000	38000	32000	48000	61	209	481
71907AC	35	55	10	0.6	0.6	11	9	22000	36000	26000	40000	61	276	619

Model	Main Dimension(mm)					Basic rated load (KN)		Steel ball limit speed (r/min)		Ceramic ball limit speed (r/min)		Preload (N)		
	d	D	B	r	r1	Cr	Cor	Lipid	Oil	Lipid	Oil	Light(A)	Medium(B)	Heavy(C)
71908C	40	62	12	0.6	0.6	17.6	13.7	22000	36000	28000	43000	85	300	633
71908AC	40	62	12	0.6	0.6	16.6	13.2	20000	34000	24000	38000	112	450	984
71909C	45	68	12	0.6	0.6	18.6	15.6	19000	32000	24000	38000	89	315	667
71909AC	45	68	12	0.6	0.6	17.6	15	18000	30000	22000	36000	116	473	1038
71910C	50	72	12	0.6	0.6	19	16.6	18000	30000	22000	36000	90	321	679
71910AC	50	72	12	0.6	0.6	18	15.6	16000	26000	20000	34000	118	482	1059
71911C	55	80	13	1	1	22.8	20.4	16000	26000	20000	34000	112	391	825
71911AC	55	80	13	1	1	21.6	19.3	15000	24000	18000	30000	149	592	1287
71912C	60	85	13	1	1	24	22.8	15000	24000	19000	32000	117	410	866
71912AC	60	85	13	1	1	22.8	21.6	14000	22000	17000	28000	156	622	1353
71913C	65	90	13	1	1	24.5	24	14000	22000	18000	30000	118	417	883
71913AC	65	90	13	1	1	22.8	22.4	13000	20000	15000	24000	153	617	1348
71914C	70	100	16	1	1	33.5	32.5	13000	20000	16000	26000	172	588	1230
71914AC	70	100	16	1	1	31.5	31	12000	19000	14000	22000	234	890	1917
71915C	75	105	16	1	1	34	34.5	12000	19000	16000	26000	174	596	1246
71915AC	75	105	16	1	1	32	32.5	11000	18000	13000	20000	236	901	1943
71916C	80	110	16	1	1	34.5	36	12000	19000	15000	24000	175	603	1262
71916AC	80	110	16	1	1	32.5	34	11000	18000	13000	20000	238	911	1969
71917C	85	120	18	1.1	1.1	45	46.5	11000	18000	13000	20000	239	804	1672
71917AC	85	120	18	1.1	1.1	42.5	44	9500	16000	12000	19000	336	1232	2631
71918C	90	125	18	1.1	1.1	45.5	49	10000	17000	13000	20000	240	811	1688
71918AC	90	125	18	1.1	1.1	43	46.5	9000	15000	11000	18000	337	1243	2655
71919C	95	130	18	1.1	1.1	46.5	51	9500	16000	12000	19000	245	827	1724
71919AC	95	130	18	1.1	1.1	44	48	8500	14000	10000	17000	343	1269	2713
71920C	100	140	20	1.1	1.1	58.5	64	9000	15000	11000	18000	318	1059	2194
71920AC	100	140	20	1.1	1.1	55	60	8000	13000	9500	16000	453	1626	3437
71921C	105	145	20	1.1	1.1	58.5	64	8500	14000	11000	18000	318	1059	2194
71921AC	105	145	20	1.1	1.1	55	60	7500	12000	9000	15000	453	1626	3437
71922C	110	150	20	1.1	1.1	58.5	67	8000	13000	10000	17000	316	1056	2191
71922AC	110	150	20	1.1	1.1	56	63	7500	12000	9000	15000	458	1651	3495
71924C	120	165	22	1.1	1.1	73.5	85	7000	11000	9000	15000	408	1344	2773
71924AC	120	165	22	1.1	1.1	69.5	80	6700	10000	8000	13000	591	2087	4388
71926C	130	180	24	1.5	1.5	86.5	100	6700	10000	8500	14000	489	1600	3291
71926AC	130	180	24	1.5	1.5	81.5	95	6000	9000	7000	11000	714	2477	5193
71928C	140	190	24	1.5	1.5	90	108	6000	9000	7500	12000	506	1661	3412
71928AC	140	190	24	1.5	1.5	85	102	5600	8500	6700	10000	740	2576	5405
71930C	150	210	28	2	1	122	143	5600	8500	7000	11000	710	2286	4680
71930AC	150	210	28	2	1	114	134	5000	7500	6000	9000	1046	3541	7369

## B70 series (Improved)

Nominal contact Angle  $\alpha = 15^\circ$   
Inner diameter 10-60mm

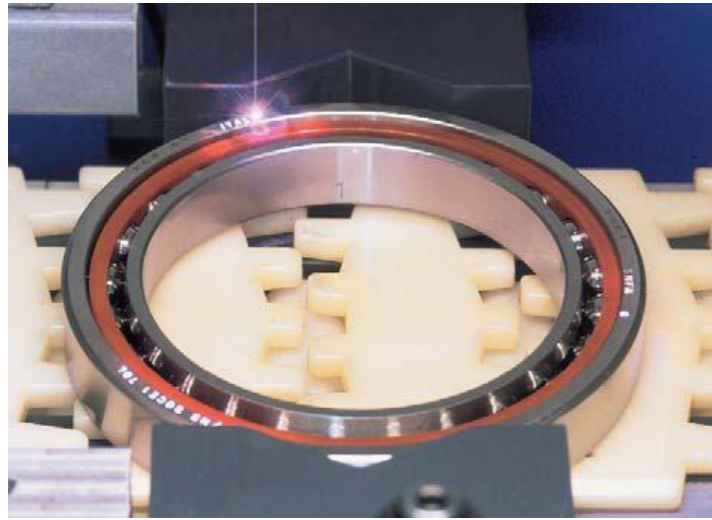

Contact angle	C-15°
Rolling element	Steel ball or ceramic ball
Structure	Open
Holder	bakelite
Precision	P5, P4, P2 level
Pairing	Provide any configuration of SU&GA universal matching level (DT, DB, DF, TBT, etc.)

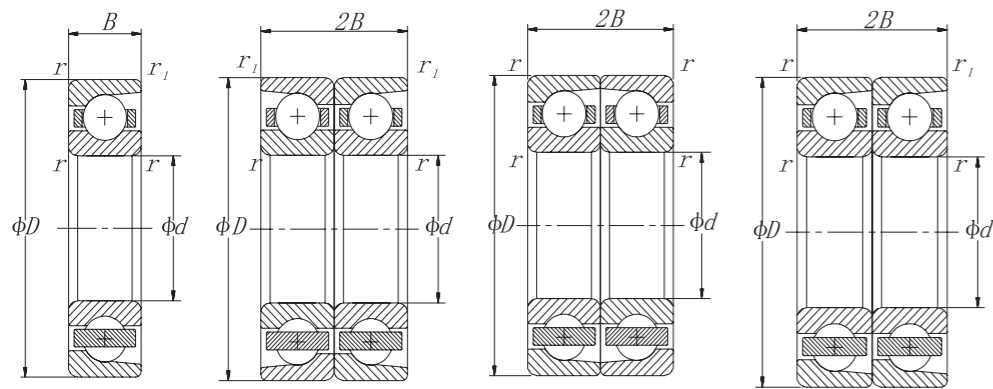

Single-row      Double back combination DB      Double face combination DF      Parallel combination DT

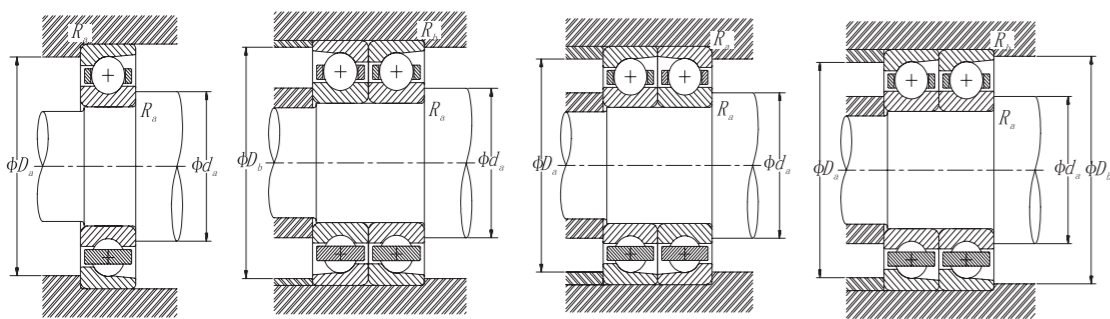

7000 C type  $\alpha = 15^\circ$   
7000 AC type  $\alpha = 25^\circ$   
7000 B type  $\alpha = 40^\circ$

Model	Main Dimension (mm)					Basic rated load (KN)		Limit speed (r/min)		Preload (N)		
	d	D	B	r	r1	Cr	Cor	Lipid	Oil	Light (A)	Medium (B)	Heavy (C)
B7000 C	10	26	8	0.3	0.15	3	1.2	80000	130000	17	67	145
B7000 C HQ1	10	26	8	0.3	0.15	3	1.2	100000	160000	22	100	224
B7001 C	12	28	8	0.3	0.15	3.3	1.3	70000	110000	19	74	161
B7001 C HQ1	12	28	8	0.3	0.15	3.3	1.3	85000	130000	23	110	250
B7002 C	15	32	9	0.3	0.15	3.6	1.6	60000	90000	28	102	216
B7002 C HQ1	15	32	9	0.3	0.15	3.6	1.6	75000	110000	36	154	344
B7003 C	17	35	10	0.3	0.15	3.9	1.7	53000	80000	41	146	308
B7003 C HQ1	17	35	10	0.3	0.15	3.9	1.7	67000	100000	54	221	487
B7004 C	20	42	12	0.6	0.15	5.7	2.7	45000	67000	52	179	377
B7004 C HQ1	20	42	12	0.6	0.15	5.7	2.7	56000	85000	71	277	598
B7005 C	25	47	12	0.6	0.15	7.4	3.8	38000	56000	74	254	533
B7005 C HQ1	25	47	12	0.6	0.15	7.4	3.8	45000	67000	101	384	828
B7006 C	30	55	13	1	0.3	9.1	4.8	32000	48000	75	260	545
B7006 C HQ1	30	55	13	1	0.3	9.1	4.8	38000	56000	102	397	861
B7007 C	35	62	14	1	0.3	10.9	6	28000	43000	97	333	697
B7007 C HQ1	35	62	14	1	0.3	10.9	6	34000	53000	136	518	1116
B7008 C	40	68	15	1	0.3	12.9	7.4	26000	40000	102	353	743
B7008 C HQ1	40	68	15	1	0.3	12.9	7.4	32000	48000	142	547	1180
B7009 C	45	75	16	1	0.3	15	9	24000	38000	145	490	1019
B7009 C HQ1	45	75	16	1	0.3	15	9	30000	45000	209	768	1638
B7010 C	50	80	16	1	0.3	15.9	10	22000	36000	150	507	1054
B7010 C HQ1	50	80	16	1	0.3	15.9	10	26000	43000	211	779	1663
B7011 C	55	90	18	1.1	0.6	19.9	12.9	19000	32000	207	687	1424
B7011 C HQ1	55	90	18	1.1	0.6	19.9	12.9	22000	38000	298	1066	2257
B7012 C	60	95	18	1.1	0.6	20.4	13.6	18000	30000	211	704	1459
B7012 C HQ1	60	95	18	1.1	0.6	20.4	13.6	21000	36000	299	1075	2281



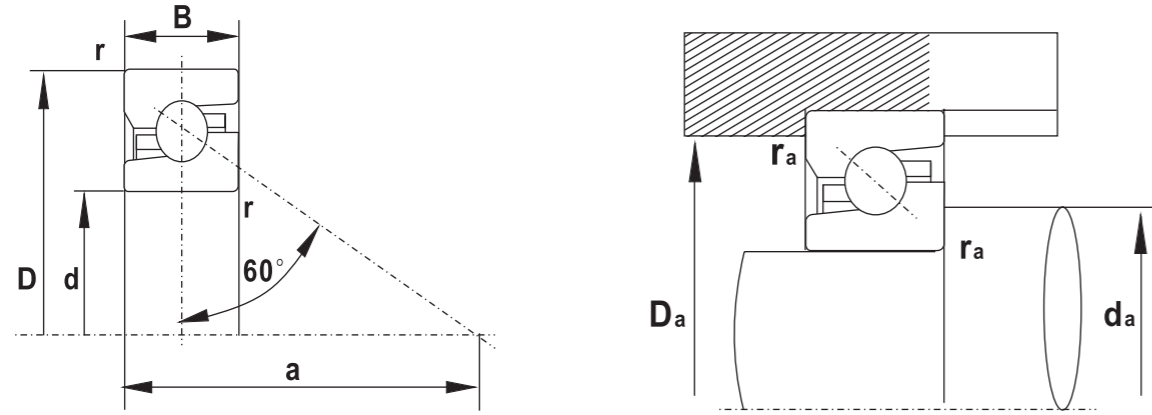

## 760 series

Nominal contact Angle  $\alpha = 60^\circ$   
Inner diameter 12-100mm



Structure	Open or sealed
Holder	Nylon
Precision	P5, P4 level
Pairing	Provide GB universal matching, and any combination

Model	Main Dimension (mm)					Basic rated load(KN)		Grease lubrication limit speed(r/min)	Seal design
	d	D	B	r	r1	Ca	Coa		
7602012	12	32	10	0.6	0.6	12.2	20.7	8000	0
7602015	15	35	11	0.6	0.6	13.1	24.7	6700	0
7602017	17	40	12	0.6	0.6	17.2	32.5	6000	0
7602020	20	47	14	1	1	19.1	38	5000	0
7603020	20	52	15	1.1	1.1	25.5	53	4500	0
7602025	25	52	15	1	1	23.2	50	4500	0
7603025	25	62	17	1.1	1.1	29.5	68	3800	0
7602030	30	62	16	1	1	27.5	66	3800	0
7603030	30	72	19	1.1	1.1	36.5	89	3200	0
7602035	35	72	17	1.1	1.1	31.5	81	3200	0
7603035	35	80	21	1.5	1.5	38	100	3000	0
7602040	40	80	18	1.1	1.1	39	106	2800	0
7603040	40	90	23	1.5	1.5	52	138	2600	0
7602045	45	85	19	1.1	1.1	39.5	111	2600	0
7603045	45	100	25	1.5	1.5	62	172	2200	0
7602050	50	90	20	1.1	1.1	41	122	2400	0
7603050	50	110	27	2	2	72	203	2000	0
7602055	55	100	21	1.5	1.5	42	132	2200	0
7603055	55	120	29	2	2	85	255	1900	0
7602060	60	110	22	1.5	1.5	58	183	2000	0
7603060	60	130	31	2.1	2.1	92	270	1800	0
7602065	65	120	23	1.5	1.5	60	197	1800	0
7603065	65	140	33	2.1	2.1	106	330	1600	0
7602070	70	125	24	1.5	1.5	68	220	1800	0
7603070	70	150	35	2.1	2.1	117	360	1600	0
7602075	75	130	25	1.5	1.5	70	236	1600	0
7603075	75	160	37	2.1	2.1	132	425	1400	0
7602080	80	140	26	2	2	81	275	1500	0
7603080	80	170	39	2.1	2.1	144	465	1400	0
7602085	85	150	28	2	2	95	340	1400	0
7603085	85	180	41	3	3	169	550	1300	0
7602090	90	160	30	2	2	102	365	1300	0
7603090	90	190	43	3	3	172	580	1200	0
7602095	95	170	32	2.1	2.1	116	410	1300	0
7603095	95	200	45	3	3	175	600	1200	0
7602100	100	180	34	2.1	2.1	128	465	1200	0
7603100	100	215	47	3	3	201	700	1100	0

## BSB series

Nominal contact Angle  $\alpha = 60^\circ$   
Inner diameter 15-100mm

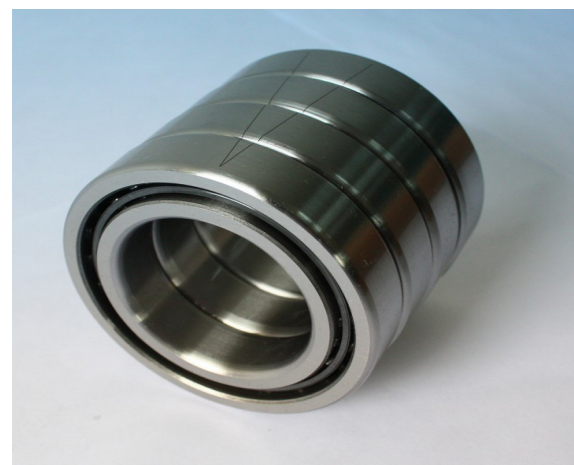

Structure	Open or sealed
Holder	Nylon
Precision	P5, P4 level
Pairing	Provide GB universal matching, and any combination

Model	Main Dimension (mm)					Basic rated load(KN)		Grease lubrication limit speed(r/min)
	d	D	B	r	r1	Ca	Coa	
15TAC47B	15	47	15	1	0.6	20.5	27	12000
17TAC47B	17	47	15	1	0.6	20.8	27	12000
20TAC47B	20	47	15	1	1	20.8	43	5600
25TAC62B	25	62	15	1	1	29.5	68	4300
30TAC62B	30	62	15	1	1	27.5	66	4200
35TAC72B	35	72	15	1	1	31.5	81	3700
40TAC72B	40	72	15	1	1	29.5	82	3500
40TAC90B	40	90	20	1.5	1.5	52	138	3100
45TAC75B	45	75	15	1	1	30	85	3300
45TAC100B	45	100	20	1.5	1.5	62	172	2700
50TAC100B	50	100	20	1.5	1.5	62	172	2700
55TAC90B	55	90	15	1	1	33.5	98	2800
55TAC120B	55	120	20	2	2	63	188	2400
60TAC120B	60	120	20	1.5	1.5	64	196	2300
75TAC110B	75	110	15	1.5	1.5	37	133	2300
100TAC150B	100	150	22.5	2	2	73	265	1800

## TAD series

Nominal contact Angle  $\alpha = 55^\circ$   
Inner diameter 25-120mm

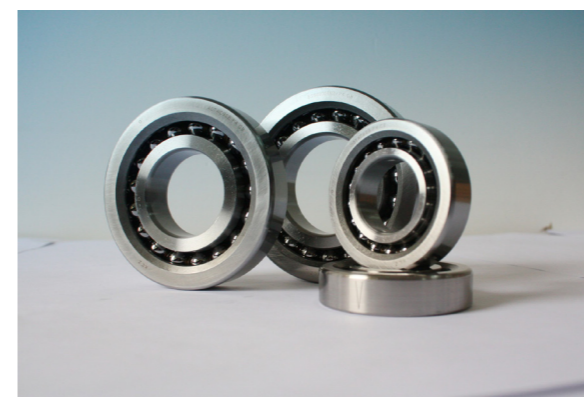

Model	Main Dimension (mm)					Basic rated load(KN)		Limit speed (r/min)	Use reference size (mm)			
	d	D	B	r	r1	Ca	Coa		da1	da2	Da1	Da2
25TAD05A	25	52	15	1.0	0.6	38000	25700	7700	38.7	31.6	39.7	48.0
25TAD06A	25	62	17	1.1	0.6	64500	40500	6800	43.0	32.7	44.5	56.6
30TAD07A	30	72	19	1.1	0.6	78500	56900	5800	50.4	38.8	52.1	65.8
35TAD09A	35	90	23	1.5	1.0	119000	85500	4600	64.3	50.8	66.3	82.2
40TAD09A	40	90	23	1.5	1.0	119000	85500	4600	64.3	60.8	66.3	82.2
40TAD11A	40	110	27	2.0	1.0	173000	131000	3700	79.2	62.4	81.7	101.0
45TAD10A	45	100	25	1.5	1.0	139000	103000	4100	71.8	62.4	74.0	91.1
45TAD11A	45	100	27	2.0	1.0	173000	131000	3700	79.2	56.9	81.7	101.0
50TAD11A	50	110	27	2.0	1.0	173000	131000	3700	79.2	62.4	81.7	101.0
50TAD13A	50	130	31	2.1	1.1	225000	174000	2600	94.1	74.7	96.9	119.5
60TAD13A	60	130	31	2.1	1.1	225000	174000	2600	94.1	74.7	96.9	119.5
60TAD17A	60	170	39	2.1	1.1	315000	280000	2400	123.8	99.3	127.4	155.8
80TAD17A	80	170	39	2.1	1.1	315000	280000	2400	123.8	99.3	127.4	155.8
80TAD21A	80	215	47	3.0	1.1	445000	405000	1900	155.2	125.0	160.5	196.2
100TAD21A	100	215	47	3.0	1.1	445000	405000	1900	155.2	125	160.5	192.2
100TAD26A	100	260	55	3.0	1.1	550000	504000	1500	187.1	153.4	193.3	234.9
120TAD26A	120	260	55	3.0	1.1	550000	504000	1500	187.1	153.4	193.3	234.9

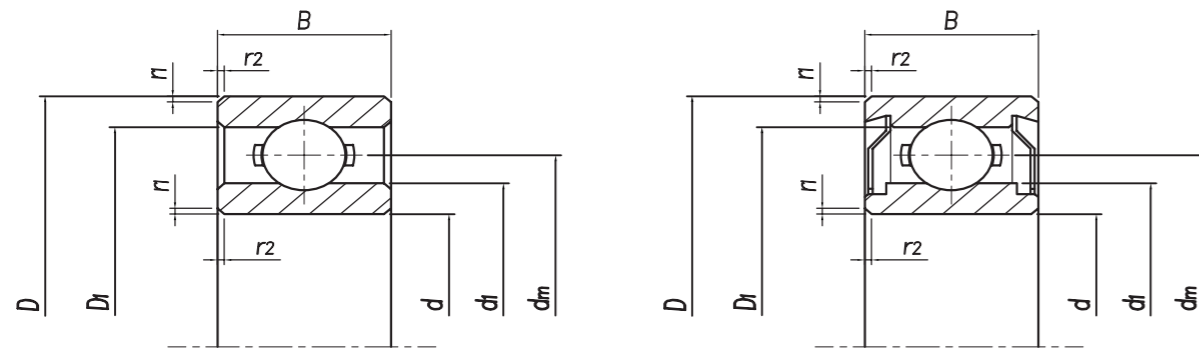

## 60 Series

Inner diameter 9-150mm



Model	Dimension			Ball		Size			Butt size			Weight m	Rated load		Speed data ngrease
	d	D	B	Dw	Z	d1	D1	r1,2	ramax	damin	Damax		C	C0	
609	9	24	7			14.2	19.2	0.3	0.3	11.4	21.6	0.016	3.35	1.40	22000
6000	10	26	8	4.762	7	14.9	21.3	0.3	0.3	12.4	23.6	0.019	4.58	1.98	22000
6001	12	28	8	4.762	8	17.4	23.8	0.3	0.3	14.4	25.6	0.022	5.1	2.38	20000
6002	15	32	9	4.762	9	20.4	26.6	0.3	0.3	17.4	29.6	0.031	5.58	2.85	19000
6003	17	35	10	4.762	10	22.9	29.1	0.3	0.3	19.4	32.6	0.04	6	3.25	17000
6004	20	42	12	6.35	9	26.9	35.1	0.6	0.6	25	38	0.068	9.38	5.02	16000
6005	25	47	12	6.35	10	31.9	40.1	0.6	0.6	30	43	0.078	10	5.85	13000
6006	30	55	13	7.144	11	38.4	47.7	1	1	36	50	0.113	13.2	8.3	11000
6007	35	62	14	8	11	43.3	53.7	1	1	41	56	0.148	16.2	10.50	9500
6008	40	68	15	8	12	48.8	59.2	1	1	46	62	0.185	17	11.8	9000
6009	45	75	16	9	12	54.2	65.9	1	1	51	69	0.23	21	14.8	8000
6010	50	80	16	9	13	59.2	70.9	1	1	56	74	0.25	22	16.2	7000
6011	55	90	18	11	12	65.4	79.7	1.1	1	62	83	0.362	30.2	21.80	7000
6012	60	95	18	11	13	71.4	85.7	1.1	1	67	89	0.385	31.5	24.2	6300
6013	65	100	18	11.112	13	75.3	89.7	1.1	1	72	93	0.41	32	24.8	6000
6014	70	110	20	12.303	13	82	98	1.1	1	77	103	0.575	38.5	30.5	5600
6015	75	115	20	12.303	14	88	104	1.1	1	82	108	0.603	40.2	33.20	5300
6016	80	125	22	13.494	14	95.2	112.8	1.1	1	87	118	0.821	47.5	39.8	5000
6017	85	130	22	14	14	99.4	117.6	1.1	1	92	123	0.848	50.8	42.8	4500
6018	90	140	24	15.081	14	107.2	126.8	1.5	1.5	99	131	1.1	58	49	4300
6019	95	145	24	15.081	14	110.2	129.8	1.5	1.5	104	136	1.15	57.8	50	4000
6020	100	150	24	16	14	114.6	135.4	1.5	1.5	109	141	1.18	64.5	56.2	3800
6021	105	160	26	17	14	121.5	143.6	2	2	115	150	1.52	71.8	63.20	3600
6022	110	170	28	18.256	14	129.1	152.9	2	2	120	160	1.89	81.8	72.8	3400
6024	120	180	28	19	14	137.7	162.4	2	2	130	170	1.99	87.5	79.2	3000
6026	130	200	33	21	14	151.4	178.7	2	2	140	190	3.08	105	96.8	2800
6028	140	210	33	22.225	14	160.6	189.5	2	2	150	200	3.17	116	108	2400
6030	150	225	35	23.812	14	172	203	2.1	2.1	162	213	3.903	132	125	2200

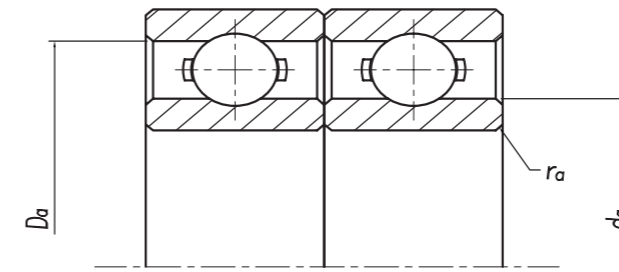

## 62 Series

Inner diameter 15-150mm



Model	Dimension			Ball		Size			Butt size			Weight m	Rated load		Speed data ngrease
	d	D	B	Dw	Z	d1	D1	r1,2	ramax	damin	Damax		C	C0	
6300	10	35	11	6.35	7	19.4	27.6	0.6	0.6	15	30	0.053	7.65	3.48	18000
6301	12	37	12	7.938	6	19.3	29.7	1	1	18	32	0.051	9.72	5.08	17000
6302	15	42	13	7.938	7	24.3	34.7	1	1	21	37	0.08	11.5	5.42	16000
6303	17	47	14	8.731	7	26.8	38.2	1	1	23	41	0.109	13.5	6.58	15000
6304	20	52	15	9.525	7	29.8	42.2	1.1	1	27	45	0.142	15.8	7.88	13000
6305	25	62	17	11.5	7	36	51	1.1	1	32	55	0.219	22.2	11.50	10000
6306	30	72	19	12	8	44.8	59.2	1.1	1	37	65	0.349	27	15.20	9000
6307	35	80	21	13.494	8	50.4	66.6	1.5	1.5	44	71	0.455	33.4	19.20	8000
6308	40	90	23	15.081	8	56.5	74.6	1.5	1.5	49	81	0.639	40.8	24.0	7000
6309	45	100	25	17.462	8	63	84	1.5	1.5	54	91	0.837	52.8	31.8	6300
6310	50	110	27	19.05	8	69.1	91.9	2	2	60	100	1.082	61.8	38	6000
6311	55	120	29	20.638	8	76.1	100.9	2	2	65	110	1.367	71.5	44.8	5600
6312	60	130	31	22.225	8	81.7	108.4	2.1	2.1	72	118	1.71	81.8	51.8	5000
6313	65	140	33	24	8	88.1	116.9	2.1	2.1	77	128	2.1	93.8	60.5	4500
6314	70	150	35	25.4	8	94.8	125.3	2.1	2.1	82	138	2.55	105	68.0	4300
6315	75	160	37	26.988	8	101.3	133.7	2.1	2.1	87	148	3.05	113	77	4000
6316	80	170	39	28.575	8	107.9	142.2	2.1	2.1	92	158	3.61	123	87	3800
6317	85	180	41	30.162	8	114.4	150.6	3	2.5	99	166	4.284	132	96.5	3600
6318	90	190	43	32	8	120.8	159.2	3	2.5	104	176	4.97	145	108.0	3400
6319	95	200	45	34	8	127.1	167.9	3	2.5	109	186	5.74	157	122.0	3200
6320	100	215	47	36.512	8	135.6	179.4	3	2.5	114	201	7.09	173	140.0	2800
6321	105	225	49	38.1	8	142.1	187.9	3	2.5	119	211	8.05	184	153.0	2600
6322	110	240	50	41.275	8	150.2	199.8	3	2.5	124	226	9.53	205	178.0	2400
6324	120	260	55	44.45	8	163.3	216.7	3	2.5	134	246	12.2	228	208	2200
6326	130	280	58	48	8	176.2	233.8	4	3	148	262	14.77	253	242	2000
6328	140	300	62	50.8	8	189.5	250.5	4	3	158	282	18.33	275	272	1900
6330	150	320	65	52.388	8	203.6	266.5	4	3	168	302	21.87	288	295	1700



# 63 Series

Inner diameter 15-150mm



Model	Dimension			Ball		Size			Butt size			Weight m	Rated load		Speed data ngrease
	d	D	B	Dw	Z	d1	D1	r1,2	ramax	damin	Damax		C	C0	
6300	10	35	11	6.35	7	19.4	27.6	0.6	0.6	15	30	0.053	7.65	3.48	18000
6301	12	37	12	7.938	6	19.3	29.7	1	1	18	32	0.051	9.72	5.08	17000
6302	15	42	13	7.938	7	24.3	34.7	1	1	21	37	0.08	11.5	5.42	16000
6303	17	47	14	8.731	7	26.8	38.2	1	1	23	41	0.109	13.5	6.58	15000
6304	20	52	15	9.525	7	29.8	42.2	1.1	1	27	45	0.142	15.8	7.88	13000
6305	25	62	17	11.5	7	36	51	1.1	1	32	55	0.219	22.2	11.50	10000
6306	30	72	19	12	8	44.8	59.2	1.1	1	37	65	0.349	27	15.20	9000
6307	35	80	21	13.494	8	50.4	66.6	1.5	1.5	44	71	0.455	33.4	19.20	8000
6308	40	90	23	15.081	8	56.5	74.6	1.5	1.5	49	81	0.639	40.8	24.0	7000
6309	45	100	25	17.462	8	63	84	1.5	1.5	54	91	0.837	52.8	31.8	6300
6310	50	110	27	19.05	8	69.1	91.9	2	2	60	100	1.082	61.8	38	6000
6311	55	120	29	20.638	8	76.1	100.9	2	2	65	110	1.367	71.5	44.8	5600
6312	60	130	31	22.225	8	81.7	108.4	2.1	2.1	72	118	1.71	81.8	51.8	5000
6313	65	140	33	24	8	88.1	116.9	2.1	2.1	77	128	2.1	93.8	60.5	4500
6314	70	150	35	25.4	8	94.8	125.3	2.1	2.1	82	138	2.55	105	68.0	4300
6315	75	160	37	26.988	8	101.3	133.7	2.1	2.1	87	148	3.05	113	77	4000
6316	80	170	39	28.575	8	107.9	142.2	2.1	2.1	92	158	3.61	123	87	3800
6317	85	180	41	30.162	8	114.4	150.6	3	2.5	99	166	4.284	132	96.5	3600
6318	90	190	43	32	8	120.8	159.2	3	2.5	104	176	4.97	145	108.0	3400
6319	95	200	45	34	8	127.1	167.9	3	2.5	109	186	5.74	157	122.0	3200
6320	100	215	47	36.512	8	135.6	179.4	3	2.5	114	201	7.09	173	140.0	2800
6321	105	225	49	38.1	8	142.1	187.9	3	2.5	119	211	8.05	184	153.0	2600
6322	110	240	50	41.275	8	150.2	199.8	3	2.5	124	226	9.53	205	178.0	2400
6324	120	260	55	44.45	8	163.3	216.7	3	2.5	134	246	12.2	228	208	2200
6326	130	280	58	48	8	176.2	233.8	4	3	148	262	14.77	253	242	2000
6328	140	300	62	50.8	8	189.5	250.5	4	3	158	282	18.33	275	272	1900
6330	150	320	65	52.388	8	203.6	266.5	4	3	168	302	21.87	288	295	1700

# 160 Series

Inner diameter 12-150mm



Model	Dimension			Ball		Size			Butt size			Weight m	Rated load		Speed data ngrease
	d	D	B	Dw	Z	d1	D1	r1,2	ramax	damin	Damax		C	C0	
16001	12	28	7	4.762	8	16.7	23.3	0.3	0.3	14.4	25.6	0.02	5.1	2.4	20000
16002	15	32	8	4.762	9	20.2	26.8	0.3	0.3	17.4	29.6	0.02	5.6	2.8	19000
16003	17	35	8	4.762	10	22.7	29.3	0.3	0.3	19.4	32.6	0.03	6	3.3	18000
16004	20	42	8	5.556	10	27.1	34.9	0.3	0.3	22.4	39.6	0.05	7.9	4.5	16000
16005	25	47	8	5.556	12	33.1	40.9	0.3	0.3	27.4	44.6	0.06	8.8	5.6	13000
16006	30	55	9	6.35	12	38.1	47	0.3	0.3	32.4	52.6	0.08	11.2	7.4	11000
16007	35	62	9	6.35	14	44.6	53.5	0.3	0.3	37.4	59.6	0.11	12.2	8.8	9500
16008	40	68	9	6.35	15	49.6	58.5	0.3	0.3	42.4	65.6	0.13	12.6	9.6	9000
16009	45	75	10	7.144	15	55	65	0.6	0.6	50	70	0.16	15.6	12.2	8000
16010	50	80	10	7.144	16	60	70	0.6	0.6	55	75	0.17	16.1	13.1	8000
16011	55	90	11	7.938	16	67.3	77.7	0.6	0.6	60	85	0.21	19.4	16.2	7000
16012	60	95	11	7.938	17	72.3	82.7	0.6	0.6	65	90	0.22	19.9	17.5	6300
16013	65	100	11	7.938	18	77.3	87.7	0.6	0.6	70	95	0.24	20.5	18.6	6000
16014	70	110	13	9.525	17	83.8	96.2	0.6	0.6	75	105	0.39	27.9	25	5600
16015	75	115	13	9.525	18	88.8	101	0.6	0.6	80	110	0.41	28.7	26.8	5300
16016	80	125	14	10.32	18	95.8	109	0.6	0.6	85	120	0.54	33.1	31.4	5000
16017	85	130	14	10.32	19	101	114	0.6	0.6	90	125	0.57	34	33.3	4500
16018	90	140	16	11.91	17	107	123	1	1	96	134	0.67	41.5	39.3	4300
16019	95	145	16	11.91	18	112	128	1	1	101	139	0.71	42.7	41.9	4000
16020	100	150	16	11.91	19	118	134	1	1	106	144	0.74	43.8	44.3	3800
16021	105	160	18	13.49	17	124	141	1	1	111	154	1	51.8	50.6	3600
16022	110	170	19	14.29	17	131	149	1	1	116	164	1.27	57.4	56.7	3400
16024	120	180	19	14.29	18	141	159	1	1	126	174	1.37	58.8	60.4	3000
16026	130	200	22	17.46	16	154	176	1.1	1	137	193	1.87	79.7	79.2	2800
16028	140	210	22	17.46	17	164	186	1.1	1	147	203	2	82.1	85	2400
16030	150	225	24	18.26	18	176	199	1.1	1	157	218	2.64	91.9	98.5	2200

# 618 Series

Inner diameter 10-150mm



Model	Dimension			Ball		Size			Butt size			Weight m	Rated load		Speed data ngrease
	d	D	B	Dw	Z	d1	D1	r1,2	ramax	damin	Damax		C	C0	
61800	10	19	5	2.381	11	12.6	16.4	0.3	0.3	12	17	0.01	1.8	0.93	28000
61801	12	21	5	2.381	12	14.6	18.4	0.3	0.3	14	19	0.01	1.9	1	24000
61802	15	24	5	2.381	14	17.6	21.4	0.3	0.3	17	22	0.01	2.1	1.3	22000
61803	17	26	5	2.381	16	19.6	23.4	0.3	0.3	19	24	0.01	2.2	1.5	20000
61804	20	32	7	3.175	14	23.5	28.6	0.3	0.3	22.4	30	0.02	3.5	2.2	18000
61805	25	37	7	3.5	15	28.2	33.8	0.3	0.3	27.4	35	0.02	4.3	2.9	16000
61806	30	42	7	3.5	18	33.2	38.8	0.3	0.3	32.4	40	0.02	4.7	3.6	13000
61807	35	47	7	3.5	20	38.2	43.8	0.3	0.3	37.4	45	0.02	4.9	4	11000
61808	40	52	7	3.5	22	43.2	48.8	0.3	0.3	42.4	50	0.03	5.1	4.4	10000
61809	45	58	7	3.969	22	48.3	54.7	0.3	0.3	47.4	56	0.03	6.4	5.6	9000
61810	50	65	7	3.969	24	54.3	60.7	0.3	0.3	52.4	62.6	0.04	6.6	6.1	8500
61811	55	72	9	4.762	23	60.2	66.9	0.3	0.3	57.4	69.6	0.07	9.1	8.4	8000
61812	60	78	10	4.762	24	66.2	72.9	0.3	0.3	62.4	75.6	0.09	9.1	8.7	7000
61813	65	85	10	5.556	23	71.1	78.9	0.6	0.6	69	81	0.13	11.9	11.5	6700
61814	70	90	10	5.556	24	76.1	83.9	0.6	0.6	74	86	0.14	12.1	11.9	6300
61815	75	95	10	5.556	26	81.1	88.9	0.6	0.6	79	91	0.15	12.5	12.8	6000
61816	80	100	10	5.556	27	86.1	93.9	0.6	0.6	84	96	0.16	12.7	13.3	5600
61817	85	110	13	7.144	24	92.5	103	1	1	90	105	0.25	19.2	19.8	5000
61818	90	115	13	7.144	25	97.5	108	1	1	95	110	0.26	19.5	20.5	4800
61819	95	120	13	7.144	26	103	113	1	1	100	115	0.27	19.8	21.3	4500
61820	100	125	13	7.144	27	108	118	1	1	105	120	0.28	20.1	22	4300
61821	105	130	13	7.144	28	113	123	1	1	110	125	0.3	20.3	22.7	4000
61822	110	140	16	8.731	25	119	131	1	1	115	135	0.5	28.1	30.7	3800
61824	120	150	16	8.731	27	129	141	1	1	125	145	0.54	28.9	32.9	3400
61826	130	165	18	10.32	25	141	154	1.1	1	137	158	0.74	37.9	42.9	3200
61828	140	175	18	10.32	26	151	164	1.1	1	147	168	0.78	38.2	44.3	3000
61830	150	190	20	11.91	25	162	178	1.1	1	157	183	1.11	49.1	57.1	2800

# 619 Series

Inner diameter 12-150mm



Model	Dimension			Ball		Size			Butt size			Weight m	Rated load		Speed data ngrease
	d	D	B	Dw	Z	d1	D1	r1,2	ramax	damin	Damax		C	C0	
619/9	9	20	6			12	17	0.3	0.3	11.4	18.2	0.01	2.48	1.08	27000
61900	10	22	6	3.175	9	13.5	18.5	0.3	0.3	12.4	20	0.01	2.7	1.3	25000
61901	12	24	6	3.175	10	15.5	20.6	0.3	0.3	14.4	22	0.01	2.9	1.5	22000
61902	15	28	7	3.969	10	18.3	24.7	0.3	0.3	17.4	26	0.01	4.3	2.3	20000
61903	17	30	7	3.969	11	20.3	26.7	0.3	0.3	19.4	28	0.01	4.6	2.6	19000
61904	20	37	9	4.762	11	25.2	31.8	0.3	0.3	22.4	34.6	0.03	6.4	3.7	17000
61905	25	42	9	4.762	13	30.2	36.8	0.3	0.3	27.4	40	0.04	7	4.5	14000
61906	30	47	9	4.762	14	35.2	41.8	0.3	0.3	32.4	44.6	0.04	7.2	5	12000
61907	35	55	10	5.556	14	41.1	48.9	0.6	0.6	40	51	0.08	9.5	6.8	10000
61908	40	62	12	6.747	14	46.3	55.7	0.6	0.6	45	58	0.1	13.7	9.9	9500
61909	45	68	12	6.747	15	51.8	61.2	0.6	0.6	50	63	0.12	14.1	10.9	8500
61910	50	72	12	6.747	16	56.3	65.7	0.6	0.6	55	68	0.12	14.5	11.7	8000
61911	55	80	13	7.144	16	62.9	72.2	1	1	61	75	0.17	15.9	13.2	7500
61912	60	85	13	7.144	17	67.9	77.2	1	1	66	80	0.18	16.4	14.2	6700
61913	65	91	13	7.144	19	72.9	82.2	1	1	71	85	0.2	17.4	16	6300
61914	70	100	16	8.731	17	79.3	90.7	1	1	76	95	0.34	23.7	21.1	6000
61915	75	105	16	8.731	18	84.3	95.7	1	1	81	100	0.36	24.3	22.5	5600
61916	80	110	16	8.731	19	89.3	101	1	1	86	105	0.38	24.9	23.9	5300
61917	85	120	18	10.32	17	95.8	109	1.1	1	92	113.5	0.51	31.9	29.7	4800
61918	90	125	18	10.32	18	101	114	1.1	1	97	118.5	0.53	32.8	31.5	4500
61919	95	130	18	10.32	19	106	119	1.1	1	102	124	0.56	33.7	33.3	4300
61920	100	140	20	11.91	18	112	128	1.1	1	107	133	0.77	42.7	41.9	4000
61921	105	145	20	11.91	19	117	133	1.1	1	112	138	0.81	43.9	44.3	3800
61922	110	150	20	11.91	19	122	138	1.1	1	117	143	0.84	43.6	44.4	3600
61924	120	165	22	13.49	19	134	151	1.1	1	127	158	1.13	55	56.9	3200
61926	130	180	24	15.08	18	145	165	1.5	1.5	139	171	1.5	65.1	67.2	3000
61928	140	190	24	15.08	19	155	175	1.5	1.5	149	181	1.59	66.6	71.2	2800
61930	150	210	28	17.46	18	169	191	2	2	160	180	2.45	84.7	90.2	2600



## SCREW TECHNOLOGY CO.,LTD.

Add: 5/F, Bldg. B, Baodai Sci-Tech Park, 988 Wusong Road,Wuzhong Dist.,  
Suzhou, Jiangsu,China (215124)

Tel: +86-0512-66903936

Mobile: +86-19522756236

Mail: [IMD@screwtech.cn](mailto:IMD@screwtech.cn)

Web: [www.screw-tech.com](http://www.screw-tech.com)

V-1.1.1  
20210129