

# Coupling



**SCREWTECH**  
斯科勒自动化

# CONTENTS

<http://www.screw-tech.com/>



**SCREWTECH**  
斯科勒自动化

2	CONTENTS
3	JWC-CE
4	JWC-CR
5	JWC-CZ
6	JWC-SE
7	JWC-SR
8	DKD-CE
9	DKD-CR
10	DKS-CE
11	DKS-CR
12	BMCH-CE
13	BMCH-SE
14	BMCP-CR
15	BMCP-SR
16	DKD-KS
17	DKS-KS
18	DKD-ZE
19	DKS-ZE
20	OHC-C
21	OHC-S
22	BLC-C-
23	BLC-S-
24	RGL-CE
25	RGS-CE

## Jaw Type Flexible Coupling “JWC-CE” Series (Clamp Type) (Bores: 2-60 mm)



### Features:

- Coupling assembled by pressing a polyurethane sleeve into hubs on both sides.
- Can absorb vibration, parallel & angular misalignments and shaft end-play.
- Identical clockwise and anticlockwise rotational characteristic
- Resistance to oil and electrical insulation.
- Clamp type.

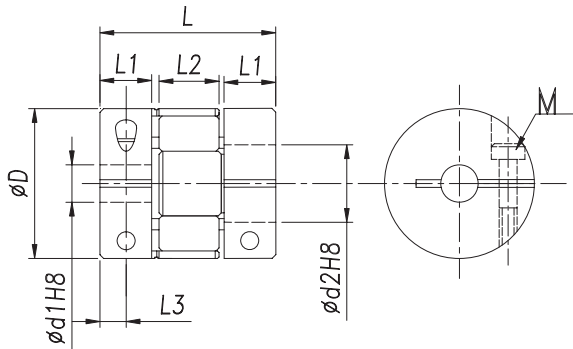

Material		Accessories
Body	Sleeve	
Aluminum Alloy	PU	Clamp Screw

### Dimensions

Code	D	d1/d2	L	L1	L2	L3	Clamp Screw	
	mm	mm	mm	mm	mm	mm	Thread	Wrench Torque(N•m)
JWC14CE	14	2 ~ 7	22	7	6	3.5	M2.5	1.0
JWC20CE	20	4 ~ 10	30	10	8	5.0	M3	1.3
JWC25CE	25	4 ~ 12	34	11	10	5.0	M4	1.5
JWC30CE	30	8 ~ 16	35	11	10	5.0	M4	1.7
JWC40CE	40	14 ~ 24	66	25	12	10	M6	8.0
JWC55CE	55	14 ~ 28	78	30	14	10.5	M6	8.0
JWC65CE	65	19 ~ 38	90	35	15	11.5	M8	15
JWC80CE	80	24 ~ 45	114	45	18	15.5	M8	15
JWC95CE	95	30 ~ 55	126	50	20	18	M10	25
JWC105CE	105	35 ~ 60	140	56	21	21	M12	35

### Technical Properties

Code	Rated Torque	Max. Torque	Max. Speed	Moment of Inertia	Static Torsional Stiffness	Errors of Eccentricity	Errors of Angularity	Errors of Shaft End-Play	Mass
	N•m	N•m	rpm	Kg•m <sup>2</sup>	N•m/rad	mm	°	mm	g
JWC14CE	1.1	2.2	19000	5.9x10 <sup>-4</sup>	46	0.02	1.0	+0.60	26
JWC20CE	2.8	5.6	17000	6.5x10 <sup>-4</sup>	55	0.02	1.0	+0.60	37
JWC25CE	6.0	12	16000	7.6x10 <sup>-4</sup>	63	0.02	1.0	+0.60	42
JWC30CE	6.5	13	12000	8.5x10 <sup>-4</sup>	72	0.02	1.0	+0.60	50
JWC40CE	32	64	10000	1.1x10 <sup>-3</sup>	550	0.02	1.0	+0.60	156
JWC55CE	46	92	8000	4.4x10 <sup>-3</sup>	1500	0.02	1.0	+0.60	362
JWC65CE	109	218	6000	9.0x10 <sup>-3</sup>	2800	0.02	1.0	+0.60	582
JWC80CE	135	270	4600	1.8x10 <sup>-2</sup>	3500	0.02	1.0	+0.60	966
JWC95CE	260	520	3800	2.0x10 <sup>-2</sup>	4600	0.02	1.0	+0.60	1820
JWC105CE	430	860	3400	3.2x10 <sup>-2</sup>	5800	0.02	1.0	+0.60	2430

\*Note: Inertia moment and the weight are calculated as per the maximum aperture. If you need other dimensions, please feel free to contact us.

## Jaw Type Flexible Coupling “JWC-CR” Series (Clamp Type) (Bores: 2-60 mm)

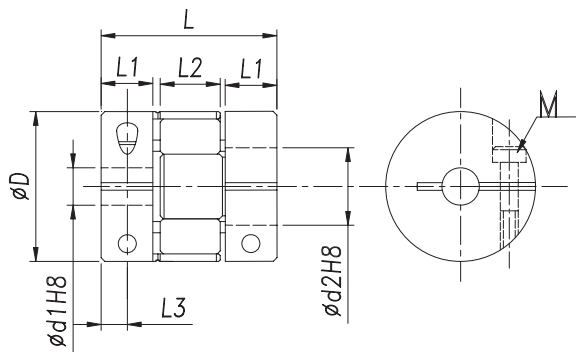

### Features:

- Coupling assembled by pressing a polyurethane sleeve into hubs on both sides.
- Can absorb vibration, parallel & angular misalignments, and shaft end-play.
- Identical clockwise and anticlockwise rotational characteristic.
- Resistance to oil and electrical insulation.
- Clamp type.

Material		Accessories
Body	Sleeve	
Aluminum Alloy	PU	Clamp Screw

## Dimensions

Code	D	d1/d2	L	L1	L2	L3	Clamp Screw	
	mm	mm	mm	mm	mm	mm	Thread	Wrench Torque(N•m)
JWC14CR	14	2 ~ 7	22	7	6	3.5	M2.5	1
JWC20CR	20	4 ~ 10	30	10	8	5.0	M3	1.3
JWC25CR	25	4 ~ 12	34	11	10	5.0	M4	1.5
JWC30CR	30	8 ~ 16	35	11	10	5.0	M4	1.7
JWC40CR	40	14 ~ 24	66	25	12	10	M6	8.0
JWC55CR	55	14 ~ 28	78	30	14	10.5	M6	8.0
JWC65CR	65	19 ~ 38	90	35	15	11.5	M8	15
JWC80CR	80	24 ~ 45	114	45	18	15.5	M8	15
JWC95CR	95	30 ~ 55	126	50	20	18	M10	25
JWC105CR	105	35 ~ 60	140	56	21	21	M12	35

## Technical Properties

Code	Rated Torque	Max. Torque	Max. Speed	Moment of Inertia	Static Torsional Stiffness	Errors of Eccentricity	Errors of Angularity	Errors of Shaft End-Play	Mass
	N•m	N•m	rpm	Kg•m <sup>2</sup>	N•m/rad	mm	°	mm	g
JWC14CR	1.1	2.2	19000	5.9x10 <sup>-4</sup>	46	0.02	1.0	+0.60	26
JWC20CR	2.8	5.6	17000	6.5x10 <sup>-4</sup>	55	0.02	1.0	+0.60	37
JWC25CR	6.0	12	16000	7.6x10 <sup>-4</sup>	63	0.02	1.0	+0.60	42
JWC30CR	6.5	13	12000	8.5x10 <sup>-4</sup>	72	0.02	1.0	+0.60	50
JWC40CR	32	64	10000	1.1x10 <sup>-3</sup>	550	0.02	1.0	+0.60	156
JWC55CR	46	92	8000	4.4x10 <sup>-3</sup>	1500	0.02	1.0	+0.60	362
JWC65CR	109	218	6000	9.0x10 <sup>-3</sup>	2800	0.02	1.0	+0.60	582
JWC80CR	135	270	4600	1.8x10 <sup>-2</sup>	3500	0.02	1.0	+0.60	966
JWC95CR	260	520	3800	2.0x10 <sup>-2</sup>	4600	0.02	1.0	+0.60	1820
JWC105CR	430	860	3400	3.2x10 <sup>-2</sup>	5800	0.02	1.0	+0.60	2430

※Note: Inertia moment and the weight are calculated as per the maximum aperture.If you need other dimensions, please feel free to contact us.

## Jaw Type Flexible Coupling “JWC-CZ” Series (Locking Assemblies) (Bores: 8-60 mm)



### Features:

- Using locking assemblies for connecting, curved jaw type flexible coupling.
- Zero backlash.
- Excellent response and high torque capacity.
- Identical clockwise and anticlockwise rotational characteristic.
- Can absorb vibration, parallel & angular misalignments, and shaft end-play.
- For servo motor, step motor connect.

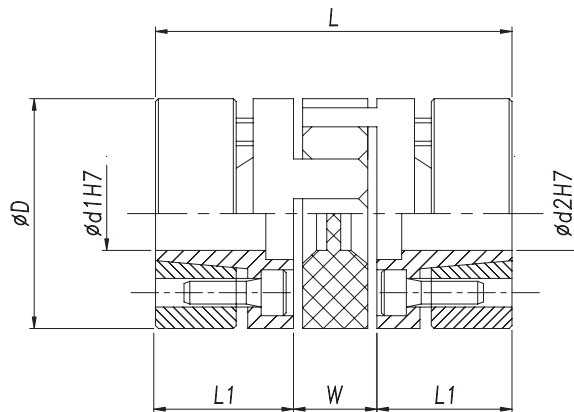

### Dimensions

Code	D	d1/d2	L	L1	Clamp Screw	
	mm	mm	mm	mm	Thread	Wrench Torque (N•m)
JWC35CZ	35	8 ~ 14	50	18.5	M3(4)	1.3
JWC40CZ	40	11 ~ 20	66	25.0	M4(6)	2.7
JWC55CZ	55	14 ~ 28	78	30.0	M5(4)	6.0
JWC65CZ	65	19 ~ 38	90	35.0	M5(8)	6.0
JWC85CZ	85	24 ~ 45	114	45.0	M6(8)	10
JWC95CZ	95	30 ~ 50	126	50.0	M8(4)	35
JWC105CZ	105	35 ~ 60	140	56.0	M8(4)	35

### Technical Properties

Code	Rated Torque	Max. Torque	Max. Speed	Moment of Inertia	Static Torsional Stiffness	Errors of Eccentricity	Errors of Angularity	Errors of Shaft End-Play	Mass
	N•m	N•m	rpm	Kg•m <sup>2</sup>	N•m/rad	mm	°	mm	g
JWC35CZ	7.4	14.8	20000	8.7x10 <sup>-4</sup>	510	0.02	1.0	+0.60	50
JWC40CZ	9.5	19	15000	1.12x10 <sup>-3</sup>	550	0.02	1.0	+0.80	120
JWC55CZ	34	68	13000	4.5x10 <sup>-3</sup>	1510	0.02	1.0	+0.80	280
JWC65CZ	95	190	10500	9.2x10 <sup>-3</sup>	2800	0.02	1.0	+0.80	450
JWC85CZ	135	270	8600	1.9x10 <sup>-2</sup>	3600	0.02	1.0	+1.0	960
JWC95CZ	230	460	7500	2.2x10 <sup>-2</sup>	4700	0.02	1.0	+1.0	2310
JWC105CZ	380	760	6000	3.3x10 <sup>-2</sup>	5800	0.02	1.0	+1.0	3090

※Note: Inertia moment and the weight are calculated as per the maximum aperture. If you need other dimensions, please feel free to contact us.

## Jaw Type Flexible Coupling “JWC-SE” Series (Set Screw) (Bores: 2-60 mm)



**Features:**

- Coupling assembled by pressing a polyurethane sleeve into hubs on both sides.
- Can absorb vibration, parallel & angular misalignments and shaft end-play.
- Identical clockwise and anticlockwise rotational characteristic.
- Resistance to oil and electrical insulation.
- Set Screw type.

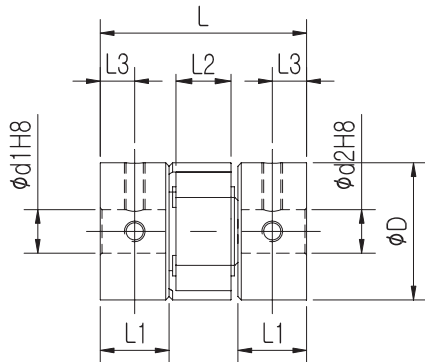

Material		Accessories
Body	Sleeve	
Aluminum Alloy	PU	Set Screw

### Dimensions

Code	D	d1/d2	L	L1	L2	L3	Clamp Screw	
	mm	mm	mm	mm	mm	mm	Thread	Wrench Torque(N•m)
JWC14SE	14	2 ~ 7	22	7	6	3.5	M3	1
JWC20SE	20	4 ~ 10	30	10	8	5.0	M4	1.3
JWC25SE	25	4 ~ 12	34	11	10	5.0	M4	1.5
JWC30SE	30	8 ~ 16	35	11	10	5.0	M4	1.7
JWC40SE	40	14 ~ 24	66	25	12	10	M5	4.0
JWC55SE	55	14 ~ 28	78	30	14	10	M5	4.0
JWC65SE	65	19 ~ 38	90	35	15	15	M8	15
JWC80SE	80	24 ~ 45	114	45	18	15	M8	15
JWC95SE	95	30 ~ 55	126	50	20	20	M8	15
JWC105SE	105	35 ~ 60	140	56	21	20	M8	15

### Technical Properties

Code	Rated Torque	Max. Torque	Max. Speed	Moment of Inertia	Static Torsional Stiffness	Errors of Eccentricity	Errors of Angularity	Errors of Shaft End-Play	Mass
	N•m	N•m	rpm	Kg•m <sup>2</sup>	N•m/rad	mm	°	mm	g
JWC14SE	1.1	2.2	19000	5.9x10 <sup>-4</sup>	46	0.02	1.0	+0.60	26
JWC20SE	2.8	5.6	17000	6.5x10 <sup>-4</sup>	55	0.02	1.0	+0.60	37
JWC25SE	6.0	12	16000	7.6x10 <sup>-4</sup>	63	0.02	1.0	+0.60	42
JWC30SE	6.5	13	15000	8.5x10 <sup>-4</sup>	72	0.02	1.0	+0.60	46
JWC40SE	32	64	13000	1.1x10 <sup>-3</sup>	550	0.02	1.0	+0.60	148
JWC55SE	46	92	10500	4.4x10 <sup>-3</sup>	1500	0.02	1.0	+0.60	350
JWC65SE	109	218	8300	9.0x10 <sup>-3</sup>	2800	0.02	1.0	+0.60	572
JWC80SE	135	270	7000	1.8x10 <sup>-2</sup>	3500	0.02	1.0	+0.60	950
JWC95SE	260	520	6000	2.0x10 <sup>-2</sup>	4600	0.02	1.0	+0.60	1800
JWC105SE	430	860	5500	3.2x10 <sup>-2</sup>	5800	0.02	1.0	+0.60	2400

※Note: Inertia moment and the weight are calculated as per the maximum aperture.If you need other dimensions, please feel free to contact us.

## Jaw Type Flexible Coupling “JWC-SR” Series (Set Screw) (Bores: 2-60 mm)



### Features:

- Coupling assembled by pressing a polyurethane sleeve into hubs on both sides.
- Can absorb vibration, parallel & angular misalignments, and shaft end-play.
- Identical clockwise and anticlockwise rotational characteristic.
- Resistance to oil and electrical insulation.
- Set Screw type

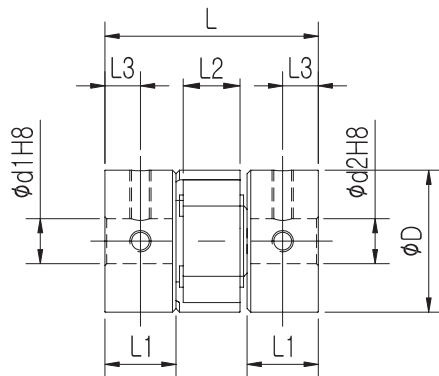

Material		Accessories
Body	Sleeve	
Aluminum Alloy	PU	Set Screw

### Dimensions

Code	D	d1/d2	L	L1	L2	L3	Clamp Screw	
	mm	mm	mm	mm	mm	mm	Thread	Wrench Torque(N•m)
JWC14SR	14	2 ~ 7	22	7	6	3.5	M3	1
JWC20SR	20	4 ~ 10	30	10	8	5.0	M4	1.3
JWC25SR	25	4 ~ 12	34	11	10	5.0	M4	1.5
JWC30SR	30	8 ~ 16	35	11	10	5.0	M4	1.7
JWC40SR	40	14 ~ 24	66	25	12	10	M5	4.0
JWC55SR	55	14 ~ 28	78	30	14	10	M5	4.0
JWC65SR	65	19 ~ 38	90	35	15	15	M8	15
JWC80SR	80	24 ~ 45	114	45	18	15	M8	15
JWC95SR	95	30 ~ 55	126	50	20	20	M8	15
JWC105SR	105	35 ~ 60	140	56	21	20	M8	15

### Technical Properties

Code	Rated Torque	Max. Torque	Max. Speed	Moment of Inertia	Static Torsional Stiffness	Errors of Eccentricity	Errors of Angularity	Errors of Shaft End-Play	Mass
	N•m	N•m	rpm	Kg•m <sup>2</sup>	N•m/rad	mm	°	mm	g
JWC14SR	1.1	2.2	19000	5.9x10 <sup>-4</sup>	46	0.02	1.0	+0.60	26
JWC20SR	2.8	5.6	17000	6.5x10 <sup>-4</sup>	55	0.02	1.0	+0.60	37
JWC25SR	6.0	12	16000	7.6x10 <sup>-4</sup>	63	0.02	1.0	+0.60	42
JWC30SR	6.5	13	15000	8.5x10 <sup>-4</sup>	72	0.02	1.0	+0.60	46
JWC40SR	32	64	13000	1.1x10 <sup>-3</sup>	550	0.02	1.0	+0.60	148
JWC55SR	46	92	10500	4.4x10 <sup>-3</sup>	1500	0.02	1.0	+0.60	350
JWC65SR	109	218	8300	9.0x10 <sup>-3</sup>	2800	0.02	1.0	+0.60	572
JWC80SR	135	270	7000	1.8x10 <sup>-2</sup>	3500	0.02	1.0	+0.60	950
JWC95SR	260	520	6000	2.0x10 <sup>-2</sup>	4600	0.02	1.0	+0.60	1800
JWC105SR	430	860	5500	3.2x10 <sup>-2</sup>	5800	0.02	1.0	+0.60	2400

※Note: Inertia moment and the weight are calculated as per the maximum aperture.If you need other dimensions, please feel free to contact us.

## Disc Flexible Coupling “DKD-CE” Series (Clamp Type) (Bores: 5-45 mm)



### Features:

- Stainless plate springs absorb angular misalignment and shaft end-play.
- High torque capacity and excellent response.
- Identical clockwise and anticlockwise rotational characteristic.
- For servo motor and step motor connect.
- Clamp type

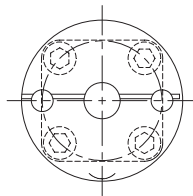
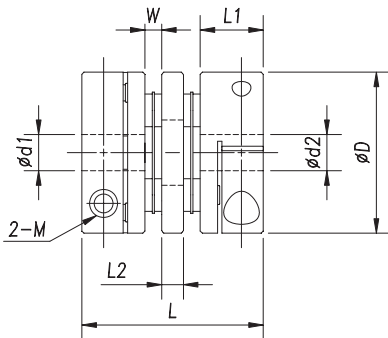

Material		Accessories
Body	Plate	
Aluminum Alloy	Stainless Steel	Clamp Screw

## Dimensions

Code	D	d1/d2	L	L1	L2	L3	Clamp Screw	
	mm	mm	mm	mm	mm	mm	Thread	Wrench Torque(N•m)
DKD26CE	26	5 ~ 10	35	2.5	11.5	7.0	M3	1.5
DKD34CE	34	8 ~ 14	45	3.1	14.1	10.6	M4	1.5
DKD39CE	39	10 ~ 16	49	4.1	15.0	10.8	M4	2.5
DKD44CE	44	11 ~ 19	50	4.5	15.0	11.0	M4	2.5
DKD56CE	56	14 ~ 24	63	5.0	20.0	13.0	M5	7.0
DKD68CE	68	19 ~ 35	74	6.0	24.0	14.0	M6	12
DKD82CE	82	24 ~ 40	98	8.0	30.0	22.0	M8	16
DKD94CE	94	25 ~ 40	98	8.0	30.0	22.0	M8	28
DKD104CE	104	30 ~ 45	102	10.0	30.0	22.0	M8	28

## Technical Properties

Code	Rated Torque	Max. Torque	Max. Speed	Moment of Inertia	Static Torsional Stiffness	Errors of Eccentricity	Errors of Angularity	Errors of Shaft End-Play	Mass
	N•m	N•m	rpm	Kg•m <sup>2</sup>	N•m/rad	mm	°	mm	g
DKD26CE	1.4	2.8	10000	3.3x10 <sup>-6</sup>	950	0.04	1.5	±0.4	34
DKD34CE	2.8	5.6	10000	8.9x10 <sup>-6</sup>	1960	0.04	1.5	±0.4	70
DKD39CE	5.8	11.6	10000	2.4x10 <sup>-5</sup>	4500	0.04	1.5	±0.4	118
DKD44CE	8.7	17.4	10000	3.2x10 <sup>-5</sup>	10500	0.04	1.5	±0.4	142
DKD56CE	25	50	10000	1.1x10 <sup>-4</sup>	18500	0.04	1.5	±0.4	296
DKD68CE	55	110	10000	2.8x10 <sup>-4</sup>	21800	0.04	1.5	±0.4	544
DKD82CE	80	160	10000	1.0x10 <sup>-3</sup>	10500	0.04	1.5	±0.4	1020
DKD94CE	185	370	10000	1.76x10 <sup>-3</sup>	84500	0.04	1.5	±0.4	1210
DKD104CE	255	510	10000	1.86x10 <sup>-3</sup>	125500	0.04	1.5	±0.4	1460

※Note: Inertia moment and the weight are calculated as per the maximum aperture.If you need other dimensions, please feel free to contact us.



## Disc Flexible Coupling “DKD-CR” Series (Clamp Type) (Bores: 6-30 mm)



**Features:**

- Stainless plate springs absorb angular misalignment and shaft end-play.
- High torque capacity and excellent response.
- Identical clockwise and anticlockwise rotational characteristic.
- For servo motor and step motor connect.
- Clamp type

Material		Accessories
Body	Plate	
Aluminum Alloy	Stainless Steel	Clamp Screw

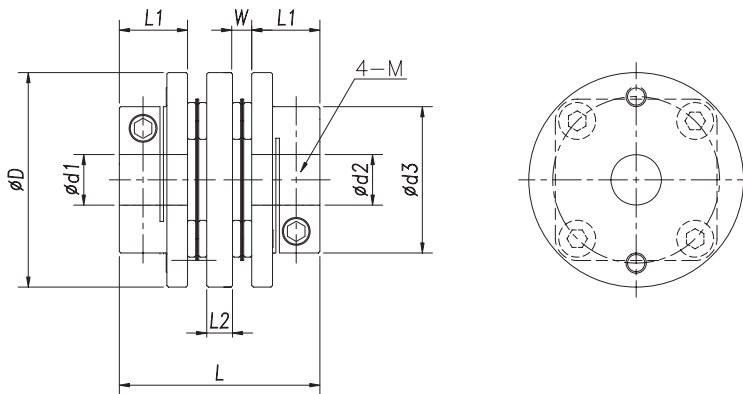

### Dimensions

Code	D	d1/d2	L	L1	L2	L3	Clamp	
	mm	mm	mm	mm	mm	mm	Thread	Wrench Torque(N•m)
DKD34CR	34	6 ~ 9	37	21.6	12	3	M3	1.5
DKD44CR	44	10 ~ 14	47	29.6	15	4	M4	3.4
DKD56CR	56	14 ~ 20	61	38.0	20	5	M5	7.0
DKD68CR	68	15 ~ 25	74	46.0	24	6	M6	14
DKD82CR	82	20 ~ 30	98	56.0	30	8	M8	25

### Technical Properties

Code	Rated Torque	Max. Torque	Max. Speed	Moment of Inertia	Static Torsional Stiffness	Errors of Eccentricity	Errors of Angularity	Errors of Shaft End-Play	Mass
	N•m	N•m	rpm	Kg•m <sup>2</sup>	N•m/rad	mm	°	mm	g
DKD34CR	2.8	5.6	6000	6.5x10 <sup>-6</sup>	1300	0.02	2.0	±0.3	46
DKD44CR	8.7	17.4	6000	25.4x10 <sup>-6</sup>	2800	0.02	2.0	±0.3	98
DKD56CR	25	50	6000	82.51x10 <sup>-6</sup>	4000	0.02	2.0	±0.3	194
DKD68CR	55	110	6000	225x10 <sup>-6</sup>	6300	0.02	2.0	±0.3	376
DKD82CR	80	160	6000	985x10 <sup>-6</sup>	8300	0.02	2.0	±0.3	640

※Note: Inertia moment and the weight are calculated as per the maximum aperture. If you need other dimensions, please feel free to contact us.

## Disc Flexible Coupling “DKS-CE” Series (Clamp Type) (Bores: 5-45 mm)



**Features:**

- Stainless plate springs absorb angular misalignment and shaft end-play.
- High torque capacity and excellent response.
- Identical clockwise and anticlockwise rotational characteristic.
- For servo motor and step motor connect.
- Clamp type

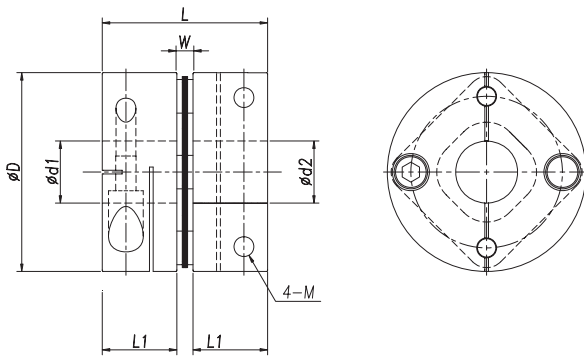

Material		Accessories
Body	Plate	
Aluminum Alloy	Stainless Steel	Clamp Screw

### Dimensions

型号	D	d1/d2	L	W	L1	Clamp Screw	
	mm	mm	mm	mm	mm	Thread	Wrench Torque (N•m)
DKS26CE	26	5 ~ 10	25.5	2.5	11.5	M3	1.5
DKS34CE	34	8 ~ 14	31.3	3.1	14.1	M4	1.5
DKS39CE	39	10 ~ 16	34.1	4.1	15.0	M4	2.5
DKS44CE	44	11 ~ 19	34.5	4.5	15.0	M4	2.5
DKS56CE	56	14 ~ 24	45.0	5.0	20.0	M5	7.0
DKS68CE	68	19 ~ 35	54.0	6.0	24.0	M6	12
DKS82CE	82	24 ~ 40	68.0	8.0	30.0	M8	16
DKS94CE	94	25 ~ 40	68.0	8.0	30.0	M8	28
DKS104CE	104	30 ~ 45	70.0	10.0	30.0	M8	28

### Technical Properties

Code	Rated Torque	Max. Torque	Max. Speed	Moment of Inertia	Static Torsional Stiffness	Errors of Angularity	Errors of Shaft End-Play	Mass
	N•m	N•m	rpm	Kg•m <sup>2</sup>	N•m/rad	°	mm	g
DKS26CE	1.4	2.8	10000	1.8x10 <sup>-6</sup>	690	1.0	±0.2	24
DKS34CE	2.8	5.6	10000	7.2x10 <sup>-6</sup>	1650	1.0	±0.2	46
DKS39CE	5.8	11.6	10000	1.8x10 <sup>-5</sup>	2500	1.0	±0.2	78
DKS44CE	8.7	17.4	10000	2.5x10 <sup>-5</sup>	2900	1.0	±0.2	96
DKS56CE	25	50	10000	1.0x10 <sup>-4</sup>	8400	1.0	±0.2	206
DKS68CE	55	110	10000	1.9x10 <sup>-4</sup>	11500	1.0	±0.2	366
DKS82CE	80	160	10000	7.0x10 <sup>-4</sup>	14500	1.0	±0.2	710
DKS94CE	185	370	10000	1.23x10 <sup>-3</sup>	16900	1.0	±0.2	960
DKS104CE	255	510	10000	1.86x10 <sup>-3</sup>	25100	1.0	±0.2	1190

※Note: Inertia moment and the weight are calculated as per the maximum aperture. If you need other dimensions, please feel free to contact us.

## Disc Flexible Coupling “DKS-CR” Series (Clamp Type) (Bores: 6-30 mm)



**Features:**

- Stainless plate springs absorb angular misalignment and shaft end-play.
- High torque capacity and excellent response.
- Identical clockwise and anticlockwise rotational characteristic.
- For servo motor and step motor connect.
- Clamp type

Material		Accessories
Body	Plate	
Aluminum Alloy	Stainless Steel	Clamp Screw

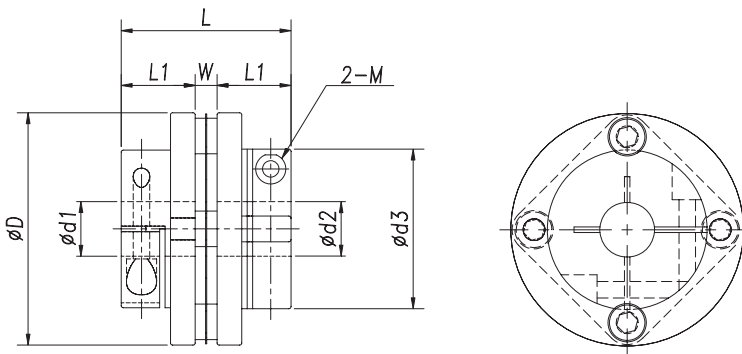

### Dimensions

Code	D	d1/d2	L	d3	L1	W	Clamp Screw	
	mm	mm	mm	mm	mm	mm	Thread	Wrench Torque(N•m)
DKS34CR	34	6 ~ 9	27	21.6	12	3	M3	1.5
DKS44CR	44	10 ~ 14	34	29.6	15	4	M4	3.4
DKS56CR	56	14 ~ 20	45	38.0	20	5	M5	7.0
DKS68CR	68	15 ~ 25	54	46.0	24	6	M6	14
DKS82CR	82	20 ~ 30	68	56.0	30	8	M8	25

### Technical Properties

Code	Rated Torque	Max. Torque	Max. Speed	Moment of Inertia	Static Torsional Stiffness	Errors of Eccentricity	Errors of Angularity	Errors of Shaft End-Play	Mass
	N•m	N•m	rpm	Kg•m <sup>2</sup>	N•m/rad	mm	°	mm	g
DKS34CR	2.8	5.6	6000	3.8x10 <sup>-6</sup>	1500	0.02	1.0	±0.15	38
DKS44CR	8.7	17.4	6000	14.5x10 <sup>-6</sup>	3000	0.02	1.0	±0.15	84
DKS56CR	25	50	6000	48.5x10 <sup>-6</sup>	4200	0.02	1.0	±0.15	132
DKS68CR	55	110	6000	126x10 <sup>-6</sup>	6500	0.02	1.0	±0.15	232
DKS82CR	80	160	6000	565x10 <sup>-6</sup>	8600	0.02	1.0	±0.15	420

※Note: Inertia moment and the weight are calculated as per the maximum aperture. If you need other dimensions, please feel free to contact us.

## Beam Flexible Coupling “BMCH-CE” Series (Clamp Type) (Bores: 4-19 mm)



**Features:**

- One-piece metal spring coupling
- Absorption of parallel, angular misalignments and shaft end play by spring action.
- Absorption of large angular misalignments by spring action.
- Zero Backlash
- Material: Aluminum Alloy or Stainless Steel.
- Clamp Type

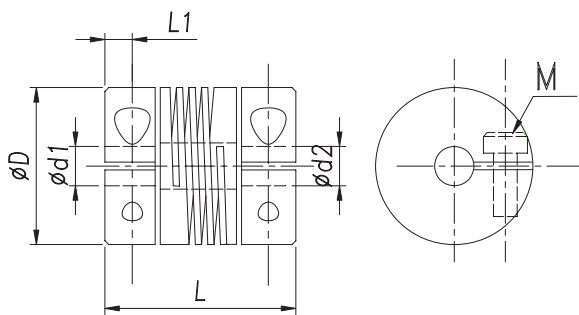

Material of the body	Accessories
Aluminum Alloy (BMCH-CE) or Stainless Steel (BMCH-CES)	Clamp Screw

### Dimensions

型号	D	d1/d2	L	L1	Clamp Screw	
	mm	mm	mm	mm	Thread	Wrench Torque(N•m)
BMCH16CE	16	4 ~ 6.35	22.9	3.10	M2.5	1.0
BMCH16CES						
BMCH20CE	20	5 ~ 10	31.8	4.15	M3	1.0
BMCH20CES						
BMCH25CE	25	6 ~ 13	38.1	5.00	M3	2.0
BMCH25CES						
BMCH32CE	32	8 ~ 15	41.3	5.90	M5	4.0
BMCH32CES						
BMCH42CE	42	12 ~ 19	51.0	6.70	M6	7.5
BMCH42CES						

### Technical Properties

Code	Rated Torque	Max. Torque	Max. Speed	Moment of Inertia	Static Torsional Stiffness	Errors of Eccentricity	Errors of Angularity	Errors of Shaft End-Play	Mass
	N•m	N•m	rpm	Kg•m <sup>2</sup>	N•m/rad	mm	°	mm	g
BMCH16CE	0.5	1.0	8000	9.0x10 <sup>-7</sup>	46	0.10	2.0	±0.15	14
BMCH16CES	1.0	2.0		2.4x10 <sup>-6</sup>	83	0.10	2.0	±0.15	40
BMCH20CE	1.4	2.8	6000	2.5x10 <sup>-7</sup>	118	0.10	2.0	±0.15	32
BMCH20CES	2.2	4.4		7.3x10 <sup>-6</sup>	246	0.10	2.0	±0.15	96
BMCH25CE	1.6	3.2	5000	8.9x10 <sup>-6</sup>	167	0.10	2.0	±0.15	46
BMCH25CES	3.1	6.2		2.6x10 <sup>-6</sup>	315	0.10	2.0	±0.15	134
BMCH32CE	4.2	8.4	4500	3.2x10 <sup>-5</sup>	225	0.10	2.0	±0.15	92
BMCH32CES	7.5	15.0		8.6x10 <sup>-5</sup>	845	0.10	2.0	±0.15	268
BMCH42CE	9.0	18.0	4500	9.8x10 <sup>-5</sup>	346	0.10	2.0	±0.15	136
BMCH42CES	14.0	28.0		3.0x10 <sup>-4</sup>	990	0.10	2.0	±0.15	392

※Note: Inertia moment and the weight are calculated as per the maximum aperture.If you need other dimensions, please feel free to contact us.

### Beam Flexible Coupling “BMCH-SE” Series (Set Screw) (Bores: 3-19 mm)



#### Features:

- One-piece metal spring coupling.
- Absorption of parallel, angular misalignments and shaft end play by spring action.
- Absorption of large angular misalignments by spring action.
- Zero Backlash
- Material: Aluminum Alloy or Stainless Steel.
- Set Screw.

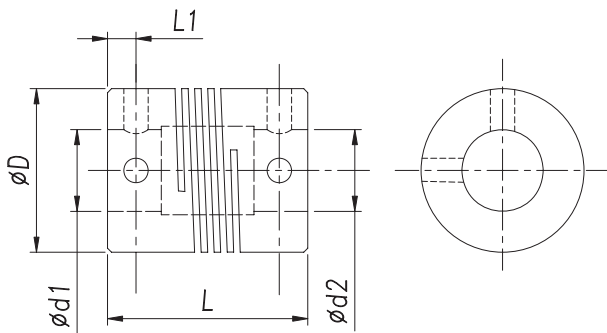

Material of the body	Accessories
Aluminum Alloy (BMCH-SE) or Stainless Steel (BMCH-SES)	Set Screw

### Dimensions

Code	D	d1/d2	L	L1	Set Screw	
	mm	mm	mm	mm	Thread	Wrench Torque(N•m)
BMCH16SE	16	3 ~ 6.35	19.0	2.55	M3	0.7
BMCH16SES						
BMCH20SE	20	5 ~ 10	26.4	3.55	M4	1.7
BMCH20SES						
BMCH25SE	25	6 ~ 13	28.6	3.60	M5	1.7
BMCH25SES						
BMCH32SE	32	8 ~ 15	38.1	4.15	M5	3.8
BMCH32SES						
BMCH42SE	42	12 ~ 19	48.0	5.25	M6	4.0
BMCH42SES						

### Technical Properties

Code	Rated Torque	Max. Torque	Max. Speed	Moment of Inertia	Static Torsional Stiffness	Errors of Eccentricity	Errors of Angularity	Errors of Shaft End-Play	Mass
	N•m	N•m	rpm	Kg•m <sup>2</sup>	N•m/rad	mm	°	mm	g
BMCH16SE	0.5	1.0	10000	6.9x10 <sup>-7</sup>	110	0.10	1.5	±0.15	12
BMCH16SES	1.0	2.0		2.2x10 <sup>-6</sup>	230	0.10	2.0	±0.15	36
BMCH20SE	1.4	2.8	10000	2.8x10 <sup>-7</sup>	170	0.10	1.5	±0.15	28
BMCH20SES	2.2	4.4		7.0x10 <sup>-6</sup>	320	0.10	2.0	±0.15	76
BMCH25SE	1.6	3.2	8000	5.1x10 <sup>-6</sup>	260	0.10	2.0	±0.15	44
BMCH25SES	3.1	6.2		2.3x10 <sup>-6</sup>	790	0.10	2.0	±0.15	120
BMCH32SE	4.2	8.4	8000	2.1x10 <sup>-5</sup>	560	0.10	2.0	±0.15	78
BMCH32SES	7.5	15.0		8.3x10 <sup>-5</sup>	980	0.10	2.0	±0.15	214
BMCH42SE	9.0	18.0	6000	9.0x10 <sup>-5</sup>	560	0.15	1.5	±0.15	130
BMCH42SES	14.0	28.0		2.7x10 <sup>-4</sup>	1450	0.10	2.0	±0.15	362

※Note: Inertia moment and the weight are calculated as per the maximum aperture.If you need other dimensions, please feel free to contact us.

### Beam Flexible Coupling “BMCP-CR” Series (Set Screw) (Bores: 3-24 mm)



#### Features:

- One-piece metal spring coupling.
- Absorption of parallel, angular misalignments and shaft end play by spring action. Zero Backlash
- Absorption of large angular misalignments by spring action.
- Material: Aluminum Alloy or Stainless Steel.
- Clamp Type.

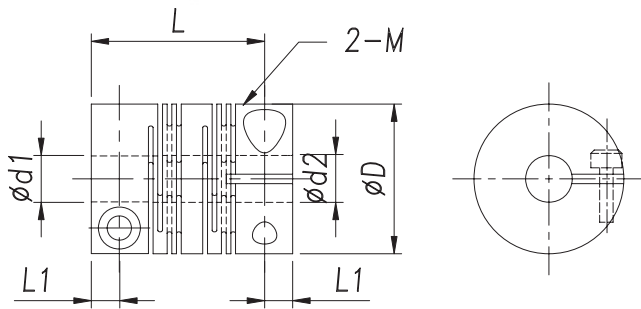

Material of the body	Accessories
Aluminum Alloy ( BMCP-CR) or Stainless Steel ( BMCP-CRS)	Clamp Screw

### Dimensions

Code	D	d1/d2	L	L1	Clamp Screw	
	mm	mm	mm	mm	Thread	Wrench Torque (N•m)
BMCP12CR	12	3 ~ 5	18.5	2.50	M2	0.5
BMCP12CRS						
BMCP16CR	16	4 ~ 6.35	23	3.30	M2.5	1.0
BMCP16CRS						
BMCP20CR	20	5 ~ 9.525	26	3.75	M2.5	1.0
BMCP20CRS						
BMCP25CR	25	8 ~ 12	31	4.25	M3	1.5
BMCP25CRS						
BMCP32CR	32	10 ~ 14	41	6.00	M4	2.5
BMCP32CRS						
BMCP40CR	40	10 ~ 18	56	8.50	M5	4.0
BMCP40CRS						
BMCP50CR	50	12 ~ 19	71	10.50	M6	8.0
BMCP50CRS						
BMCP63CR	63	14 ~ 24	90	13.00	M8	16
BMCP63CRS						

### Technical Properties

Code	Rated Torque	Max. Torque	Max. Speed	Moment of Inertia	Static Torsional Stiffness	Errors of Eccentricity	Errors of Angularity	Errors of Shaft End-Play	Mass
	N•m	N•m	rpm	Kg•m <sup>2</sup>	N•m/rad	mm	°	mm	g
BMCP12CR	0.5	1.0	10000	7.6x10 <sup>-8</sup>	34	0.10	1.5	±0.30	4
BMCP12CRS	0.8	1.6		2.1x10 <sup>-7</sup>	62	0.10	1.5	±0.30	8
BMCP16CR	0.5	1.6	10000	3.2x10 <sup>-7</sup>	46	0.10	1.5	±0.30	18
BMCP16CRS	1.1	2.2		8.9x10 <sup>-7</sup>	83	0.10	1.5	±0.30	32
BMCP20CR	1.1	2.2	9300	8.8x10 <sup>-7</sup>	118	0.10	1.5	±0.30	66
BMCP20CRS	1.6	3.2		2.4x10 <sup>-8</sup>	246	0.10	1.5	±0.30	138
BMCP25CR	1.4	2.8	7500	2.5x10 <sup>-6</sup>	167	0.15	1.5	±0.35	272
BMCP25CRS	2.2	4.4		7.0x10 <sup>-6</sup>	315	0.15	1.5	±0.35	530
BMCP32CR	2.8	5.6	6000	9.6x10 <sup>-6</sup>	225	0.15	1.5	±0.35	14
BMCP32CRS	5.5	11.0	4600	2.6x10 <sup>-5</sup>	845	0.15	1.5	±0.35	26
BMCP40CR	6.3	12.6	3600	3.2x10 <sup>-5</sup>	346	0.20	1.5	±0.35	48
BMCP40CRS	8.7	17.4		8.9x10 <sup>-5</sup>	990	0.20	1.5	±0.35	78
BMCP50CR	11	22	3000	9x10 <sup>-5</sup>	580	0.20	1.5	±0.35	174
BMCP50CRS	16	32		2.7x10 <sup>-4</sup>	1380	0.20	1.5	±0.35	372
BMCP63CR	22	44	2200	3.1x10 <sup>-4</sup>	843	0.20	1.5	±0.35	760
BMCP63CRS	38	76		8.7x10 <sup>-4</sup>	1790	0.20	1.5	±0.35	1410

\*Note: Inertia moment and the weight are calculated as per the maximum aperture. If you need other dimensions, please feel free to contact us.

### Beam Flexible Coupling “BMCP-SR” Series (Set Screw) (Bores: 3-24 mm)



#### Features:

- One-piece metal spring coupling.
- Absorption of parallel, angular misalignments and shaft end play by spring action.
- Absorption of large angular misalignments by spring action.
- Zero Backlash
- Material: Aluminum Alloy or Stainless Steel.
- Set Screw.

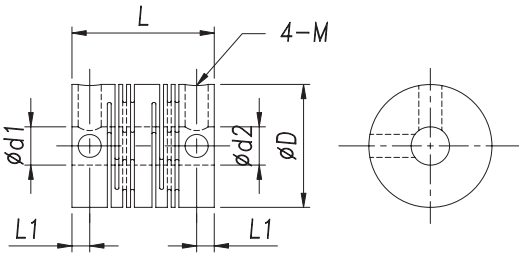

Material of the body	Accessories
Aluminum Alloy (BMCH-SR) or Stainless Steel (BMCH-SRS)	Set Screw

### Dimensions

Code	D	d1/d2	L	L1	Set Screw	
	mm	mm	mm	mm	Thread	Wrench Torpque (N•m)
BMCP12SR	12	3 ~ 5	18.5	18.5	M2.5	0.5
BMCP12SRS						
BMCP16SR	16	4 ~ 6.35	23	23	M3	0.7
BMCP16SRS						
BMCP20SR	20	5 ~ 9.525	26	26	M3	0.7
BMCP20SRS						
BMCP25SR	25	8 ~ 12	31	4.0	M4	1.7
BMCP25SRS						
BMCP32SR	32	10 ~ 14	41	6.0	M4	1.7
BMCP32SRS						
BMCP40SR	40	10 ~ 18	56	8.5	M5	4.0
BMCP40SRS						
BMCP50SR	50	12 ~ 19	71	10.5	M6	7.0
BMCP50SRS						
BMCP63SR	63	14 ~ 24	90	13.0	M8	15
BMCP63SRS						

### Technical Properties

Code	Rated Torque	Max. Torque	Max. Speed	Moment of Inertia	Static Torsional Stiffness	Errors of Eccentricity	Errors of Angularity	Errors of Shaft End-Play	Mass
	N•m	N•m	rpm	Kg•m <sup>2</sup>	N•m/rad	mm	°	mm	g
BMCP12SR	0.5	1.0	30000	8.2x10 <sup>-8</sup>	33	0.10	1.5	±0.30	4
BMCP12SRS	0.8	1.6		2.0x10 <sup>-7</sup>	60	0.10	1.5	±0.30	12
BMCP16SR	0.5	1.6	22000	3.2x10 <sup>-7</sup>	46	0.10	1.5	±0.30	8
BMCP16SRS	1.1	2.2		8.3x10 <sup>-7</sup>	80	0.10	1.5	±0.30	22
BMCP20SR	1.1	2.2	18000	8.8x10 <sup>-7</sup>	115	0.10	1.5	±0.30	16
BMCP20SRS	1.6	3.2		2.2x10 <sup>-8</sup>	235	0.10	1.5	±0.30	40
BMCP25SR	1.4	2.8	14000	2.5x10 <sup>-6</sup>	165	0.15	1.5	±0.35	28
BMCP25SRS	2.2	4.4		6.7x10 <sup>-6</sup>	315	0.15	1.5	±0.35	74
BMCP32SR	2.8	5.6	10000	9.5x10 <sup>-6</sup>	270	0.15	1.5	±0.35	62
BMCP32SRS	5.5	11.0		2.5x10 <sup>-5</sup>	837	0.15	1.5	±0.35	162
BMCP40SR	6.3	12.6	9400	3.1x10 <sup>-5</sup>	345	0.20	1.5	±0.35	134
BMCP40SRS	8.7	17.4		8.6x10 <sup>-5</sup>	980	0.20	1.5	±0.35	354
BMCP50SR	11	22	7600	1.0x10 <sup>-5</sup>	580	0.20	1.5	±0.35	266
BMCP50SRS	16	32		2.6x10 <sup>-4</sup>	1385	0.20	1.5	±0.35	710
BMCP63SR	22	44	6000	3.0x10 <sup>-4</sup>	830	0.20	1.5	±0.35	500
BMCP63SRS	38	76		8.2x10 <sup>-4</sup>	1795	0.20	1.5	±0.35	1310

※Note: Inertia moment and the weight are calculated as per the maximum aperture.If you need other dimensions, please feel free to contact us.

## Disc Coupling “DKD-KS” Series (Keyway Connecting) (Bores: 8-60 mm)



**Features:**

- Using keyway connect, plate spring coupling
- Zero Backlash
- Excellent response and high torque capacity
- Identical clockwise and anticlockwise rotational characteristics
- Stainless steel plate springs absorb parallel, angular misalignments and shaft end-play
- For servo motor and step motor.

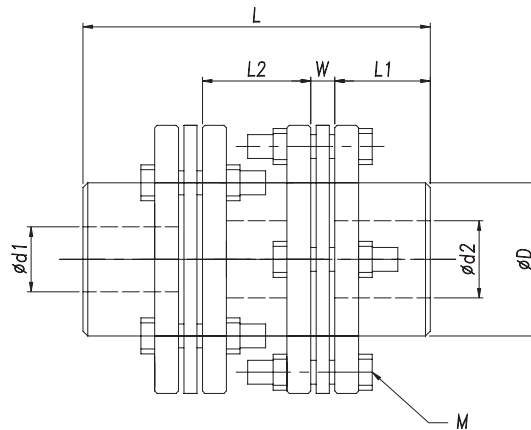

### Dimensions

Code	D	d1/d2	D1	L	L1	W	M	Rated Torque
	mm	mm	mm	mm	mm	mm		N•m
DKD56KS	56	8 ~ 20	32	74	20	5	M5	25
DKD68KS	68	11 ~ 25	40	86	25	6	M6	55
DKD82KS	82	14 ~ 35	54	98	30	6	M6	80
DKD94KS	94	14 ~ 38	58	106	30	8	M8	170
DKD104KS	104	19 ~ 42	68	120	35	10	M8	240
DKD126KS	126	22 ~ 50	78	140	40	11	M10	420
DKD144KS	144	30 ~ 60	88	160	45	12	M12	700

### Technical Properties

Code	Max. Torque	Max. Speed	Moment of Inertia	Static Torsional Stiffness	Errors of Eccentricity	Errors of Angularity	Errors of Shaft End-Play	Mass
	N•m	rpm	Kg•m <sup>2</sup>	N•m/rad	mm	°	mm	g
DKD56KS	50	15000	0.19x10 <sup>-3</sup>	7.5x10 <sup>3</sup>	0.04	1.5	±1.0	500
DKD68KS	110	14000	0.54x10 <sup>-3</sup>	13x10 <sup>3</sup>	0.04	1.5	±1.5	900
DKD82KS	160	11000	1.6x10 <sup>-3</sup>	39x10 <sup>3</sup>	0.04	1.5	±2.0	1700
DKD94KS	340	9500	2.8x10 <sup>-3</sup>	78x10 <sup>3</sup>	0.04	1.5	±2.0	2400
DKD104KS	480	9800	4.6x10 <sup>-3</sup>	115x10 <sup>3</sup>	0.04	1.5	±2.0	3300
DKD126KS	840	8800	11.9x10 <sup>-3</sup>	200x10 <sup>3</sup>	0.04	1.5	±2.0	5800
DKD144KS	1400	6000	18.2x10 <sup>-3</sup>	350x10 <sup>3</sup>	0.04	1.5	±2.0	8600

※Note: Inertia moment and the weight are calculated as per the maximum aperture. If you need other dimensions, please feel free to contact us.



## Disc Coupling “DKS-KS” Series (Keyway Connecting) (Bores: 8-60 mm)



### Features:

- Using keyway connect, plate spring coupling
- Zero Backlash
- Excellent response and high torque capacity
- Identical clockwise and anticlockwise rotational characteristics
- Stainless steel plate springs absorb parallel, angular misalignments and shaft end-play
- For servo motor and step motor.

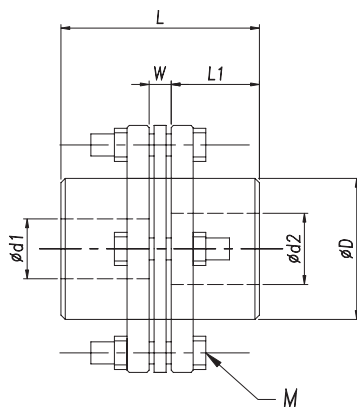

## Dimensions

Code	D	d1/d2	D1	L	L1	W	M	Rated Torque
	mm	mm	mm	mm	mm	mm		N•m
DKS56KS	56	8 ~ 20	32	45	20	5	M5	25
DKS68KS	68	11 ~ 25	40	56	25	6	M6	55
DKS82KS	82	14 ~ 35	54	66	30	6	M6	80
DKS94KS	94	14 ~ 38	58	68	30	8	M8	170
DKS104KS	104	19 ~ 42	68	80	35	10	M8	240
DKS126KS	126	22 ~ 50	78	91	40	11	M10	420
DKS144KS	144	30 ~ 60	88	102	45	12	M12	700

## Technical Properties

Code	Max. Torque	Max. Speed	Moment of Inertia	Static Torsional Stiffness	Errors of Eccentricity	Errors of Angularity	Errors of Shaft End-Play	Mass
	N•m	rpm	Kg•m <sup>2</sup>	N•m/rad	mm	°	mm	g
DKS56KS	50	20000	0.10x10 <sup>-3</sup>	15x10 <sup>3</sup>	0.02	1.0	±0.5	300
DKS68KS	110	15000	0.28x10 <sup>-3</sup>	28x10 <sup>3</sup>	0.02	1.0	±0.8	500
DKS82KS	160	14000	0.85x10 <sup>-3</sup>	81x10 <sup>3</sup>	0.02	1.0	±1.0	1000
DKS94KS	340	11000	1.5x10 <sup>-3</sup>	165x10 <sup>3</sup>	0.02	1.0	±1.0	1400
DKS104KS	480	9800	2.4x10 <sup>-3</sup>	240x10 <sup>3</sup>	0.02	1.0	±1.0	2100
DKS126KS	840	8000	6.3x10 <sup>-3</sup>	410x10 <sup>3</sup>	0.02	1.0	±1.0	3400
DKS144KS	1400	6800	9.3x10 <sup>-3</sup>	760x10 <sup>3</sup>	0.02	1.0	±1.0	4900

※Note: Inertia moment and the weight are calculated as per the maximum aperture. If you need other dimensions, please feel free to contact us.

## Disc Coupling “DKD-ZE” Series (Locking Assemblies) (Bores: 18-75 mm)



**Features:**

- Using locking assemblies connect, plate spring coupling
- Zero Backlash
- Excellent response and high torque capacity
- Identical clockwise and anticlockwise rotational characteristics
- Stainless steel plate springs absorb parallel, angular misalignments and shaft end-play
- For servo motor and step motor.

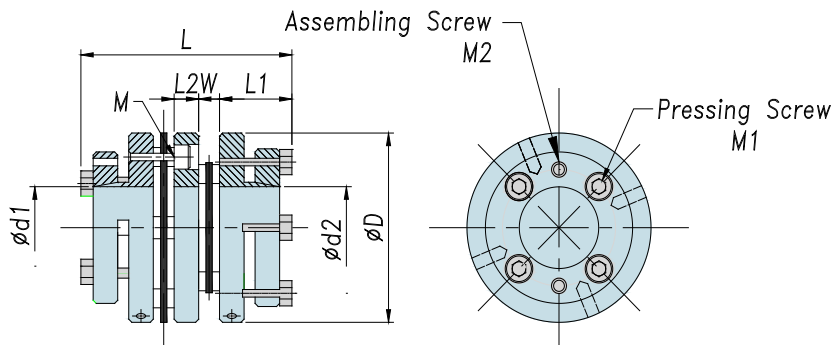

### Dimensions

Code	D	d1/d2	L	L1	W	M	M1	M2	Rated Torque
	mm	mm	mm	mm	mm				N·m
DKD70ZE	70	18 ~ 35	80	29	7.0	M6	4-M6	2-M6	70
DKD80ZE	80	22 ~ 35	88	31	8.0	M8	4-M6	2-M6	125
DKD90ZE	90	28 ~ 48	88	31	8.0	M8	6-M6	3-M6	180
DKD100ZE	100	32 ~ 60	88	31	8.0	M8	6-M6	3-M6	280
DKD126ZE	126	38 ~ 65	107	35.5	11.0	M10	6-M6	3-M6	450
DKD144ZE	144	45 ~ 75	122	42	12.0	M12	6-M8	3-M8	760

### Technical Properties

Code	Max. Torque	Max. Speed	Moment of Inertia	Static Torsional Stiffness	Errors of Eccentricity	Errors of Angularity	Errors of Shaft End-Play	Mass
	N·m	rpm	Kg·m <sup>2</sup>	N·m/rad	mm	°	mm	g
DKD70ZE	140	13000	0.81x10 <sup>-3</sup>	30x10 <sup>3</sup>	0.2	1.0	±1.0	1150
DKD80ZE	250	11000	1.32x10 <sup>-3</sup>	32x10 <sup>3</sup>	0.3	1.0	±1.0	1580
DKD90ZE	360	10000	2.56x10 <sup>-3</sup>	68x10 <sup>3</sup>	0.3	1.0	±1.0	1980
DKD100ZE	560	8000	3.68x10 <sup>-3</sup>	79x10 <sup>3</sup>	0.3	1.0	±1.0	2260
DKD126ZE	900	10000	7.95x10 <sup>-3</sup>	216x10 <sup>3</sup>	0.02	1.0	±1.0	4300
DKD144ZE	1520	8000	16.70x10 <sup>-3</sup>	380x10 <sup>3</sup>	0.02	1.0	±1.0	6200

※Note: Inertia moment and the weight are calculated as per the maximum aperture. If you need other dimensions, please feel free to contact us.

## Disc Coupling “DKS-ZE” Series (Locking Assemblies) (Bores: 18-75 mm)



Features:

- Using locking assemblies connect, plate spring coupling
- Zero Backlash
- Excellent response and high torque capacity
- Identical clockwise and anticlockwise rotational characteristics
- Stainless steel plate springs absorb parallel, angular misalignments and shaft end-play
- For servo motor and step motor.

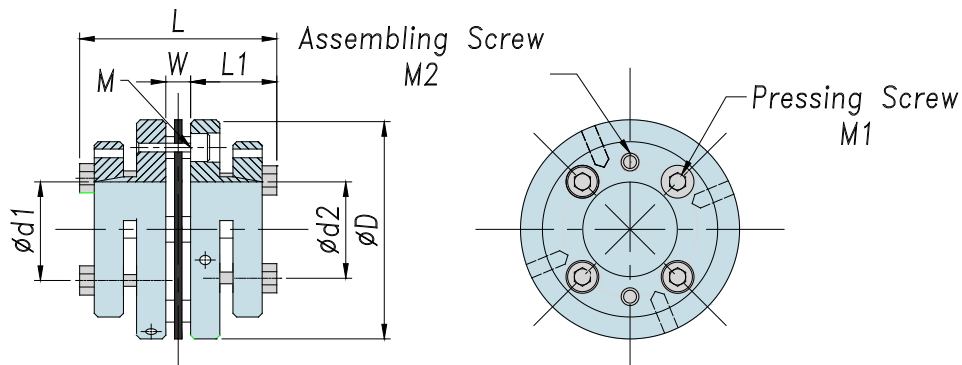

### Dimensions

Code	D	d1/d2	L	L1	W	M	M1	M2	Rated Torque
	mm	mm	mm	mm	mm				N•m
DKS70ZE	70	18 ~ 35	65	29	7.0	M6	4-M6	2-M6	70
DKS80ZE	80	18 ~ 35	70	31	8.0	M8	4-M6	2-M6	125
DKS90ZE	90	28 ~ 48	70	31	8.0	M8	6-M6	3-M6	180
DKS100ZE	100	32 ~ 60	70	31	8.0	M8	6-M6	3-M6	280
DKS126ZE	126	38 ~ 65	82	35.5	11.0	M10	6-M6	3-M6	450
DKS144ZE	144	45 ~ 75	96	42	12.0	M12	6-M8	3-M8	760

### Technical Properties

Code	Max. Torque	Max. Speed	Moment of Inertia	Static Torsional Stiffness	Errors of Eccentricity	Errors of Angularity	Errors of Shaft End-Play	Mass
	N•m	rpm	Kg•m <sup>2</sup>	N•m/rad	mm	°	mm	g
DKS70ZE	140	17000	0.65x10 <sup>-3</sup>	58x10 <sup>3</sup>	0.02	0.5	±0.5	950
DKS80ZE	250	16000	1.00x10 <sup>-3</sup>	62x10 <sup>3</sup>	0.02	0.5	±0.5	1240
DKS90ZE	360	14000	2.00x10 <sup>-3</sup>	140x10 <sup>3</sup>	0.02	0.5	±0.5	1650
DKS100ZE	560	12000	2.95x10 <sup>-3</sup>	160x10 <sup>3</sup>	0.02	0.5	±0.5	1800
DKS126ZE	900	10000	6.35x10 <sup>-3</sup>	450x10 <sup>3</sup>	0.02	0.5	±0.5	3300
DKS144ZE	1520	8000	11.33x10 <sup>-3</sup>	785x10 <sup>3</sup>	0.02	0.5	±0.5	4500

※Note: Inertia moment and the weight are calculated as per the maximum aperture. If you need other dimensions, please feel free to contact us.

## Oldham Coupling “OHC-C” Series (Clamp Type) (Bores: 4-25 mm)



Features:

- Oldham type flexible coupling.
- Allows high parallel and angular misalignments.
- High torsional stiffness and response.
- Simple configuration enable easy assembly.
- Zero Backlash.
- Clamp screw.

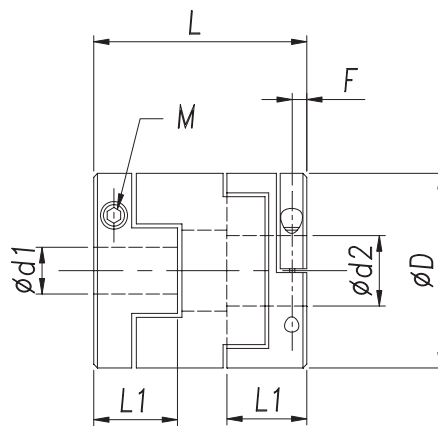

### Dimensions

Code	D	d1/d2	L	F	L1	M	Wrench Torque
	mm	mm	mm	mm	mm		N•m
OHC16	16	4 ~ 6	18	3.t5	7	M3	0.7
OHC20	20	6 ~ 8	23	4.5	9	M4	1.7
OHC25	25	6.35 ~ 10	28	5.5	11	M5	4.0
OHC32	32	8 ~ 14	33	6.5	13	M6	7.0
OHC40	40	8 ~ 14	35	7.0	14	M6	7.0
OHC50	50	12 ~ 16	38	8.5	17	M8	15.0
OHC63	63	16 ~ 25	47	10.5	21	M10	30.0

### Technical Properties

Code	Rated Torque	Max Torque	Max Speed	Moment of Inertia	Static Torsional Stiffness	Errors of Eccentricity	Errors of Angularity	Mass
	N•m	N•m	rpm	Kg•m <sup>2</sup>	N•m/rad	mm	°	g
OHC16	0.7	1.4	9000	3.0×10 <sup>-7</sup>	29	1.0	3.0	6
OHC20	1.6	3.2	7400	9.0×10 <sup>-7</sup>	58	1.4	3.0	14
OHC25	3.0	6.0	5800	2.8×10 <sup>-6</sup>	125	1.9	3.0	24
OHC32	5.5	11.0	4700	8.9×10 <sup>-5</sup>	260	2.4	3.0	46
OHC40	9.0	18.0	3600	2.1×10 <sup>-5</sup>	505	2.8	3.0	80
OHC50	19.0	38.0	3000	6.0×10 <sup>-5</sup>	780	3.3	3.0	144
OHC63	33.0	66.0	2400	2.1×10 <sup>-4</sup>	1200	3.8	3.0	318

※Note: Inertia moment and the weight are calculated as per the maximum aperture.If you need other dimensions, please feel free to contact us.

## Oldham Coupling “OHC-S” Series (Clamp type) (Bores: 4-25 mm)



Features:

- Oldham type flexible coupling.
- Allows high parallel and angular misalignments.
- High torsional stiffness and response.
- Simple configuration enable easy assembly.
- Zero Backlash.
- Set screw.

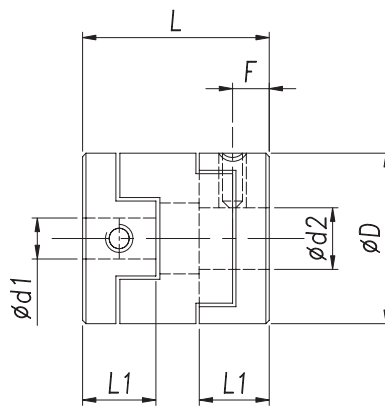

### Dimensions

Code	D	d1/d2	L	F	L1	M	Wrench Torque
	mm	mm	mm	mm	mm		N•m
OHC16S	16	4 ~ 6	18	3.5	7	M3	0.7
OHC20S	20	6 ~ 8	23	4.5	9	M4	1.7
OHC25S	25	6.35 ~ 10	28	5.5	11	M5	4.0
OHC32S	32	8 ~ 14	33	6.5	13	M6	7.0
OHC40S	40	8 ~ 14	35	7.0	14	M6	7.0
OHC50S	50	12 ~ 16	38	8.5	17	M8	15.0
OHC63S	63	16 ~ 25	47	10.5	21	M10	30.0

### Technical Properties

Code	Rated Torque	Max Torque	Max Speed	Moment of Inertia	Static Torsional Stiffness	Errors of Eccentricity	Errors of Angularity	Mass
	N•m	N•m	rpm	Kg•m <sup>2</sup>	N•m/rad	mm	°	g
OHC16S	0.7	1.4	9000	$3.0 \times 10^{-7}$	29	1.0	3.0	6
OHC20S	1.6	3.2	7400	$9.0 \times 10^{-7}$	58	1.4	3.0	14
OHC25S	3.0	6.0	5800	$2.8 \times 10^{-6}$	125	1.9	3.0	24
OHC32S	5.5	11.0	4700	$8.9 \times 10^{-5}$	260	2.4	3.0	46
OHC40S	9.0	18.0	3600	$2.1 \times 10^{-5}$	505	2.8	3.0	80
OHC50S	19.0	38.0	3000	$6.0 \times 10^{-5}$	780	3.3	3.0	144
OHC63S	33.0	66.0	2400	$2.1 \times 10^{-4}$	1200	3.8	3.0	318

※Note: Inertia moment and the weight are calculated as per the maximum aperture. If you need other dimensions, please feel free to contact us.

## Bellows Coupling “BLC-C” Series (Clamp Type) (Bores: 4-42 mm)



**Features:**

- High torque capacity and excellent response.
- Spring action bellows configuration absorbs parallel, angular misalignments and shaft end-play.
- High torsional stiffness and response.
- Identical clockwise and anticlockwise rotational characteristics.
- Zero Backlash.
- Clamp type

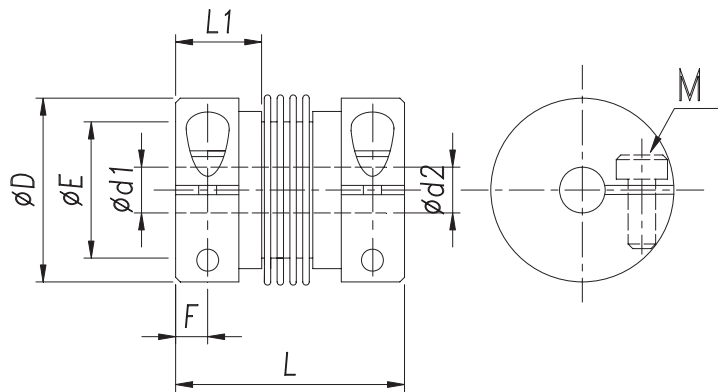

### Dimensions

Code	D	d1/d2	L	L1	F	E	M	Wrench Torque
	mm	mm	mm	mm	mm	mm		N•m
BLC16C	16	4 ~ 8	30	10.5	4.0	9.5	M3	0.7
BLC20C	20	6 ~ 12	33	10.5	4.0	12.5	M3	0.7
BLC25C	25	6 ~ 12	38	12.5	5.0	15.0	M4	1.7
BLC32C	32	8 ~ 14	43	14.0	6.0	21.0	M4	1.7
BLC40C	40	10 ~ 16	62	21.5	6.5	27.0	M5	4.0
BLC55C	55	12 ~ 19	72	23.0	7.0	40.0	M6	8.0
BLC65C	65	18 ~ 38	81	25.5	9.0	45.0	M8	15.0
BLC82C	82	20 ~ 42	103	34.5	11.0	56.0	M10	28.0

### Technical Properties

Code	Rated Torque	Max. Torque	Max. Speed	Moment of Inertia	Static Torsional Stiffness	Errors of Eccentricity	Errors of Angularity	Errors of Shaft End-Play	Mass
	N•m	N•m	rpm	Kg•m <sup>2</sup>	N•m/rad	mm	°	mm	g
BLC16C	0.8	1.6	18000	3.4x10 <sup>-7</sup>	100	0.10	1.5°	+0.3 -1.0	8
BLC20C	1.5	3.0	13000	8.9x10 <sup>-7</sup>	160	0.10	1.5°	+0.3 -1.0	14
BLC25C	2.0	4.0	11000	2.8x10 <sup>-6</sup>	220	0.15	2.0°	+0.5 -1.3	32
BLC32C	2.5	5.0	10000	8.8x10 <sup>-6</sup>	310	0.20	2.0°	+0.5 -1.3	52
BLC40C	10.0	20.0	8000	1.5x10 <sup>-5</sup>	520	0.20	2.0°	+0.7 -1.5	98
BLC55C	25.0	50.0	6000	2.3x10 <sup>-5</sup>	850	0.20	2.0°	+0.7 -1.5	200
BLC65C	60.0	120.0	4500	2.8x10 <sup>-5</sup>	960	0.20	2.0°	+0.7 -1.5	350
BLC82C	80.0	130.0	4000	6.0x10 <sup>-5</sup>	1290	0.20	2.0°	+0.7 -1.5	750

※Note: Inertia moment and the weight are calculated as per the maximum aperture. If you need other dimensions, please feel free to contact us.

## Bellows Coupling “BLC-S” Series (Clamp Type) (Bores: 4-42 mm)



**Features:**

- High torque capacity and excellent response.
- Spring action bellows configuration absorbs parallel, angular misalignments and shaft end-play.
- High torsional stiffness and response.
- Identical clockwise and anticlockwise rotational characteristics.
- Zero Backlash.
- Clamp type

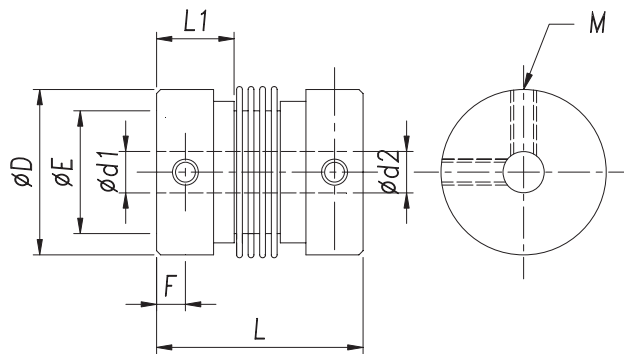

### Dimensions

Code	D	d1/d2	L	L1	F	E	M	Wrench Torque
	mm	mm	mm	mm	mm	mm		N•m
BLC16S	16	4 ~ 8	30	10.5	4.0	9.5	M3	0.7
BLC20S	20	6 ~ 12	33	10.5	4.0	12.5	M3	0.7
BLC25S	25	6 ~ 12	38	12.5	5.0	15.0	M4	1.7
BLC32S	32	8 ~ 14	43	14.0	6.0	21.0	M4	1.7
BLC40S	40	10 ~ 16	62	21.5	6.5	27.0	M5	4.0
BLC55S	55	12 ~ 19	72	23.0	7.0	40.0	M6	8.0
BLC65S	65	18 ~ 38	81	25.5	9.0	45.0	M8	15.0
BLC82S	82	20 ~ 42	103	34.5	11.0	56.0	M10	28.0

### Technical Properties

Code	Rated Torque	Max. Torque	Max. Speed	Moment of Inertia	Static Torsional Stiffness	Errors of Eccentricity	Errors of Angularity	Errors of Shaft End-Play	Mass
	N•m	N•m	rpm	Kg•m <sup>2</sup>	N•m/rad	mm	°	mm	g
BLC16S	0.8	1.6	18000	3.4x10 <sup>-7</sup>	100	0.10	1.5°	+0.3 -1.0	8
BLC20S	1.5	3.0	13000	8.9x10 <sup>-7</sup>	160	0.10	1.5°	+0.3 -1.0	14
BLC25S	2.0	4.0	11000	2.8x10 <sup>-6</sup>	220	0.15	2.0°	+0.5 -1.3	32
BLC32S	2.5	5.0	10000	8.8x10 <sup>-6</sup>	310	0.20	2.0°	+0.5 -1.3	52
BLC40S	10.0	20.0	8000	1.5x10 <sup>-5</sup>	520	0.20	2.0°	+0.7 -1.5	98
BLC55S	25.0	50.0	6000	2.3x10 <sup>-5</sup>	850	0.20	2.0°	+0.7 -1.5	200
BLC65S	60.0	120.0	4500	2.8x10 <sup>-5</sup>	960	0.20	2.0°	+0.7 -1.5	350
BLC82S	80.0	130.0	4000	6.0x10 <sup>-5</sup>	1290	0.20	2.0°	+0.7 -1.5	750

※Note: Inertia moment and the weight are calculated as per the maximum aperture. If you need other dimensions, please feel free to contact us.

## RGL-CE Rigid Coupling (OD from 16 to 32mm)



**Feature:**

- Elongated rigid coupling
- Can be used as connecting sleeve
- Aluminum alloy and stainless steel both available

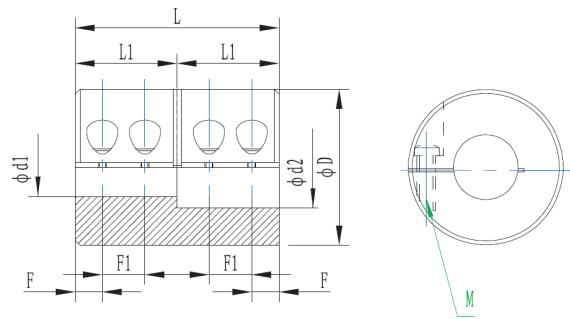

### Dimensions

Code	D	d1/d2	L	L1	F	F1	Clamp Screw nut	
	mm	mm	mm	mm	mm	mm	Thread	Wrench Torque(N•m)
RGL16CE	16	5 ~ 6	22	11	2.5	5.5	M2	0.5
RGL16CE-SS								
RGL20CE	20	6 ~ 8	24	12	2.5	6	M2	0.5
RGL20CE-SS								
RGL25CE	25	8 ~ 10	36	18	4.5	9	M2.5	1
RGL25CE-SS								
RGL32CE	32	10 ~ 14	45	20	4.0	10	M3	1.5
RGL32CE-SS								

### Technical Properties

Code	Rated torque	Max torque	Max speed	Moment of inertia	Weight
	N•m	N•m	rpm	Kg•m <sup>2</sup>	N•m/rad
RGL16CE	0.3	0.6	39000	3.4x10 <sup>-7</sup>	10
RGL16CE-SS				8.9x10 <sup>-7</sup>	25
RGL20CE	0.5	1	31000	9.2x10 <sup>-7</sup>	18
RGL20CE-SS				2.5x10 <sup>-6</sup>	45
RGL25CE	1	2	25000	3.4x10 <sup>-6</sup>	38
RGL25CE-SS				9.2x10 <sup>-6</sup>	100
RGL32CE	2	4	19000	1.0x10 <sup>-5</sup>	70
RGL32CE-SS				2.7x10 <sup>-5</sup>	180

※Note: Inertia moment and the weight are calculated as per the maximum aperture.If you need other dimensions, please feel free to contact us.



## RGS-CE Rigid coupling (OD from 16 to 32mm)



**Feature:**

- Light in weight, low inertia and high sensitivity
- Aluminum alloy and stainless steel are both available

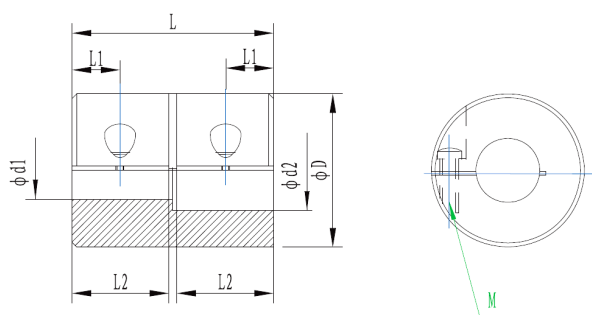

### Dimensions

Code	D	d1/d2	L	L1	L2	Clamp Screw	
	mm	mm	mm	mm	mm	Thread	Wrench Torque(N•m)
RGS16CE	16	5 ~ 6	16	3.75	7.5	M2.5	1.0
RGS16CE-SS							
RGS20CE	20	6 ~ 8	20	4.75	9.5	M2.5	1.0
RGS20CE-SS							
RGS25CE	25	8 ~ 10	25	6.0	12.0	M3	1.5
RGS25CE-SS							
RGS32CE	32	10 ~ 14	32	7.75	15.5	M4	2.5
RGS32CE-SS							

### Technical properties

Code	Rated torque	Max torque	Max speed	Moment of inertia	Weight
	N•m	N•m	rpm	Kg•m <sup>2</sup>	N•m/rad
RGS16CE	0.3	0.6	39000	3.2x10 <sup>-7</sup>	8.8
RGS16CE-SS				8.2x10 <sup>-7</sup>	22
RGS20CE	0.5	1	31000	8.7x10 <sup>-7</sup>	15
RGS20CE-SS				2.4x10 <sup>-6</sup>	41
RGS25CE	1	2	25000	2.7x10 <sup>-6</sup>	29
RGS25CE-SS				7.3x10 <sup>-6</sup>	80
RGS32CE	2	4	19000	9.3x10 <sup>-6</sup>	61
RGS32CE-SS				2.5x10 <sup>-5</sup>	160

※Note: Inertia moment and the weight are calculated as per the maximum aperture. If you need other dimensions, please feel free to contact us.

## **SCREW TECHNOLOGY CO.,LTD.**

Add:No 988,Wsong Road,Wuzhong Disrict,Suzhou,China

Tel: +86-0512-66903936

E-mail: [screwtech@screwtech.cn](mailto:screwtech@screwtech.cn)

Web: <http://www.screw-tech.com/>