



DAO-NS8102B(S)

DAO-NS8102

DAO-NS8102A(S)



9500 LBS Features and Specifications
 Single line rated pull: 9500lbs (4304kg)
 Motor: 5.8hp/4.3kw series -wound
 Braking action: Automatic locking with motor
 Clutch: Sliding ring gear
 Gear train : 3 -stage planetary
 Gear ratio: 216: 1
 Switch: Wire remote control with black hand bar ,
 Wireless remote control optional
 Fairlead: 4-way roller fairlead
 Weight: 80.6 pound (36.5kg)
 Steel cable: $\Phi 8.2 \times 85.4 \text{ ft}$ ($\Phi 8.2 \times 24 \text{ m}$)
 Weight: 80.6 pound (36.5kg)
 Overall dimension: 625mm x 220mm x 350mm
 Mounting bolt pattern: 10" x 4.5" (254mm x 114.3mm)

Line Speed And Amp Draw (First Layer)

Line Pull	lb	NO	4000	6000	8000	9500
	kg	LOAD	1812	2718	3624	4309
Line speed	ft/min	33.5	14.1	12.6	10.7	7.90
	m/min	11.74	4.29	3.84	3.08	2.50
Motor current	Amps	78	143	201	276	353

Line Pull And Cable Capacity

Layer of cable		1	2	3	4
Rated line pull per layer	lb	9500	7250	6125	5150
	kg	4304	3285	2775	2333
Length of cable on drum	ft	16.5	39.6	64.2	85.40
	m	5.03	12.70	19.57	26.00

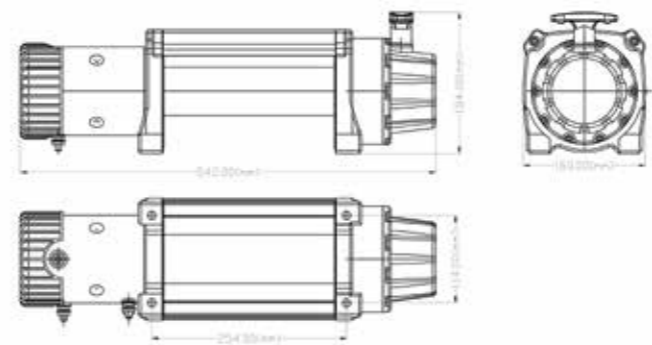



PHILOS PHOTOGRAPHY

DAO-NS8103

DAO-NS8103A(S)



DAO-NS8103B(S)

DAO-NS8103C(S)

12,000 LBS Features and Specifications:

Performance: 12 or 24 VDC

Single line rated pull: 12,000 lbs(5665kg)

Motor: 6 hp/5.0kw series -wound

Braking action: Automatic locking with motor

Clutch: Sliding ring gear

Gear train: 3 -stage planetary

Gear ratio: 216:1

Remote Switch: 11ft, wire remote control with black hand bar, wireless remote control included

Battery: Recommended: 650CCA minimum for winching

Battery Leads: 2 Gage 72" (1.83m)

Fairlead: 4-way roller fairlead

Rope: $\Phi 9.5 \times 72 \text{ ft}$ ($\Phi 9.5 \times 26.5 \text{ m}$)

Weight: 88 pound (40kg)

Overall dimension: 625mm x 220mm x 350mm

Mounting bolt pattern: 10" x 4.5" (254mm x 114.3mm)

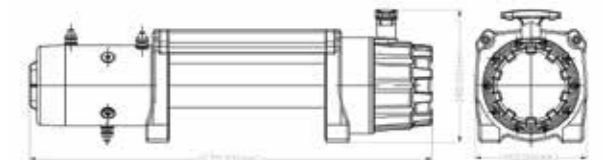



12,000lbs Features and Specifications :
 Performance: 12 /24 VDC
 Single line rated pull: 12,500lbs (5665kg)
 Motor: 6.6hp/5.0kw series –wound
 Braking action: Automatic locking with motor
 Clutch: Sliding ring gear
 Gear train : 3 –stage planetary
 Gear ratio: 265.2: 1
 Remote Switch: 11ft ,wire remote control with black hand bar , wireless remote control ready
 Battery: Recommended:650CCA minimum for winching
 Battery Leads: 2 Gauge 72”(1.83m)
 Fairlead: 4-way roller fairlead
 Steel cable: Φ 9.5 x 72 ft (Φ 9.5 x 24 m)
 Weight: 92.5 pound (42kg)
 Overall dimension: 650mm x 220mm x 350mm
 Mounting bolt pattern: 10” x 4.5” (254mm x 114.3mm)

Line Speed And Amp Draw (First Layer)

Line Pull	lb	NO	4000	6000	8000	9500	12500
	kg	LOAD	1812	2718	3624	4304	5665
Line speed	ft/min	22.8	11.8	10.2	8.5	7.0	6.0
	m/min	6.95	3.6	3.1	2.6	2.13	1.83
Motor current	Amps	78	166	207	248	310	372

Line Pull And Cable Capacity

Layer of cable		1	2	3	4
Rated line pull per layer	lb	12500	9927	8250	7045
	kg	5665	4497	3737	3191
Length of cable on drum	ft	17.8	38.2	64.2	72
	m	5.93	12.73	19.57	24.00

DAO-HW8104





DAO-HW8502



DAO-HW8502A(S)



DAO-HW8502B(S)

DAO-HW8502C(S)

12,500 LBS Features and Specifications :

Performance: 12 VDC
 Single line rated pull: 12,500lbs (4309kg)
 Motor: 7.2hp/5.5kw series –wound , fast speed
 Braking action: Automatic locking with motor
 Clutch: Rotating ring gear ,stainless T-clutch handle
 Gear train : 3 –stage planetary ,modules of 1.75 big gears ,all metal ,smooth weld planetary plate
 Gear ratio: 243: 1
 Remote Switch: 12ft ,wire remote control with black handbar , wireless remote control (optinal)
 Battery: Recommended:650CCA minimum for winching
 Battery Leads: 2 Gauge 72"(1.83m)
 Fairlead: 4-way roller fairlead (Forged hawse optional)
 Drum: 2.5"/8.8"(64mm x 224mm)
 Steel cable: 25/64" x 85" (Φ10 x 24.5 m)
 Weight: 103 pound (48kg)
 Overall dimension: 650mm x 260mm x 380mm
 Mounting bolt pattern: 10" x 4.5" (254mm x 114.3mm)

Line Speed And Amp Draw (First Layer)

Line Pull	lb	NO	4000	6000	8000	10000	12500
	kg	LOAD	1812	2718	3624	4304	4309
Line speed	ft/min	43.2	9.2	8.2	6.9	5.9	4.2
	m/min	13.2	2.8	2.5	2.1	1.9	1.3
Motor current	Amps	75	180	230	280	340	420

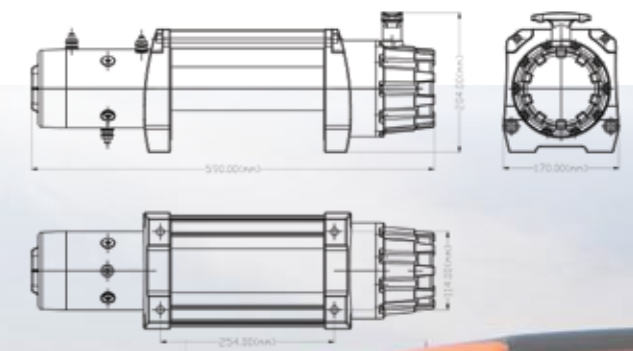



DAO-HW8505



DAO-HW8505A(S)



DAO-HW8505B(S)



DAO-HW8505C(S)

13,500 LBS Features and Specifications :

Performance: 12 VDC
 Single line rated pull: 13,500lbs (6116kg)
 Motor: 7.2hp/6.0kw series –wound , fast speed
 Braking action: Automatic locking with motor
 Clutch: Rotating ring gear ,stainless T-clutch handle
 Gear train : 3 –stage planetary ,all metal ,smooth weld planetary plate
 Gear ratio: 265: 1
 Remote Switch: 12ft ,wire remote control with black handbar , wireless remote control included
 Battery: Recommended:650CCA minimum for winching
 Battery Leads: 2 Gauge 72"(1.83m)
 Fairlead: 4-way roller fairlead (Forged hawse optional)
 Drum: 2.5"/8.8"(64mm x 224mm)
 Steel cable: 25/64" x 85" (Φ10 x 24.5 m)
 Weight: 105 pound (49kg)
 Overall dimension: 650mm x 260mm x 380mm
 Mounting bolt pattern: 10" x 4.5" (254mm x 114.3mm)

Line Speed And Amp Draw (First Layer)

Line Pull	lb	NO	4000	6000	8000	10000	13500
	kg	LOAD	1812	2718	3624	4304	6123
Line speed	ft/min	43.2	9.2	8.2	6.9	5.9	4.2
	m/min	13.2	2.8	2.5	2.1	1.9	1.3
Motor current	Amps	75	180	230	280	340	420

Line Pull And Cable Capacity

Layer of cable		1	2	3	4
Rated line pull per layer	lb	13500	10800	9000	7200
	kg	6116	4892	4077	3270
Length of cable on drum	ft	15.8	32.3	58.70	65.7
	m	5.21	10.70	19.30	21.80