

XPTN-9000-65-4GX16GT

MAIN FEATURES



**4*1000Base-X, 16*10/100/1000Base-T
Industrial Ethernet Switches**

Input Voltage: DC12~58V(Non-PoE),
DC48-58V(PoE)

Operating Temperature: -40°C ~ +75°C

Shell: IP40 protection, fanless design

Test Report: CCC, RoHS, FCC, CE

Anti-static: 8KV-15KV

MTBF: 100000 Hour

PRODUCT DESCRIPTION

This device is 4*1000Base-X & 16*10/100/1000Base-T Industrial Ethernet PoE Switches. Through the fanless heat dissipation circuit design, wide range of working environment temperature, high protection level and other technologies, it provides excellent industrial quality with high/low temperature resistance and lightning protection, and enhances the reliability and safety of industrial networks. It can better meet the deployment requirements of rail transit, safe city, intelligent transportation, outdoor monitoring and other harsh environments.

Scodena

PRODUCT PARAMETERS

Provider Mode Ports	
Fixed port	4*1000 Base-X, 16*10/100/1000Base-T
Power interface	Phoenix terminal, redundant dual power supply
LED Indicators	PWR, Link/ACT LED
Cable Type & Transmission Distance	
Twisted-pair	0-100m (CAT5e,CAT6)
Monomode optical fiber	20/40/60/80/100KM
Multimode (optical) fiber	550m
Network Topology	
Ring topology	Unsupported
Star topology	Support
Bus topology	Support
Tree Topology	Support
Hybrid topology	Support
Electrical Specifications	
Input voltage	DC12-58V (Non-PoE) , DC48~58V(PoE)
Total Power consumption	<26W(Non-PoE); <386W(PoE)
PoE Support (Optional)	
PoE port	1~16
PoE Protocol	802.3af, 802.3at
Pin Assignment	12+, 36-
PoE++ Support (Optional)	
PoE Port	1-16
PoE Protocol	802.3af, 802.3at, 802.3bt (Port 1 & Port 2 support 90W per port)
Pin Assignment	1245+, 3678-
Layer 2 Switching	
Switching capacity	68G
Packet forwarding rate	50.59Mpps
MAC address table	16K
Buffer	12M
Forwarding delay	<10us
MDX/MIDX	Support
Flow control	Support
Jumbo Frame	Support 10K Bytes
Environment	
Operating temperature	-40°C ~ +75°C The device is tested for 4 hours at temperatures in 85°C
Storage temperature	-40°C ~ +85°C
Relative humidity	5%~95% non-condensing
Thermal methods	Fanless, natural cooling
MTBF	100,000 hours

Mechanical Dimensions	
Product size	94*104*143mm
Installation Method	DIN rail
Weight	1KG around
EMC & Ingress Protection	
IP Level	IP40
Surge protection of Power	IEC 61000-4-5 Level X (6KV/6KV) (8/20us)
Surge protection of Ethernet port	IEC 61000-4-5 Level X (4KV/4KV) (10/700us)
RS	IEC 61000-4-3 Level 3 (10V/m)
EFI	IEC 61000-4-4 Level 3 (1V/2V)
CS	IEC 61000-4-6 Level 3 (10V/m)
PFMF	IEC 61000-4-8 Level 4 (30A/m)
DIP	IEC 61000-4-11 Level 3 (10V)
ESD	IEC 61000-4-2 Level 4 (8K/15K)
Free fall	0.5m
Authentication	
Authentication	CCC, CE, FCC, RoHS
Accessories	
Accessories	Device, Terminals, Specification, Certificate, power adapter(optional)
Optional model	
XPTN-9000-65-4GX16GT	4*1000Mbps SFP Port 16*10/100/1000Mbps RJ45 Port
XPTN-9000-65-4GX16GP	4*1000Mbps SFP Port 16*10/100/1000Mbps RJ45 Port, PoE & PoE+
XPTN-9000-65-4GX16GPB	4*1000Mbps SFP Port 16*10/100/1000Mbps RJ45 Port, PoE & PoE+, 2 Port support++

SIZE AND APPEARANCE

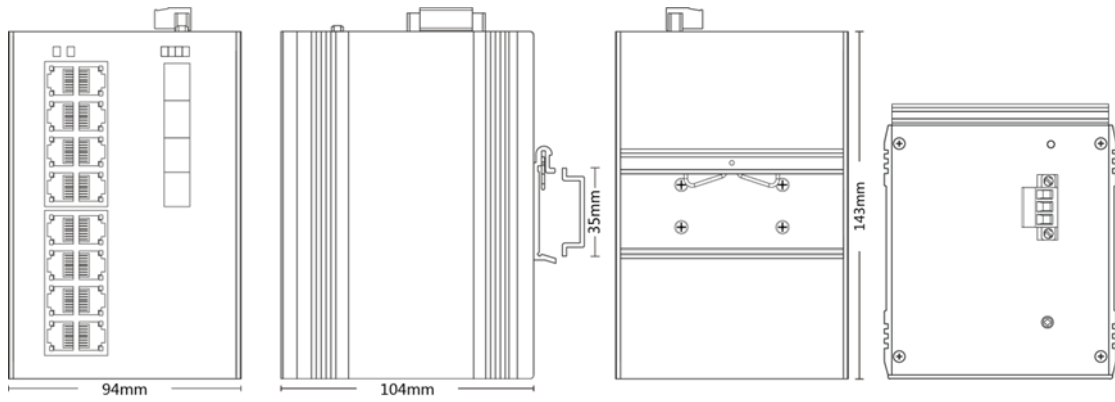

Front view

Side view

Back view

Top view