

# XPTN-9000-63-1GX1GT

## MAIN FEATURES



**1\*1000Base-X, 1\*10/100/1000Base-T  
Industrial Ethernet Switches**

**Input Voltage:** DC12-58V

**Operating Temperature:** -40°C ~ +75°C

**Shell:** IP40 protection, fanless design

**Test Report:** CCC, RoHS, FCC, CE

**Anti-static:** 8KV-15KV

**MTBF:** 100000 Hour

## PRODUCT DESCRIPTION

This device is 1\* 1000Base-X & 1\*10/100/1000Base-T Industrial Ethernet Switches. Through the fanless heat dissipation circuit design, wide range of working environment temperature, high protection level and other technologies, it provides excellent industrial quality with high/low temperature resistance and lightning protection, and enhances the reliability and safety of industrial networks. It can better meet the deployment requirements of rail transit, safe city, intelligent transportation, outdoor monitoring and other harsh environments.

***Scodena***

# PRODUCT PARAMETERS

<b>Provider Mode Ports</b>	
Fixed port	1*1000 Base-X, 1*10/100/1000Base-T
Power interface	Phoenix terminal, redundant dual power supply
LED Indicators	PWR, OPT ,NMC, ALM
<b>DIP Switch</b>	
1 C/D	Reserve
2 LGY	Reserve
3 VLAN	Port Isolation
4 RST	Reset
<b>Cable Type &amp; Transmission Distance</b>	
Twisted-pair	0-100m (CAT5e,CAT6)
Monomode optical fiber	20/40/60/80/100KM
Multimode (optical) fiber	550m
<b>Network Topology</b>	
Ring topology	Unsupported
Star topology	Support
Bus topology	Support
Tree Topology	Support
Hybrid topology	Support
<b>Electrical Specifications</b>	
Input voltage	DC12-58V
Total Power consumption	<6W
Voltage Alarm	Support
<b>Layer 2 Switching</b>	
Switching capacity	14G
Packet forwarding rate	10.416Mpps
MAC address table	8K
Buffer	1M
Forwarding delay	<5us
MDX/MIDX	Support
Flow control	Support
Jumbo Frame	Support 10Kbytes
WatchDog	Support
Port Isolation	Support
<b>Environment</b>	
Operating temperature	-40°C~ +75°C The device is tested for 4 hours at temperatures in 85°C
Storage temperature	-40°C~ +85°C
Relative humidity	5%~95% non-condensing
Thermal methods	Fanless, natural cooling
MTBF	100,000 hours
<b>Mechanical Dimensions</b>	

Product size	143X104X48mm
Installation Method	DIN rail
Weight	0.6KG around
<b>EMC &amp; Ingress Protection</b>	
IP Level	IP40
Surge protection of Power	IEC 61000-4-5 Level X (6KV/6KV) (8/20us)
Surge protection of Ethernet port	IEC 61000-4-5 Level X (4KV/4KV) (10/700us)
RS	IEC 61000-4-3 Level 3 (10V/m)
EFI	IEC 61000-4-4 Level 3 (1V/2V)
CS	IEC 61000-4-6 Level 3 (10V/m)
PFMF	IEC 61000-4-8 Level 4 (30A/m)
DIP	IEC 61000-4-11 Level 3 (10V)
ESD	IEC 61000-4-2 Level 4 (8K/15K)
Free fall	0.5m
<b>Authentication</b>	
Authentication	CCC, CE, FCC, RoHS
<b>Accessories</b>	
Accessories	Device, Terminals, Specification, Certificate, power adapter(optional)
<b>Optional model</b>	
XPTN-9000-63-1GX1GP	1*1000Mbps SFP Port, 2*10/100/1000Mbps RJ45 Port, PoE 802.3af & at
XPTN-9000-63-1GX1GP-SC	1*100Mbps SC Port 2*10/100/1000Mbps RJ45 Port, PoE 802.3af & at
XPTN-9000-63-1GX1GP-FC	1*1000Mbps FC Port 2*10/100/1000Mbps RJ45 Port, PoE 802.3af & at
XPTN-9000-63-1GX1GP-ST	1*1000Mbps ST Port 2*10/100/1000Mbps RJ45 Port, PoE 802.3af & at

**Scodena**

# SIZE AND APPEARANCE

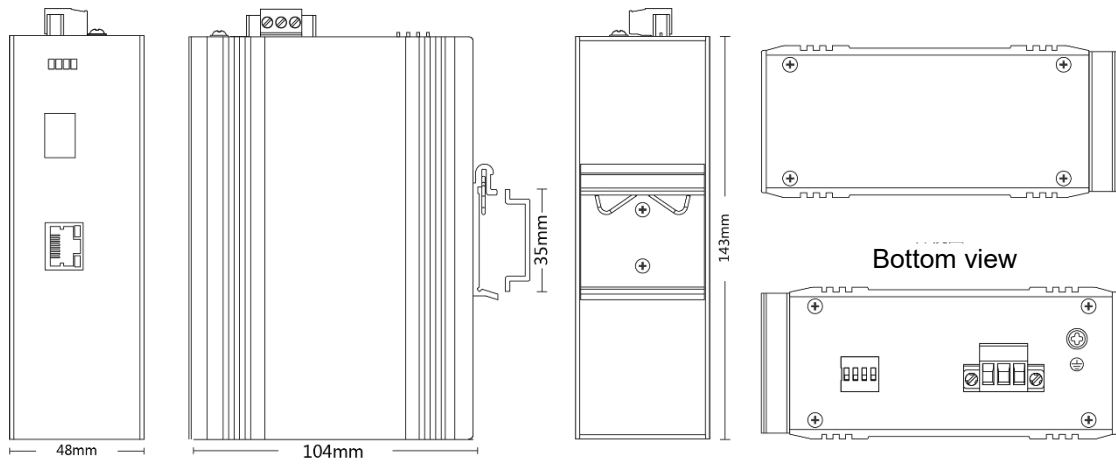

Front view

Side view

Back view

Top view