

XPTN-9000-85-4GX24GP-VX

MAIN FEATURES



4*1000Base-X, 24*10/100/1000Base-T Managed Industrial PoE Switches

Input Voltage: DC12-58V(Non-PoE),
DC48~58V(PoE)

Operating Temperature: -40°C~ +75°C

Shell: IP50 protection, fanless design

Test Report: CCC, RoHS, FCC, CE

Anti-static: 8KV-15KV

MTBF: 100000 Hours

PRODUCT DESCRIPTION

The device is 4*1000Base-X, 24*10/100/1000Base-T Managed PoE Industrial Ethernet switch, through the fanless cooling circuit design, wide range working environment temperature, high protection level and other technologies, provide high / low temperature, lightning protection and other outstanding industrial quality, and integrated switching, safety and various rich protocols, simultaneously supported The public Ethernet multi ring protection technology (ERPS) has greatly enhanced the flexibility of the network and enhanced the reliability and security of the industrial network. It can meet the deployment requirements of rail transit, safe city, intelligent transportation, outdoor monitoring and other harsh environments.

PRODUCT PARAMETERS

Provider Mode Ports

Fixed port

4*1000Base-X, 24*10/100/1000 Base-T

Scodena

| | |
|---|---|
| Management Port | Support console |
| Power interface | Phoenix terminal, redundant dual power supply |
| LED Indicators | PWR, Link/ACT LED |
| Cable Type & Transmission Distance | |
| Twisted-pair | 0-100m (CAT5e,CAT6) |
| Monomode optical fiber | 20/40/60/80/100KM |
| Multimode (optical) fiber | 550m |
| Network Topology | |
| Ring topology | Support |
| Star topology | Support |
| Bus topology | Support |
| Tree Topology | Support |
| Hybrid topology | Support |
| Electrical Specifications | |
| Input voltage | DC12-58V(Non-PoE), DC48-58V(PoE) |
| Total Power consumption | < 26W(Non-PoE), <386W(PoE) |
| PoE Support | |
| PoE port | 1-24 |
| PoE Protocol | 802.3af, 802.3at |
| Pin Assignment | 1,2,3,6 |
| PoE Management | Support |
| Layer 2 Switching | |
| Switching capacity | 68G |
| Packet forwarding rate | 50.59Mpps |
| MAC address table | 16K |
| VLAN | Support 4K |
| Buffer | 12M |
| Forwarding delay | <10us |
| MDX/MIDX | Support |
| Flow control | Support |
| Jumbo Frame | Support 10Kbytes |
| Spanning Tree | Support STP/RSTP/MSTP |
| Ring Protocol | Support ERPS |
| Link Aggregation | Support 12 group |
| Multicast | Support IGMP Snooping |
| Port Mirroring | Support |
| Storm Control | Support |
| Interface Counters | Support |
| QINQ | Support |
| WatchDog | Support |
| 802.1X | Support |
| MAC Authentication | Support |
| Port Isolation | Support |
| Rmon | Support |
| NTP client | Support |

| | |
|-------------------------------------|--|
| DHCP client | Support |
| DHCP snooping | Support |
| DHCP CLIENT | Support |
| PING/TRACEROUT | Support |
| Dying gasp | Support |
| DDM | Support |
| Convergence | |
| ACL | Support ACL 500 Support IP standard ACL Support MAC expand ACL Support IP expand ACL |
| QOS | Support QoS re-marking, priority mapping Support SP, WRR queue scheduling Support egress rate-limited, egress rate-limit Support Policy-based QoS |
| Management | |
| CLI | Support |
| Console | Support |
| Telnet | Support |
| WEB management | Support |
| Management IP | Support IPV4/IPV6 |
| SNMP | Support SNMPv1/v2c/v3 |
| User Management | Support |
| System Log | Support |
| Configuration File Download/Upload | Support |
| Upgrade Firmware | Support |
| Environment | |
| Operating temperature | -40°C~+75°C The device is tested for 8 hours at temperatures in 85°C |
| Storage temperature | -40°C~+85°C |
| Relative humidity | 5%~95% (non-condensing) |
| Thermal methods | Fanless design |
| MTBF | 100,000 hours |
| Mechanical Dimensions | |
| Product size | 143*104*108mm |
| Installation Method | DIN-rail |
| Weight | 1.3KG |
| EMC & Ingress protection | |
| IP Level | IP50 |
| Surge protection of Power | IEC 61000-4-5 Level X (6KV/6KV) (8/20us) |
| Surge protection of Ethernet port | IEC 61000-4-5 Level X (4KV/4KV) (10/700us) |
| RS | IEC 61000-4-3 Level 3 (10V/m) |
| EFI | IEC 61000-4-4 Level 3 (1V/2V) |
| CS | IEC 61000-4-6 Level 3 (10V/m) |
| PFMF | IEC 61000-4-8 Level 4 (30A/m) |
| DIP | IEC 61000-4-11 Level 3 (10V) |

| | |
|-------------------------|--|
| ESD | IEC 61000-4-2 Level 4 (8K/15K) |
| Free fall | 0.5m |
| Authentication | |
| Authentication | CCC/CE/FCC/RoHS |
| Accessories | |
| Accessories | Device, Terminals, Specification, Certificate Adapter (Optional) |
| Optional Model | |
| XPTN-9000-85-4GX24GT-VX | 4*1000Mbps SFP Port, 24*10/100/1000Mbps RJ45 Port |

SIZE AND APPEARANCE

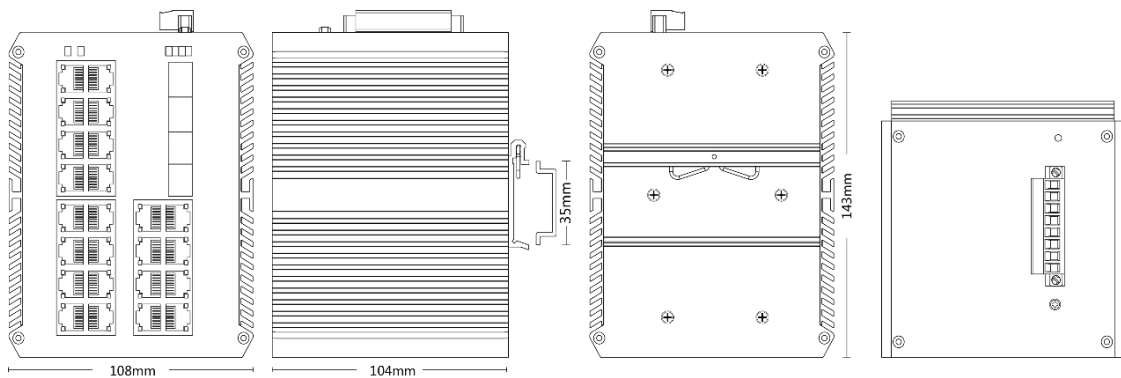

Front view

Side view

Back view

Top view