



Company profile



THIS CATALOG IS DESIGNED TO PROVIDE BASIC INFORMATION ONLY
PLEASE CONTACT OUR SALESMAN FOR FURTHER INFORMATION AND OPERATING INSTRUCTIONS



SGS



**OHSAS
18001**



NBV Profile-03
Copyright 2016
ALL Rights Reserved

NINGBO FLK TECHNOLOGY CO.,LTD

Add:No. 666 JinYuan Road, PanHuo Sub-District YinZhou ,Ningbo,China 315104
Tel:MECHANICAL SEALS(+86-574-83098019/88217079) CHEM RING(+86-574-88217655)
SILICON CARBIDE(+86-574-83098020) WAVE SPRING(+86-574-88217655)
E-mail:info@sealmann.com Fax:+86-574-88210066 Website:www.sealmann.com

Distributed by:

NINGBO FLK
[Http://www.sealmann.com](http://www.sealmann.com)

Brief Introduction

Ningbo FLK Technology Co. Ltd as the high-tech enterprise has integrated R&D, manufacture, sales and service into our series of products: engineering ceramics, mechanical seals, seal auxiliary systems, encapsulated O-rings, wave springs etc. And we initiated drafting and making several state and industry standards.

Our products under the trademark “FLK” are widely used in the fields of petroleum, chemical industry, ship, water treatment, steel, power, paper making, food, military and aerospace etc.

Adhering to our management idea “People oriented, technological innovation and continuous improvement”, we established and implemented full-procedure control and service system in line with customer requirements, and widely accepted by customers.



Technological Innovation



The full study and evaluation of customer's expectations and market trends is the basis of our innovation and development. This ensures that the focus of our research and development is to meet the increasing demands of our customers.

We invests 5% to 8% sales revenues in R&D, and we work closely with our customers and research institutions which makes our R&D possible to meet the challenges from multiple angles.



We continually invests in and improves lean manufacturing, automation, environmental protection and information technology etc, which makes our products more reliable and costs much lower for customers .

We continually invests in and improves the areas of manufacturing, quality control and product verification to make our products more reliable and cost-effective.



Mechanical Seals

Mechanical seals under “FLK” trademark, apply the advanced design concepts and the latest achievement of material development and have been proven by large number of successful applications, through the advanced manufacturing technics, testing methods and strict quality assurance system and efficient service support, with the characteristics of high reliability, high stability, long life, and high performance cost ratio. “SEALMANN” has become the first choice for customers.



Seal Auxiliary Systems

Auxiliary systems under “FLK” trademark, mainly used in series of solutions for API 682 standard (PLAN21, 31, 52, 53A, 53B and 53C etc..), with products of reservoir, hydraulic cyclone separator, heat exchanger etc. Different kinds of gauges and switches can be equipped for monitor or alarm as required.

Our goal is to provide customers with more reliable product solutions to ensure that the mechanical seals are running under a safe, stable, long-term reliable environment.



Ceramic Bearing

Ceramic bearing under “FLK” trademark, adopts advanced ceramic processing technology and can provide ceramic bearings in various materials, which are widely used in mechanical facilities like magnetic drive pumps, canned motor pumps, multistage pumps, submersible pump, chemical pumps, centrifuges and valves etc.

We can develop various bearings of high-parameter, high-precision & high-performance in different ceramic materials and carbon as specified by customers.



Seal Ring

Seal rings under “FLK” trademark, have the advanced powder preparation technology with independent intellectual property rights, with various molding technologies such as dry pressing, isostatic pressing, squeezing & flow casting and different sintering technologies such as pressureless, hot-pressing, reaction. We can supply our customers with high performance cost ratio and high quality seal rings in various materials such as silicon carbide, nitride carbide, zirconia, aluminum oxide and tungsten carbide. This series of seal rings are widely used in the fields of machinery, petroleum, chemical industry, water treatment, aerospace, ship, metallurgy and nuclear power etc.



Kiln furniture

Kiln furniture under “FLK” trademark, has initiated the using of pressureless sintered silicone carbide kiln furniture products, with prominent advantages like withstanding 1600 degrees of high temperature, no residue, energy efficiency and environmental protection. “FLK” has become the ideal choice for enterprises of the domestic high-end daily ceramic products.

This series of products include column, square & round beam, plate etc and thin rod & tube specifically used & hung for burning spoon and small pendants. They are particularly suitable for using in shuttle kiln, tunnel kiln & roller kiln with sintering temperature over 1300 degrees. They are also the first choice for high temperature heat exchanger.



product dimensions (Unit: mm)



◀ **Pillar**
OD:45, 50
Wall thickness: 4.5, 5.0
Length: 500-1500

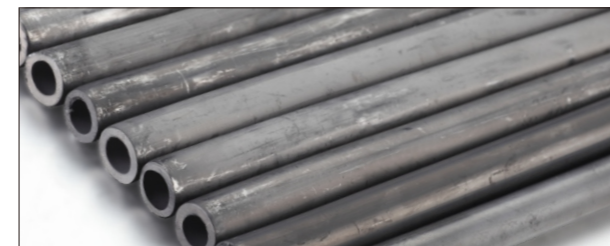

◀ **Circular tube Dimensions:**
OD: 6, 8, 10, 12, 15;
Wall thickness: 0.8, 1.0, 1.2, 1.5, 2.0, 2.5
Length: 500, 550, 600, 650, 700, 750



◀ **Square tube Dimensions:**
Side length: 6, 8, 10;
Wall thickness :0.8,1.0,1.2,1.5,2.0,2.5;
Length: 500, 550, 600, 650, 700, 750

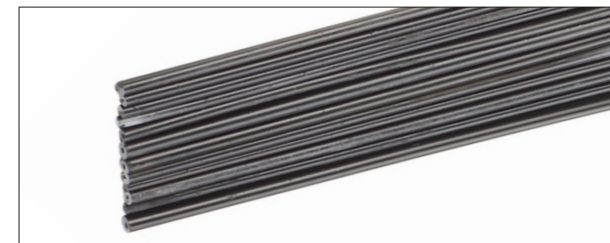

◀ **Thin tube Thin Roller Dimensions:**
OD: 2.5,3.0,3.5 ;
Length: 125,130,135,140,145,150;



◀ **Plate Dimensions:**
OD/ID 80/20,100/30,120/50,140/70,160/80,180/90;
Thickness: 1.0,1.5,2.0,2.5,3.0,3.5;

Armor Materials

Armor materials under “FLK” trademark, are available in various materials such as reaction, pressureless & hot-pressing sintered silicone carbide and boron carbide, and aluminum oxide etc, with different shapes of products for selection by customers.

This series of products are widely used for protection of body, vehicle armor, specialized building and various specialized vehicles.

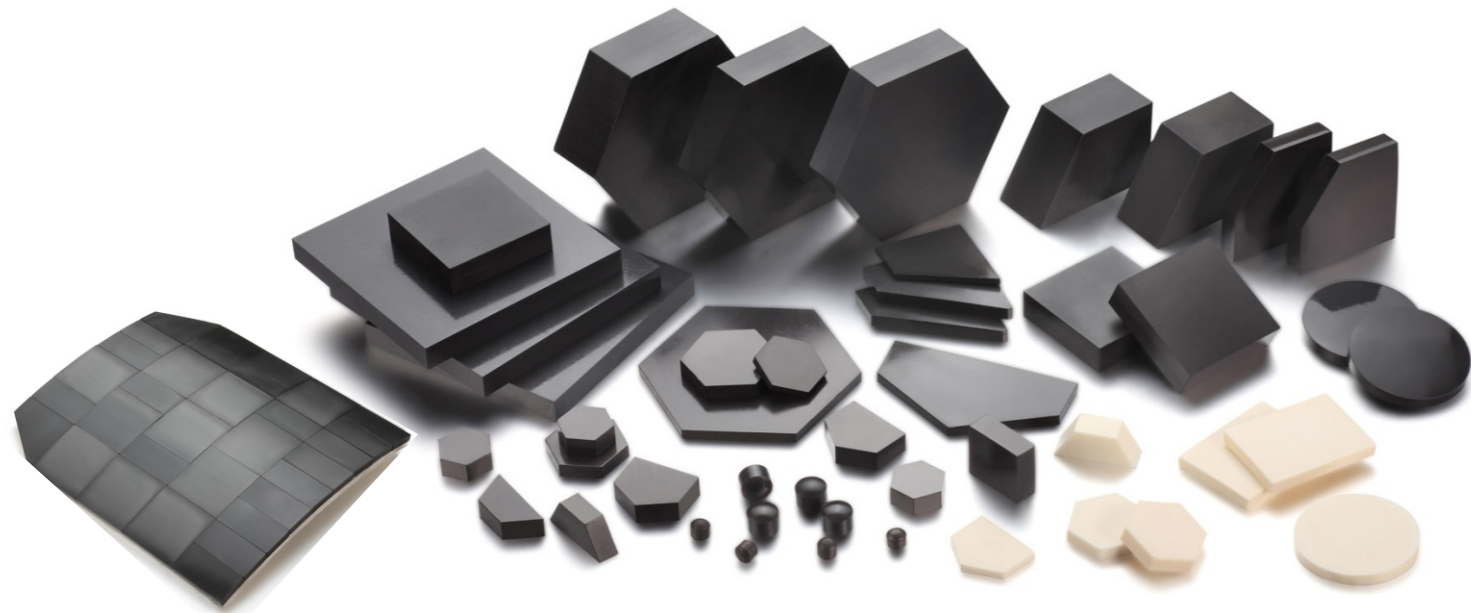

Nozzle

Nozzle under “FLK” trademark, is available from different sizes in various materials such as reaction, pressureless & hot-pressing sintered silicone carbide and boron carbide, aluminum oxide, zirconia and tungsten carbide etc.

This series of nozzle is widely used in machinery equipments for surface cleaning and surface strengthening in the fields of machinery, petroleum, chemical industry, automobile, metallurgy, aerospace, ship-building, glass, coal etc.



Ceramic Cutting Tool

Ceramic cutting tool under “FLK” trademark, is available in materials of silicon nitride and titanium carbonitride. This series of cutting tool has good shock resistance, heat resistance, inoxidizability and excellent cutting performance. Our tools' cutting speed is 3-10 times faster than tool made from tungsten carbide. It is capable of high-speed cutting and dry cutting which greatly improves efficiency and cost of production.



Teflon Encapsulated O-Ring

Teflon encapsulated O-rings under “FLK” trademark, are available in FEP and PFA for encapsulation material and fluoro rubber and silicone rubber for core material, with characteristics of great corrosion resistance, compliance of environmental and hygienic requirements and suitability for wide range of working temperatures, plus excellent sealing performance and durability for almost all chemical media. They are widely used in pumps, valves, filters, medical equipment, chemical containers, pipe flanges and mechanical seals etc.

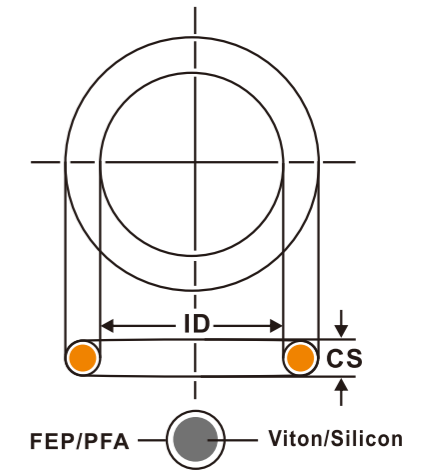

Wave spring under “FLK” trademark, can effectively compensate the assembly dimensional deviation to meet a variety of static and dynamic operating requirements.

Wave springs can fit into assemblies that other springs can not. They are easy to install, can save space and total cost of the assembled equipment. They can be widely used in valves, compressors, clutch, braking system, railway transportation and mechanical seals etc.

- FLK High load、High strength
- FLK Compact assembly space
- FLK Reduced noise
- FLK Decreased vibration

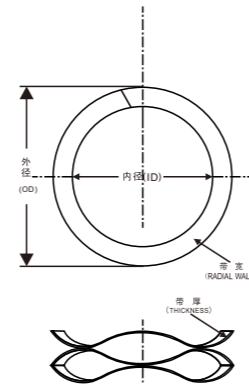
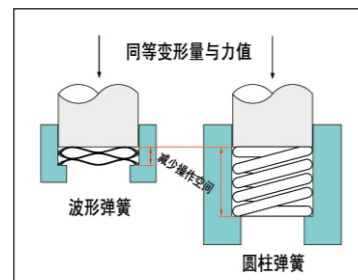

We guarantee all direct users of all-around support, including technical consulting, solutions and product upgrading.



More than 5 million parts on our dynamic inventory available for fast delivery service



We always stick to the 24-hour service commitment, to maximize customer service.

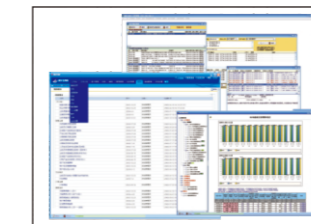

Customer with strategic agreement and authorization can check inventory, order progress online at anytime.



Exclusive 40million RMB product quality bond insurance in China, valid globally and further remove the user's worries.