

EV LIGHT[®]

EV-S400



User Manual

Please read the instructions carefully

TABLE OF CONTENTS

1. Safety Instructions
2. Technical Specifications
3. Installation
4. How to set the unit
5. How to control the unit
6. DMX512 Configuration
7. DMX512 Connections
8. Troubleshooting
9. Fixture Cleaning

1. Safety Introductions



WARNING

Please read the instructions carefully which includes important information about the installation, operation and maintenance.

Please keep this User Manual for future consultation. If you sell the fixture to another user, be sure that they also receive this instruction booklet.

Unpack and check carefully there is no transportation damage before using the fixture. It's important to ground the yellow/green conductor to earth in order to avoid electric shock.

Disconnect main power before servicing and maintenance.

The unit must be installed in a location with adequate ventilation, at least 50cm from adjacent surfaces. Be sure that no ventilation slots are blocked.

Maximum ambient temperature is $T_a : 40^{\circ}\text{C}$. Don't operate it where the temperature is higher than this.

Unit surface temperature may reach up to 85°C . Don't touch the housing bare-hand during its operation. Turn off the power and allow about 15 minutes for the unit to cool down before replacing or serving.

In the event of serious operating problem, stop using the fixture immediately. Never try to repair the fixture by yourself. Repairs carried out by unskilled people can lead to damage or malfunction. Please contact the nearest authorized technical assistance center. Always use the same type spare parts.

Do not connect the device to any dimmer pack.

Do not touch any wire during operation and there might be a hazard of electric shock.

To prevent or reduce the risk of electrical shock or fire, do not expose the fixture to rain or moisture.

The housing must be replaced if they are visibly damaged.

Do not look directly at the LED light beam while the fixture is on.

There are no user serviceable parts inside the fixture. Do not open the housing or attempt any repairs by yourself. In the unlikely event your fixture may require service, please contact your nearest dealer.

Due to the magnifying type lens, please keep the lens out of contact with direct sunlight. Direct sunlight can cause heat to build up inside of the unit, which will seriously damage unit.

2. Technical Specifications

- DMX 4CH/10CH channels switchable.
- Smooth 0~100% dimming and variable strobe speeds.
- Three operation modes: DMX, Master/Slave mode, Sound Active.
- Ideal for discotheques, clubs, bars, parties, Mobile DJs, ect.
- Power Supply: 120~230V 50/60Hz
- Power consumption:300W
- LED: 36PCS cree 4in1LED
- Dimension: 602* 214* 227mm
- Weight:9.2 kgs

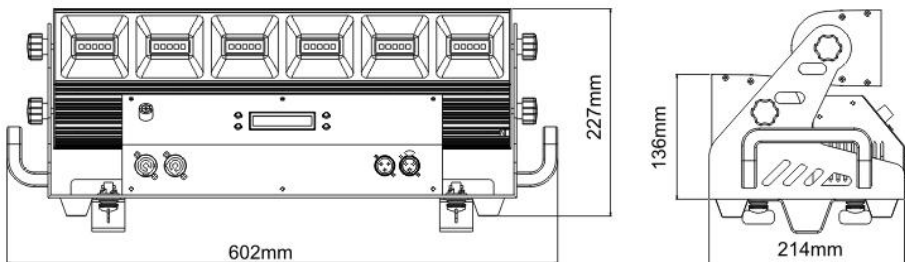

3. Installation

The unit should be mounted via its screw holes on the bracket. Always ensure that the unit is firmly fixed to avoid vibration and slipping while operating. Always ensure that the structure to which you are attaching the unit is secure and is able to support a weight of 10 times of the unit's weight. Also always use a safety cable that can hold 12 times of the weight of the unit when installing the fixture.

The equipment must be fixed by professionals. And it must be fixed at a place where is out of the touch of people and has no one pass by or under it, the range of mounting height is 0~30 M.

4. How to set the unit

4.1 Rear Panel

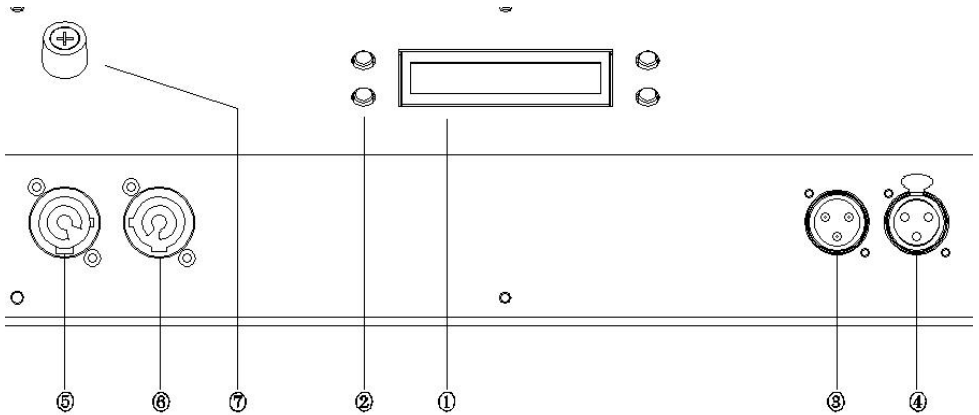

① **Display:** To show the various menus and the selected functions

LED:

DMX	On	DMX input present
MASTER	On	Master Mode
SLAVE	On	Slave Mode
SOUND	Flashing	Sound activation

② Button:

MENU	To select the programming functions with short press.
DOWN	To go backward in the selected functions
UP	To go forward in the selected functions
ENTER	To confirm the selected functions

③ **DMX input:** For DMX512 link, use 3/5-pin XLR plug cable to input DMX signal.

④ **DMX output:** For DMX512 link, use 3/5-pin XLR plug cable to link the next unit.

⑤ **POWER input:** Connect to supply mains power.

⑥ **POWER output:** Receive music for the sound active.

⑦ **FUSE:**

4.2 Main Function

To select any functions, press **MENU** button until the required one is shown on the display. Select the function by **ENTER** button and the display will blink. Use **DOWN** and **UP** button to change the mode. Once the required mode has been selected, press **ENTER** button to setup or it will automatically return to the main functions without any change after idling 30 seconds. Back to the functions without any change press **MENU** button. The main functions are shown below:

DMX Address	1-512
Channel Mode	4 CH 10 CH
Slave Mode	Master Slave 1- Slave 15
Show Mode	Show0~Show4
Blackout	Yes/N0
Back Light	On - Off
Auto Test	
Fixture temp	
Fixture Time	Fixture hours 0 ~ 9999
Version	V 10

DMX Address

Press the **MENU** button up to when the **DMX Address** is shown on the display. Pressing the **ENTER** button and the display will blink. Use the **DOWN** and **UP** button to change the DMX 512 address. Once the address has been selected, press the **ENTER** button to setup or automatically exit menu mode without any change after 7 seconds. Back to the previous functions without any change press the **MENU** button.

Channel Mode

Press the **MENU** button up to when the **Channel Mode** is shown on the display. Pressing the **ENTER** button, Use the **DOWN** and **UP** button to select the (1 channel) or (2 channels) or (4 channels) or (12 channels) or (14 channels) or (16 Channels) mode. Once selected, press the **ENTER** button to setup or automatically exit menu mode without any change after 7 seconds. To go back to the functions without any change press the **MENU** button

Slave Mode

Press the **MENU** button up to when the **Slave Mode** is shown on the display. Pressing the **ENTER** button, Use the **DOWN** and **UP** button to select the (slave 1) or (Slave 2) ... or (Slave 15) mode. Once selected, press the **ENTER** button to setup or automatically exit menu mode without any change after 7 seconds. To go back to the functions without any change press the **MENU** button.

Show Mode

Press the **MENU** button up to when the **Show Mode** is shown on the display. Pressing the **ENTER** button, Use the **DOWN** and **UP** button to select the **Show0** (Random show) or **Show1** (show 1) or **Show2** (Show 2) or ... or **Manual** (Manual). Once selected, press the **ENTER** button to store or automatically exit menu mode without any change after 7 seconds. To go back to the functions without any change press the **MENU** button

Manual Mode

Press the **MENU** button up to when the **Manual Mode** is shown on the display. Pressing the **ENTER** button, Use the **DOWN** and **UP** button to select the **strobe** (strobe) or **dimmer** (dimmer). Once selected **strobe**, Pressing the **ENTER** button, Use the **DOWN** and **UP** button to change the strobe 0 – 255. Once selected, press the **ENTER** button to store. If you select **dimmer**, Pressing the **ENTER** button, Use the **DOWN** and **UP** button to change the

dimmer 0 – 255, Once selected, press the **ENTER** button to setup or automatically exit menu mode without any change after 60 seconds. To go back to the functions without any change press the **MENU** button

Sound State

Select **Sound State**, press the **ENTER** button to confirm, present mode will blink on the display. Use the **DOWN** and **UP** button to select the **On** (sound on) or **Off** (sound off) mode. Once the mode has been selected, press the **ENTER** button to setup, to go back to the functions without any change press the **MENU** button again. Hold and press the **MENU** button about one second or wait for one minute to exit the menu mode.

Sound Sense

Press the **MENU** button up to when the **Sound Sense** is shown on the display. Press the **ENTER** button and the display will blink. Use the **DOWN** and **UP** buttons to adjust the sound sensitively (0-100) of the unit. Once selected, press the **ENTER** button to setup or automatically exit menu mode without any change after 7 seconds. To go back to the functions without any change press the **MENU** button.

Blackout Mode

Press the **MENU** button up to when the **Blackout Mode** is shown on the display. Pressing the **ENTER** button, Use the **DOWN** and **UP** button to select the **yes** (blackout) or **no** (normal). Once selected, press the **ENTER** button to setup or automatically exit menu mode without any change after 7 seconds. To go back to the functions without any change press the **MENU** button.

Back Light

Select **Back Light**, press the **ENTER** button to confirm, present mode will blink on the display. Use the **DOWN** and **UP** button to select the **On** (Led on) or **Off** (Led off) mode. Once the mode has been selected, press the **ENTER** button to setup, to go back to the functions without any change press the **MENU** button again. Hold and press the **MENU** button about one second or wait for one minute

Auto-Test

Press the **MENU** button up to when the **Auto-Test** is blinking on the display. Pressing **ENTER** button and the unit will run self-test by built-in program. To go back to the functions press the **MENU** button again. Hold and press the **MENU** button about one second or wait for one minute to exit the menu mode.

Fixture Time

Press the **MENU** button up to when the **Fixture Time** is blinking on the display. Pressing **ENTER** button and the display will show the number of working hours of the unit. To go back to the functions press the **MENU** button again. Hold and press the **MENU** button about one second or wait for one minute to exit the menu mode.

Firmware Version

Press the **MENU** button up to when the **Firmware version** is blinking on the display. Pressing **ENTER** button and the display will show the version of software of the unit. To go back to the functions press the **MENU** button again. Hold and press the **MENU** button about one second or wait for one minute to exit the menu mode.

5. How To Control The Unit

You can operate the unit in three ways:

1. By master/slave built-in preprogram function
2. By easy controller
3. By DMX controller

No need to turn the unit off when you change the DMX address, as new DMX address setting will be affected at once. Each time you turn the unit on, it will show "M312" on the display. After that the unit will be ready to receive DMX signal or run the built in programs.

5.1 Master/Slave Built In Preprogrammed Function

By linking the units in master/slave connection, the first unit will control the other units to give an automatic, sound activated, synchronized light show. This function is good when you want an instant show. You have to set the first unit in master mode and select **Show0**

(random show), **Show1** (show 1) or ...or **Show8** (show 8). Its DMX input jack will have nothing plugged into it, and Its master LED will be constantly on and sound LED will flash to the music.

5.2 DMX Controller

Using universal DMX controller to control the units, you have to set DMX address from 1 to 512 channel so that the units can receive DMX signal.

Press the **MENU** button up to when the **DMX Address** is showing on the display. Pressing **ENTER** button and the display will blink. Use **DOWN** and **UP** button to change the DMX512 address. Once the address has been selected, press and keep **ENTER** button pressed up to when the display stops blinking or storing automatically 8 seconds later. To go back to the functions without any change press the **MENU** button again. If you use please refer to the following diagram to address your DMX512 channel for the first 4 /2 units.

Channel Mode	Unit 1	Unit 2	Unit 3	Unit 4
4 Channel	1	5	9	13
10 Channel	1	11	21	31

6. DMX512 Configuration

4-CH mode:

CH1	Red	000-255	0%-100%
CH2	Green	000-255	0%-100%
CH3	Blue	000-255	0%-100%
CH4	white	000-255	0%-100%

10-CH mode:

CH1	Red	000-255	0%-100%
CH2	Green	000-255	0%-100%
CH3	Blue	000-255	0%-100%
CH4	white	000-255	0%-100%
CH5	Red	000-255	0%-100%
CH6	Green	000-255	0%-100%
CH7	Blue	000-255	0%-100%
CH8	white	000-255	0%-100%
CH9	Dimmer	000-255	0%-100%
CH10	Strobe	000-255	0%-100%

7. DMX512 Connections

mode connection:



Termination reduces signal errors and to avoid signal transmission problems and interference. It is always advisable to connect a DXM terminal. (Resistance 120 ohm 1/4W) between pin2(DXM-) and pin3(DXM+) of the last fixture.

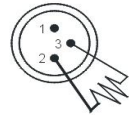

1. Connect the fixture together in a “daisy chain” by XLR plug cable from the output of the fixture to the input of the next fixture. The cable cannot be branched or split to a “Y” cable. Inadequate or damaged cables, soldered joints or corroded connectors can easily distort the signal and shut down the system.
2. The DMX output and input connectors are pass-through to maintain the DMX circuit when one of the units’ power is disconnected.
3. At last fixture, the DMX cable has to be terminated with a terminator to reduce signal errors. Solder a 120-ohm 1/4W resistor between pin 2(DMX-) and pin 3(DMX+) into a 3-pin XLR-plug and plug it in the DMX-output of the last fixture.
4. Each lighting fixture needs to have an address set to receive the data sent by the controller. The address number is between 0-511 (usually 0 & 1 are equal to 1).
5. 3 pin XLR connectors are more popular than 5 pins XLR.
3 pin XLR: Pin 1: GND, Pin 2: Negative signal (-), Pin 3: Positive signal (+)
5 pin XLR: Pin 1: GND, Pin 2: Negative signal (-), Pin 3: Positive signal (+), Pin4/5: not used

8. Troubleshooting

Following are a few common problems that may occur during operation. Here are some suggestions for easy troubleshooting:

A. The fixture does not work, no light

1. Check the connection of power and main fuse.

2. Measure the mains voltage on the main connector.

B. Not responding to DMX controller

1. DMX LED should be on. If not, check DMX connectors, cables to see if link properly.
2. If the DMX LED is on and no response to the channel, check the address settings and DMX polarity.
3. If you have intermittent DMX signal problems, check the pins on connectors or on PCB of the fixture or the previous one.
4. Try to use another DMX controller.
5. Check if the DMX cables run near or run alongside to high voltage cables that may cause damage or interference to DMX interface circuit.

C. Some fixtures don't respond to the easy controller

1. You may have a break in the DMX cabling.
2. Check the LED for the response of the master/ slave mode signal.

D. No response to the sound

1. Make sure the fixture does not receive DMX signal.
2. Check microphone to see if it is good by tapping the microphone.

E. One of the channels is not working well

1. The stepper motor might be damaged or the cable connected to the PCB is broken.
2. The motor's drive IC on the PCB might be out of condition.

9. Fixture Cleaning

The cleaning of internal must be carried out periodically to optimize light output. Cleaning frequency depends on the environment in which the fixture operates: damp, smoky or particularly dirty surrounding can cause greater accumulation of dirt on the fixture's optics.

- Clean with soft cloth using normal glass cleaning fluid.
- Always dry the parts carefully.
- Clean the external optics at least every 20 days. Clean the internal optics at least every 30/60 days.

EV LIGHT (GUANGZHOU) CO., LTD.

ADD: EV INDUSTRIAL PARK, 68 CHUANGYE ROAD, TAIPING
DEVELOPMENT ZONE, GUANGZHOU

TEL: +86-20-37929678

FAX: +86-20-37929678

WEBSITE: [Http://www.evlightpro.com](http://www.evlightpro.com)