



Jiangsu Zhitai New Energy Technology Co., Ltd.

File Number:

ZT/JS-SM-00001

Version:

A/1

System specification for 48V100Ah Lithium Iron Phosphate Cell

Page Number:

1/ 17

System specification for 48V200Ah Lithium Iron Phosphate Cell

制定：	夏清	客户确认：	
审查：	李亚辉	批准：	
日期：	2020-06-23	日期：	

 Jiangsu Zhitai New Energy Technology Co., Ltd.	File Number:	ZT/JS-SM-00001
	Version:	A/1
System specification for 48V100Ah Lithium Iron Phosphate Cell	Page Number:	2/ 17

Content

1. Product overview	3
2. Product technical specifications	3
3. Working Principle	4
4. Battery management system.....	5
5. Test conditions	8
6. Inspection methods and technical standards.....	9
7. System installation, useage and maintenance	11
8. Product packaging requirements.....	15
9. Product storage and transportation.....	16
10. Precautions for product use.....	16

 Jiangsu Zhitai New Energy Technology Co., Ltd.	File Number:	ZT/JS-SM-00001
	Version:	A/1
System specification for 48V100Ah Lithium Iron Phosphate Cell	Page Number:	3/ 17

1. Product overview

This product is a lithium iron phosphate battery pack (including BMS) designed and manufactured by Jiangsu Zhitai New Energy Technology Co., Ltd. It is composed of 16 strings of battery cells, and the battery cell group adopts intelligent sorting, which is accurate and reliable. BMS uses a professional protection board test system to conduct a comprehensive test before going online to ensure that the BMS can fully and effectively protect the battery pack during use. This product has the characteristics of high energy density, long life, safety and reliability, light weight and wide operating temperature range. It is a green and environmentally friendly product you can trust.

The working principle of the backup lithium iron phosphate battery system after energy storage: the battery outputs 43.2V~53.5V DC voltage, which is inverted into 220V AC power by the inverter, which is used for 220V AC load. The battery has dual protection of BMS and DC MCB. When the battery voltage is too low, the power supply will cut off the battery power supply to protect the battery life.

2. Product technical specifications

Serial number	Project	General parameters
1	Number of series	16S
2	Rated voltage	51.2V
3	End of discharge voltage	43.2V
4	Charging voltage	Recommend 54.4V (54V – 55.2V) flt Recommend 56.4V (56V – 58.4V) eqv
5	Internal resistance (battery pack)	≤100mΩ
6	Self-discharge rate	≤2%/month
7	range of working temperature (≤95%R.H.)	0 ~ 65°C charge 20 ~ 65°C discharge
8	Storage temperature range (≤95%R.H.)	-40 ~ 70°C
9	Positive and negative lead way	Fence terminal 2P*2
12	Protective function	Overcharge, over discharge, short circuit, overload, over temperature, etc.
13	Shipment product charge	50% power when delivery
14	Packing material	Carton



Model	Specification	Nominal Capacity/Ah	Max continuous charge/discharge current/A	Weight /kg	Size/mm				
					Depth	Depth with handle	Width	Width with hanging era	Thickness
ZT-COM-F48V200AH16S	5U480	200	200	76	480	520	442	482	223

3. Working Principle

The battery pack is an energy storage unit composed of lithium iron phosphate batteries. The chemical reactions of the positive and negative electrodes of the charge and discharge are as follows:

	Positive pole	Negative pole
Chemical equation of charging reaction	$\text{LiFePO}_4 \rightarrow \text{Li}_{1-x}\text{FePO}_4 + x\text{Li}^+ + x\text{e}^-$	$x\text{Li}^+ + x\text{e}^- + 6\text{C} \rightarrow \text{Li}_x\text{C}_6$

 Jiangsu Zhitai New Energy Technology Co., Ltd.	File Number:	ZT/JS-SM-00001
	Version:	A/1
System specification for 48V100Ah Lithium Iron Phosphate Cell	Page Number:	5/ 17

Chemical equation of discharging reaction	$\text{Li}_{1-x}\text{FePO}_4 + x\text{Li}^+ + x\text{e}^- \rightarrow \text{LiFePO}_4$	$\text{Li}_x\text{C}_6 \rightarrow x\text{Li}^+ + x\text{e}^- + 6\text{C}$
--------------------------------------------------	-----------------------------------------------------------------------------------------	----------------------------------------------------------------------------

Through the battery management system, the battery pack can perform real-time monitoring of cell voltage, total voltage, current, temperature and other information, and perform battery charge and discharge management while ensuring the health of the monitoring data;

The battery pack and battery management system are installed in the battery shell, the shell is made of metal material, and the upper cover is made of plastic material to ensure the normal transmission of the product's wireless transmission signal.

4. Battery management system

4.1 Description of battery management system

BMS is designed for 16 strings of lithium iron phosphate battery packs. The BMS system has the following functions:

Pre-charge function, over-charge protection function, over-discharge protection function, over-current protection function, short-circuit protection function, equalization function, alarm function, communication function (dual RS485), with 20A current limit function (can be configured as required) ;

4.2 Protection board parameter settings (here, a 200Ah battery is taken as an example, the specific parameters can be adjusted according to actual needs):

S/N	function name	Function setting	Cell voltage alarm	Settings Value	Reference setting range
1	Monomer overvoltage protection	Turn on	Overvoltage protection voltage	3750mV	3000~6000mV



2	Cell undervoltage protection	Turn on	Undervoltage protection voltage	2700mV	100~3200mV
3	Battery overvoltage protection	Turn on	Overvoltage protection voltage	57.6V	40.0V~60.0V
4	Battery undervoltage protection	Turn on	Undervoltage protection voltage	43.2V	30.0V~60.0V
5	Battery temperature prohibits charging	Turn on	Charging over temperature protection	65°C	30°C~90°C
			Charging under temperature protection	0°C	-5~5°C
6	Battery temperature prohibits discharging	Turn on	Discharging over temperature protection	65°C	30°C~90°C
			Discharging under temperature protection	-10°C	-5~5°C
7	Overcurrent protection	Turn on	Charging overcurrent protection	205A	0A~210A
8	Charging current limit function	Turn on	Charging current limit	20A	5A~20A
9	Factory capacity setting	Factory setting of rated capacity		200Ah	1Ah~200A
10	Battery failure alarm	Turn on	Battery failure voltage difference	2000mA	Recovery of cell voltage difference ~2000mV

4.3 Communication description

BMS has the RS485 communication function that supports battery pack cascade, and the default



baud rate is 9600bps. RS485 cascade communication interface adopts 8P8C straight PCB welding telephone socket (round pin); RS485 has the communication function that supports cascade battery pack upload, and the communication address bit starts from "1".

4.3.1 The definitions of RS485 communication interfaces are as follows:

Pin	Definition
1,8	RS485-B
2,7	RS485-A
3,6	Ground
4,5	NC

4.3.2 Parallel communication

When multiple battery modules are connected in parallel, the RS485 interface is used as the parallel communication interface, and the communication address bit starts from "1"; when the two RS485 interfaces are in parallel, they can be connected with one-to-one corresponding network cables.

The connection of a single RS485 interface is shown in the figure below:

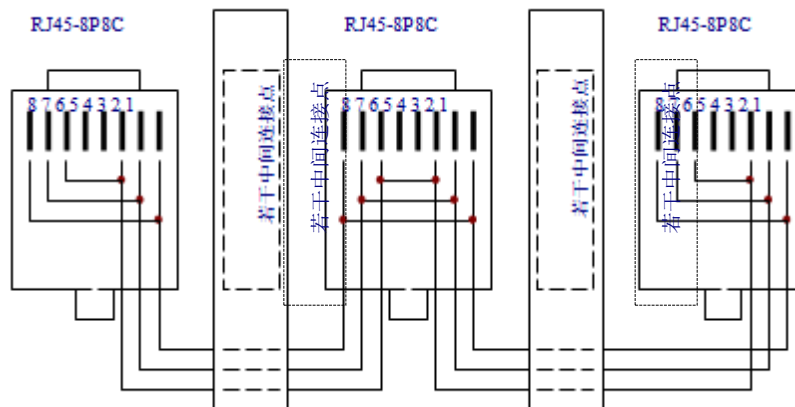

4.3.3 DIP switch to select address

When the battery pack is used in parallel, different PACKs can be distinguished by the hardware address, and the hardware address of each PACK in the entire battery stack is unique. The hardware address can be set in sequence through the dial switch on the board. For the definition of the switch, refer to the following table.



Address	DIP switch position				Description
	#1	#2	#3	#4	
0	OFF	OFF	OFF	OFF	Set to



					Pack0
1	ON	OFF	OFF	OFF	Set to Pack1
2	OFF	ON	OFF	OFF	Set to Pack2
3	ON	ON	OFF	OFF	Set to Pack3
4	OFF	OFF	ON	OFF	Set to Pack4
5	ON	OFF	ON	OFF	Set to Pack5
6	OFF	ON	ON	OFF	Set to Pack6
7	ON	ON	ON	OFF	Set to Pack7
8	OFF	OFF	OFF	ON	Set to Pack8
9	ON	OFF	OFF	ON	Set to Pack9
10	OFF	ON	OFF	ON	Set to Pack10
11	ON	ON	OFF	ON	Set to Pack11
12	OFF	OFF	ON	ON	Set to Pack12
13	ON	OFF	ON	ON	Set to Pack13
14	OFF	ON	ON	ON	Set to Pack14
15	ON	ON	ON	ON	Set to Pack15

5. Test conditions

5.1 Environmental conditions

Unless otherwise specified, the tests specified in this standard shall be carried out under the following normal atmospheric conditions: Ambient temperature: 23°C ~ 27°C

Relative humidity: 45% ~ 85%

Air pressure: atmospheric pressure 86kPa ~ 106kPa

5.2 Measuring instruments and equipment

 Jiangsu Zhitai New Energy Technology Co., Ltd.	File Number:	ZT/JS-SM-00001
	Version:	A/1
System specification for 48V100Ah Lithium Iron Phosphate Cell	Page Number:	9/ 17

All instruments and equipment (including test equipment and instruments for monitoring or monitoring test parameters) shall be verified or qualified in accordance with the relevant national metrological verification regulations or relevant standards and within the validity period. All test instruments and equipment should have sufficient accuracy and stability, and their accuracy should be one order of magnitude higher than the accuracy of the measured index or the error should be less than one-third of the allowable error of the measured parameter.

The test equipment, instruments and materials provided by the ordering party shall be specified in the contract and stated in the test program.

- a) Voltmeter: accuracy should not be less than 0.5, and its internal resistance should be at least 10kΩ/V;
- b) Ammeter: accuracy should not be less than 0.5;
- c) Thermometer: with appropriate measuring range, the division value is not more than 1°C, and the calibration accuracy is not less than 0.5°C;
- d) Timer: divide by hour, minute and second, with an accuracy of ±1%;
- e) Measuring tool for measuring size: the graduation value is not more than 1mm;
- f) Weighing instrument for weighing: the accuracy is above ±0.05%.

5.3 Charge and discharge system

Charge the fully discharged battery pack with an adjustable constant current and constant voltage power supply (set the voltage limit to 56.4V, and set the current limit to 30A) until the battery pack charging indicator indicates full charge (4 LEDs are always on). At this time, the battery pack is fully charged.

6. Inspection methods and technical standards

6.1 General characteristics

project	testing method	Technical requirement
Appearance	Visually inspect the appearance quality of the tested battery pack	The appearance of the product should be clean, and there should be no cracks, cracks, dents, trachoma, deformation and other forms of mechanical damage, and there should be no rust on the output end.
Polarity symbol	Test the positive and negative poles of the battery pack with a multimeter	The polarity of the battery pack should be consistent with the polarity symbol on the mark.
Logo and code	Visually inspect the logo and code of the battery pack being tested.	The logo and code on the battery pack are clear and correct
Open circuit voltage	Measure the open circuit voltage at both ends of the battery pack with a voltmeter that meets the requirements of Clause 5.2	The open circuit voltage of the battery pack is 51.2V ~ 53V



Discharge capacity at room temperature	Charge the battery pack in accordance with Article 5.3, leave it for 1 hour, place the battery pack under the environmental conditions specified in 5.1, and discharge with a constant current of (0.2C) to the discharge termination voltage or battery pack protection.	Discharge capacity ≥ minimum nominal capacity
----------------------------------------	---------------------------------------------------------------------------------------------------------------------------------------------------------------------------------------------------------------------------------------------------------------------------	-----------------------------------------------

6.2 Environmental adaptability

project	testing method	Technical requirement
Low temperature capacity	Charge the battery pack according to Article 5.3, then place the battery pack in a low temperature box at $-10^{\circ}\text{C} \pm 2^{\circ}\text{C}$ for 8 hours, and then discharge with (0.1C) current to the end voltage or battery pack protection.	The battery capacity is $\geq 70\%$ of the rated capacity.
High temperature capacity	Charge the battery pack in accordance with the provisions of Article 5.3, then place the battery pack in a low temperature box at $55^{\circ}\text{C} \pm 2^{\circ}\text{C}$ for 8 hours, and then discharge with (0.1C) current to the termination voltage or battery pack protection.	Battery pack discharge capacity $\geq 99\%$ rated capacity
Charge retention rate and recovery capacity	The battery pack is charged according to the provisions of 5.3, and then stored at room temperature for 28d, the battery pack is discharged with (0.2C) current to the end voltage or battery pack protection. Then follow the provisions of 5.3 to fully charge the battery and let it stand for 1h, and then discharge it with (0.2C) current to the end voltage or battery pack protection.	After 28 days, the discharge capacity of the battery pack is $\geq 96\%$ of the rated capacity;
Cycle life	After the battery pack is fully charged according to the provisions of 5.3, put it aside for at least 10 minutes, discharge the battery pack with a current of (0.5C), discharge to the termination voltage or battery pack protection, and complete a charge-discharge cycle. Repeat the charge and discharge cycle.	The 1000th discharge capacity of the battery pack $\geq 80\%$ of the rated capacity

6.3 Safety performance

Test items	testing method	Technical requirement
Short circuit	After charging the standard battery pack, place it in an explosion-proof box, and short-circuit the positive and negative electrodes outside the battery pack with wires with an internal resistance of less than 100mΩ. During the test, record the surface temperature of the battery. The short-circuit lasts for 10 minutes. The cell undergoes short-circuit safety assessment test.	No fire or explosion (without protective circuit and shell test)



Overcharge	After charging the battery pack standardly, use a constant current and constant voltage source to charge a single cell of the battery pack (0.2C), charge it to 5V and switch to constant voltage charging until the cut-off current reaches 0A or the surface temperature is lower than the ambient temperature When the temperature is below +10°C, the test ends.	No fire or explosion (without protective circuit and shell test)
Overdischarge	After standard charging of the battery pack, use a load meter to discharge the battery pack continuously at 0.5C until the voltage of a single cell reaches 0~0.5V, the test is ended.	No fire or explosion (without protective circuit and shell test)
vibration	Fix the fully charged battery pack as specified in 5.3 on the shaker, and cyclically sweep the frequency from 10Hz to 55Hz for 90min-100min, the sweep rate is 1oct/min, and the displacement amplitude is 0.76mm (single amplitude).	The battery pack should not leak, fire, or explode, and work normally.
Free fall	The battery fell freely from a height of 1m onto a 20cm thick hardwood board.	The battery pack should not leak, fire or explode.

7. System installation, useage and maintenance

7.1 System installation

7.1.1 Embedded installation in 19" standard cabinet

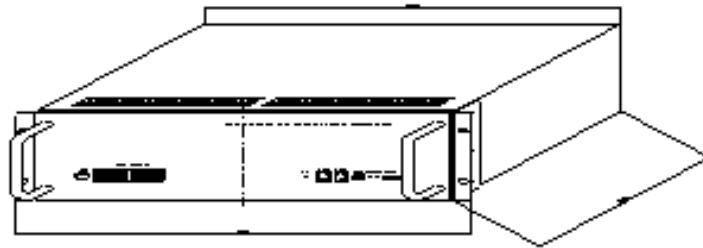

1) It is recommended to install the battery in a 19" standard cabinet or wall-mounted installation. Use 4 M6 bolts to fix the system on the rack at the mounting ears on both sides of the cabinet;

2) Connect the positive and negative poles of the output terminals on the iron-lithium battery system chassis to the positive and negative poles of the switching power supply or equipment with the red and black cords over 10mm², and pay attention to the positive and negative signs.

3) When multiple battery modules are connected in parallel to form a large-capacity battery pack, a unified and standard bus parallel connection is required. The positive and negative poles of each battery module should be connected to the bus bar through a cable, and then the bus bar should be connected to the battery terminal of the switching power supply.



7.1.2 Cabinet installation

Cabinet type installation generally consists of 19-inch standard cabinets, battery packs, bus bars, connecting wires and other components. The height of the 19-inch cabinet can be configured according to the number of batteries. The installation sequence is as follows:

- 1) Connect the + and - poles of the battery system to the parallel busbars above the cabinet with red and black cords over 10mm². Connect the red wire to "+" and the black wire to "-";
- 2) Place each battery module on the cabinet tray. Use M6 combination screws to fix the mounting ears of each battery module on the bracket in the cabinet;
- 3) Lead out the total positive and total negative two wires from the bus bar of the cabinet and connect them to the positive and negative ends of the switching power supply or equipment

7.1.3 Wall-mounted installation

As shown in the figure, when the system is installed, use 4 M8 expansion screws to fix its two hanging ears on the wall, with an interval of 445 mm. Use 2 M8 expansion screws to fix the tripod under the battery to support the battery.

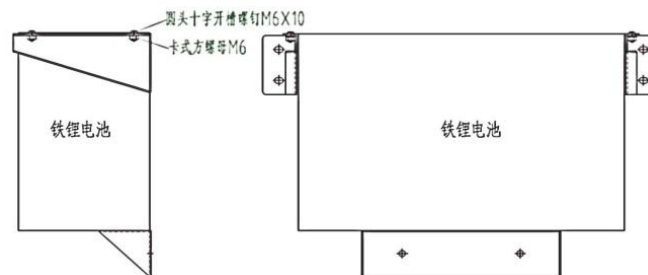

7.2 Power on the system

After the system is installed, it is generally in a standby state. When needed, the system can be put into normal operation through a simple power-on operation

7.2.1 System activation

During storage, transportation, or after 24 hours without external power supply and no load, the battery system has been in a dormant state. After the allowable charging voltage is added, the battery system is activated and enters a normal operating state, and can be charged, discharged, or enter a standby state. It should be noted that when the battery system is in a sleep state, the charging power supply used with the battery system must cancel its anti-reverse protection function, so that the 48V voltage can activate the battery system after the AC is restored.

7.2.2 System Standby

After the system is activated, if the external power supply and load are removed, the battery system will actively enter the standby state. In this state, the power consumption is extremely low, and the RUN light on the panel flashes to indicate that the battery system is in standby state. After 24 hours, the battery system will automatically go to sleep. In this state, the power loss will be lower, and the indicator light on the panel is completely off, indicating that the battery system is in a sleep state.

7.2.3 Sleep state and activation conditions

 Jiangsu Zhitai New Energy Technology Co., Ltd.	File Number:	ZT/JS-SM-00001
	Version:	A/1
System specification for 48V100Ah Lithium Iron Phosphate Cell	Page Number:	13/ 17

The BMS has manual and automatic sleep functions. When the external voltage is offline and there is no discharge, the BMS automatically enters the sleep state after the duration reaches 0.25h. The BMS can also enter the dormant state through software instructions or manually; when the BMS enters the over-discharge protection state and keeps it for a duration, the BMS enters the dormant state.

When the battery pack is in the dormant state, the battery pack is always in the dormant state without external voltage activation or manual activation, and discharge is prohibited.

When the lithium battery pack changes from the offline state (that is, the state where the output terminal of the battery pack is positive and negative, and the communication interface is disconnected from the outside) to the online state (that is, the state where the output terminal of the battery pack is positive and negative, and the communication interface is connected to the outside world), the BMS should be able to timely Respond to and judge the external conditions, and automatically activate, and adjust the working status according to the power, load and battery pack status.

Note: When the communication activation function is turned on, the BMS cannot enter sleep mode under the state of using RS485 or RS232 interface to communicate with the outside world. After entering the dormant state, the BMS can be activated by connecting the RS485 or RS232 interface to communicate with the outside world.

7.3 Alarm description and handling

When the system fails, an alarm signal will be given. When an alarm occurs, the red alarm light on the monitoring unit is on, and an alarm message is sent to the remote monitoring center. When an alarm occurs in the system, the remote monitoring center receives the alarm information, and the maintenance personnel should immediately check the corresponding equipment according to the alarm information prompted by the monitoring unit, determine the type and location of the fault, and take corresponding countermeasures.

7.3.1 Alarms that can affect system output and their countermeasures

If there are any faults in the system that affect the output such as overvoltage of single battery, overcurrent of charging, undervoltage protection, temperature protection, etc., please deal with it according to Table 8-1.

status	Alarm parameters	Alarm indication	Treatment measures
charging	Cell overpressure	ALM always on	Stop charging and find the cause of the failure
	Charging overcurrent	ALM always on	Stop charging and find the cause of the failure
	Charging temperature protection	ALM always on	Stop charging
Discharging	Discharge overcurrent	ALM always on	Stop discharging and find the cause of failure



	protection		
	Discharge temperature protection	ALM always on	Stop discharge
	Total voltage undervoltage protection	All LEDs Go out	Recharge
	Cell voltage undervoltage protection	All LEDs Go out	Recharge

7.3.1 Alarms that can not affect system output and their countermeasures

If there is a low total voltage alarm or low cell voltage, the battery system also generates a corresponding alarm signal. The maintenance personnel should check the equipment according to the prompt information, determine the fault type and location, and take corresponding countermeasures to ensure that the system is in the best working condition and prevent the fault from getting worse, so as not to affect the system output. The phenomenon and countermeasures are shown in Table 8-2.

Alarm parameters	FET action	Alarm indication	Treatment measures
Total voltage low voltage alarm	no	ALM flashes	Stop discharging
Cell voltage low voltage alarm	no	ALM flashes	Stop discharging

7.4 Communication failure

The status of the protection and the status of the system can be read on the host computer software to help analyze the specific cause of the failure.

i. When RS232 communication failure occurs, follow the steps below to troubleshoot:

a. Check the communication line;

b. Reset MasterPack;

c. For cascaded systems, you can switch the settings of MasterPack and SlavePack for diagnosis.

ii. When RS485 communication failure occurs, follow the steps below to troubleshoot:

a. Check the communication line;

b. Reset the SlavePack;

c. Change the address setting of SlavePack to diagnose

o

7.5 Protection failure

7.5.1 Overvoltage protection

When using the standard charging voltage, the internal cell overvoltage will not generally occur,

 Jiangsu Zhitai New Energy Technology Co., Ltd.	File Number:	ZT/JS-SM-00001
	Version:	A/1
System specification for 48V100Ah Lithium Iron Phosphate Cell	Page Number:	15/ 17

unless there is a large imbalance between the cells. If the voltage is very unbalanced, when the cell is overvoltage and the total voltage is still relatively low, protection will occur, and the cell voltage needs to be checked.

7.5.2 Current protection

When the current of the system is relatively small and current protection occurs, you need to check the status indicator to check whether the connection line is normal.

7.5.3 Other faults

If a protection alarm occurs and cannot be charged or discharged, you need to check the specific voltage, temperature and other parameters and system status indicators to determine the cause of the failure.

7.6 Measures for handling special circumstances

7.6.1 Power failure

AC power failure is the most common situation in system operation. When the power failure is not long, the DC power supply is provided by the iron-lithium battery pack in the system. If the cause of the power failure is unknown or the time is too long, pay attention to the power supply time of the system.

7.6.2 Catastrophe

Catastrophic accidents include communication equipment failures caused by lightning, flooding, earthquakes, fires and other disasters.

7.6.3 Normalization of operation and maintenance of lithium iron phosphate battery packs

After the installation and commissioning of the system project is completed, if the mains power is not connected or the system is not turned on, be sure to disconnect the MCB of the lithium iron phosphate battery pack. The mains should be connected as soon as possible, and the battery should be recharged to avoid the battery pack being in a state of power loss for a long time, and to avoid causing the battery to fail.

7.6.4 Use stable and reliable switching power supply

Use a switching power supply that adapts to a wide range of mains voltage fluctuations, or use a switching power supply that meets both the 110V and 220V dual-standard mains requirements. To avoid the safety risk of the switching power supply's output DC voltage being unstable under the harsh conditions of the mains. Find faults in time, repair or replace them in time, and use switching power supplies with stable and reliable quality.

8. Product packaging requirements

8.1 The appearance of the chassis is good, and there should be no defects such as scratches, paint peeling, deformation, or damage;

8.2 Please refer to the packaging process document for the product label

8.3 Before packaging, the upper computer sets the forced sleep state;

8.4 After the battery has passed the appearance inspection, the PE bag shall be set:

8.5 The material and hardness of the outer carton ensure the safety of turnover and transportation;

 Jiangsu Zhitai New Energy Technology Co., Ltd.	File Number:	ZT/JS-SM-00001
	Version:	A/1
System specification for 48V100Ah Lithium Iron Phosphate Cell	Page Number:	16/ 17

8.6 There should be shaped buffer packaging materials inside; packaging material considerations: placement of terminal posts, bagged screws, hanging ears, etc.;

8.7 Bagging of accessories: battery manual, certificate, combination screws; quantity and configuration are as follows:

S/N	Accessory name	Remarks
1	Battery manual *1 copy	This text
2	Qualification certificate*1	See the real thing
3	Combination screws × 4	Combination screw M6*12mm with washer and film, countersunk Phillips flat foot machine screw

9. Product storage and transportation

9.1 Product storage

When the product is stored for a long time and not in use, please place it in a dry and ventilated place, avoid inflammable and explosive materials; charge and maintain the battery pack regularly every three months to ensure that the battery is in the best performance state.

9.2 Product transportation

The battery pack should be packaged outside before being transported. During transportation, it should be protected from violent shaking, impact or squeezing, and from sun and rain.

10. Precautions for product use

10.1 10.1 Do not put the battery in water or get it wet.

10.2 10.2 It is forbidden to charge and use the battery outside the temperature range specified by us; do not store, charge and use this product near fire or heat sources.

10.3 10.3 When the battery pack emits a peculiar smell or leaks, stop using it or stop charging immediately, and move it to an open and ventilated place, away from the fire source, and contact us in time.

10.4 10.4 When connecting to a load, do not connect the positive and negative poles reversely.

10.5 10.5 Do not short-circuit the positive and negative poles of the battery pack with metal conductors.

10.6 10.6 Do not throw the battery pack into fire or heat it.

10.7 10.7 It is strictly forbidden to conduct artificial dissection of the battery pack. It is strictly forbidden to pierce the battery pack with nails or sharp objects. It is strictly forbidden to hit the battery pack with a hammer or other external force. It is strictly forbidden to step on and drop the battery pack.

10.8 10.8 It is strictly forbidden to put the battery pack in a microwave oven or pressure vessel.

10.9 10.9 If any abnormal phenomenon occurs during charging or use, please stop charging and use immediately.

10.10 10.10 The best use temperature of the product is $25\pm 5^{\circ}\text{C}$. If the product is not within this temperature range during use, the discharge capacity will be reduced.

10.11 10.11 If there is a malfunction or abnormality during use, please contact us and do not disassemble

 Jiangsu Zhitai New Energy Technology Co., Ltd.	File Number:	ZT/JS-SM-00001
	Version:	A/1
System specification for 48V100Ah Lithium Iron Phosphate Cell	Page Number:	17/ 17

the battery pack privately.