

NANNING TAGRM CO.,LTD

Tel : 86-771-5384871 Fax : 86-771-5384371

Add:NO.399, Wuxiang Avenue, Liangqing District, Nanning, Guangxi,China

E-mail:sale@tagrm.com

Mobile:86-13822531567

M6500 COMPOST TURNER

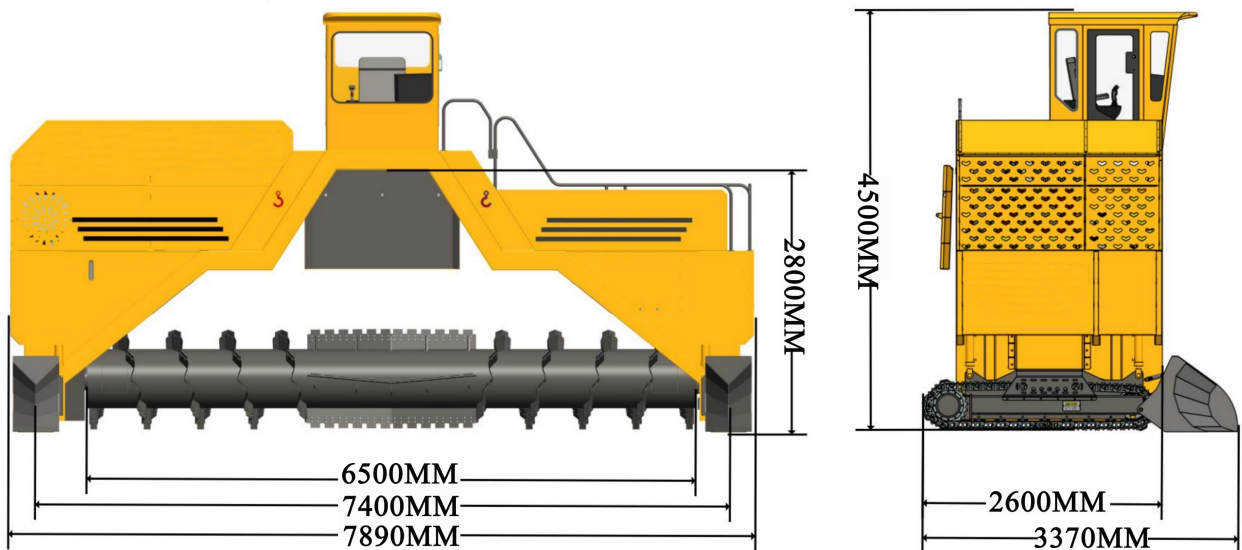

NANNING TAGRM CO.,LTD

Tel : 86-771-5384871 Fax : 86-771-5384371

Add:NO.399, Wuxiang Avenue, Liangqing District, Nanning, Guangxi,China

E-mail:sale@tagrm.com

Mobile:86-13822531567

Specification

Model	M6500		Ground clearance	100mm	H2
Rate Power	288KW(MAX317KW)	WP12D317E201	Ground pressure	0.82Kg/cm ²	
Rate speed	1800 r/min		Working width	6500~7400mm	Max.
Fuel consumption	≤210g/KW·h		Working height	2800mm	Max.
Battery	DC24V	2×12V	Pile shape	Triangle	42°
fuel capacity	320L		Forward speed	L: 0-8m/min H: 0-24m/min	
Crawler tread	7400mm	W2	Rear speed	L: 0-8m/min H:0-24m/min	
Crawler size	2450×400mm	Steel with shoe	Feed port width	7400	mm
Oversize	3370×7890×4500mm	L1×W3×H1	Turning radius	4000	mm
Weight	13000kg	Without fuel	Drive mode	Hydraulic control	
Diameter of roller	1080mm	With knife	Working capacity	4350m ³ /h	Max.

SPECIAL ROLLER FOR GARBAGE COMPOST

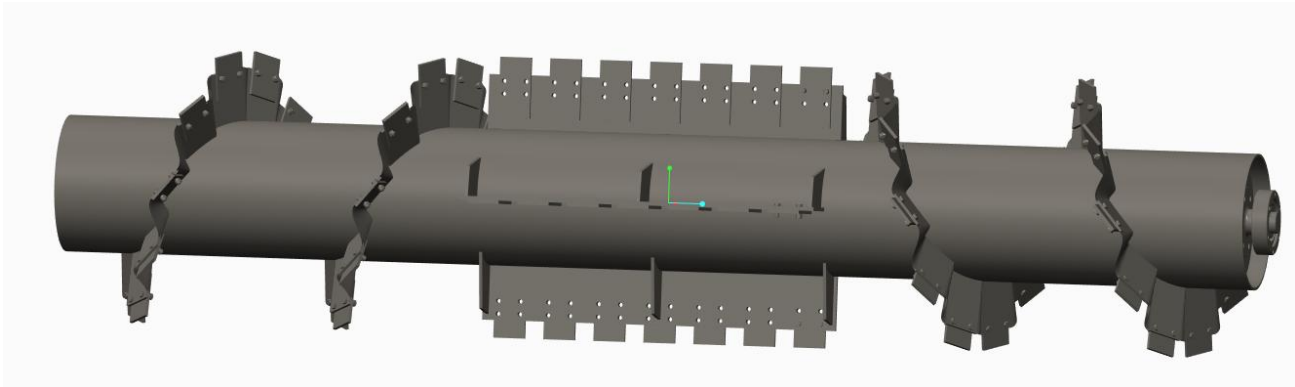

Crawler type: steel with rubber shoe



Payment terms: T/T 30% advanced, 70% before loading ship

Delivery lead time: 30days

Load: 1set/ 40 HQ Container

Packing: Nude

Note: Cost of installation and technical support/training extra.

Products' picture and data just for reference, it will some different after developed.

NANNING TAGRM CO.,LTD

Tel : 86-771-5384871 Fax : 86-771-5384371

Add:NO.399, Wuxiang Avenue, Liangqing District, Nanning, Guangxi,China

E-mail:sale@tagrm.com

Mobile:86-13822531567

ENGINE(WEICHAI)

Brand	WEICHAI	Peak Torque/Speed	1780/1200-1500N.m/rpm
Model	WP12D317E201	Cold Style	Water-cooled
Displacement	11.6L	Emission standard	China stage IIIA
Cylinder diameter	126mm	Cylinder No.	6
Piston stroke	155mm	Electronic control system	ECM
Rate speed	1800r/min	Fuel	Diesel
Roted Power	288kW	Weight	1050KG
Fuel consumption	210g/Kw.h	Working temp	-30~50°C

