

NANNING TAGRM CO.,LTD

Tel : 86-771-5384871 Fax : 86-771-5384371

Add:NO.399, Wuxiang Avenue, Liangqing District, Nanning, Guangxi,China

E-mail:sale@tagrm.com

Mobile:86-13822531567

M4300 COMPOST TURNER

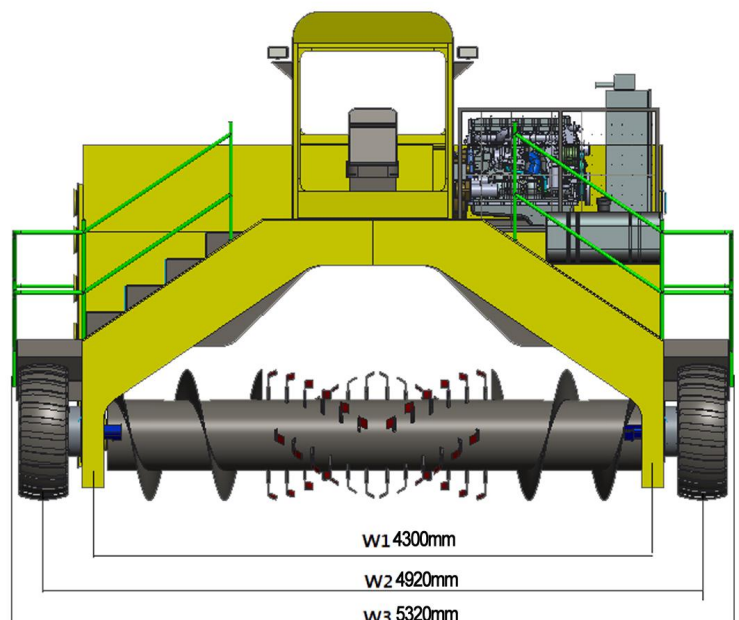
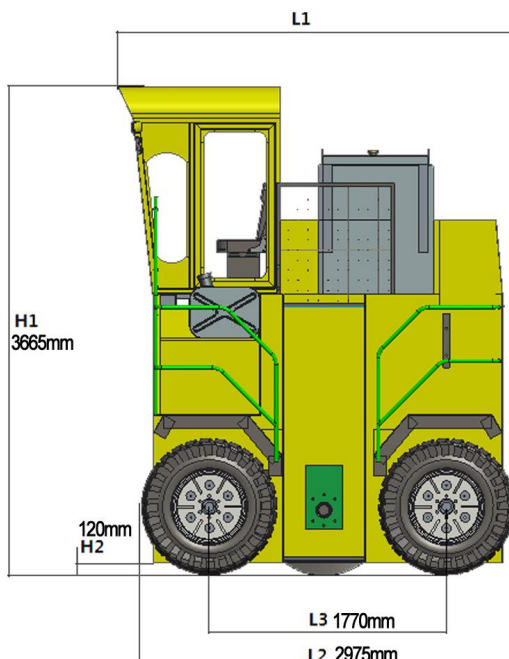

NANNING TAGRM CO.,LTD

Tel : 86-771-5384871 Fax : 86-771-5384371

Add:NO.399, Wuxiang Avenue, Liangqing District, Nanning, Guangxi,China

E-mail:sale@tagrm.com

Mobile:86-13822531567

Specification

Model	M4300		Ground clearance	120mm	H2
Rate Power	182KW (247PS)		Ground pressure	0.75Kg/cm ²	
Rate speed	2200 r/min		Working width	4300mm	Max.
Fuel consumption	≤231g/KW·h		Working height	2000mm	Max.
Battery	24V	2×12V	Pile shape	Triangle	42°
fuel capacity	200L		Forward speed	L: 0-8m/min H: 0-21m/min	
Wheel tread	4920mm	W2	Rear speed	L: 0-8m/min H:0-21m/min	
Wheel base	1770mm	L3	Feed port width	4300	W1
Oversize	5320×2795×3650mm	W3×L1×H1	Turning radius	2750mm	mini
Weight	10000kg	Without fuel	Drive mode	Hydraulic control	
Diameter of roller	979mm	With knife	Working capacity	2050m ³ /h	

Payment terms: T/T 30% advanced, 70% before loading ship

Delivery lead time: 30days

Load: 1set/ 40 HQ Container

Packing: Nude

Note: Cost of installation and technical support/training extra.

Products' picture and data just for reference, it will some different after developed