

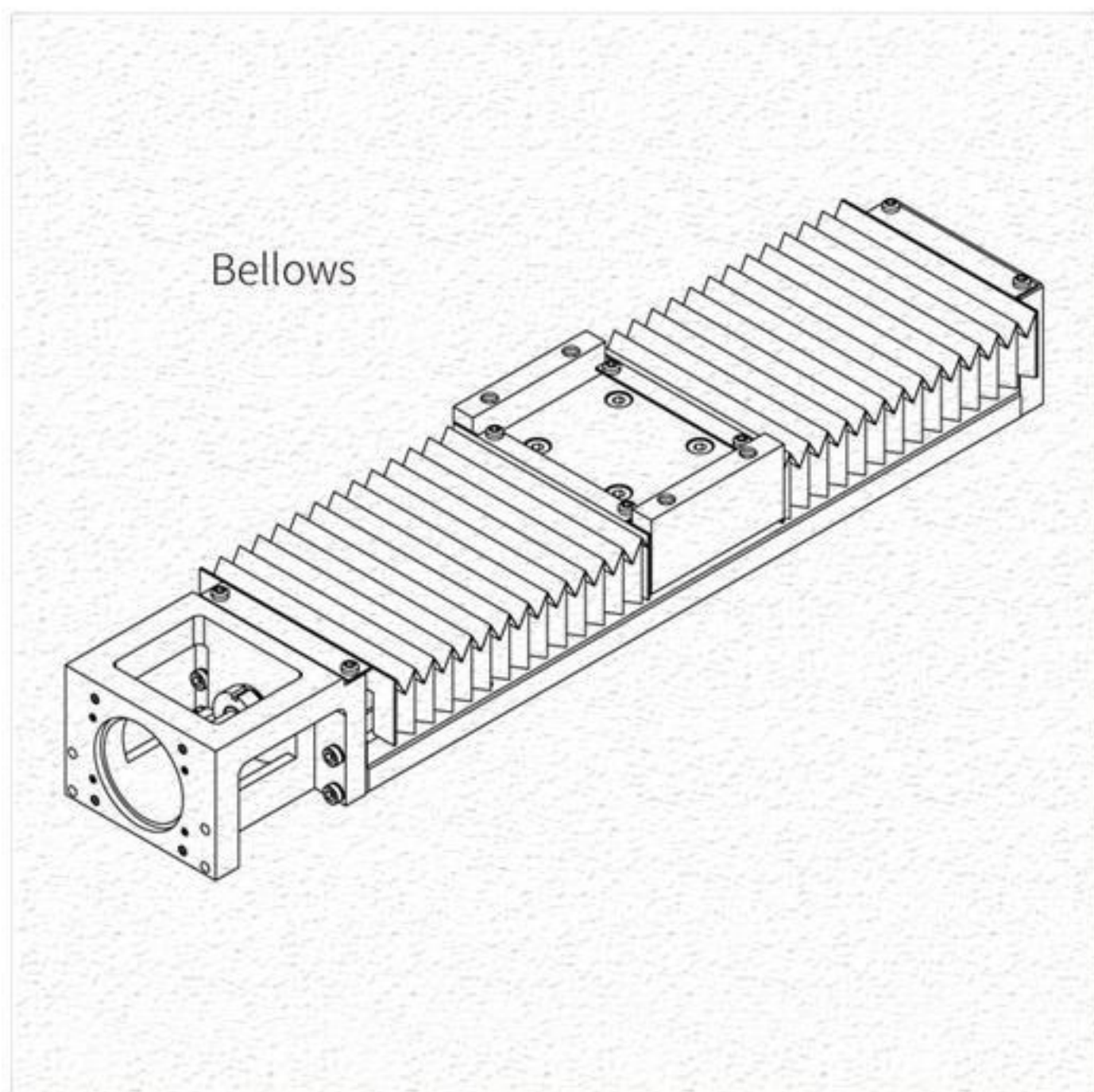

Auto Linear Motion

## Linear Module

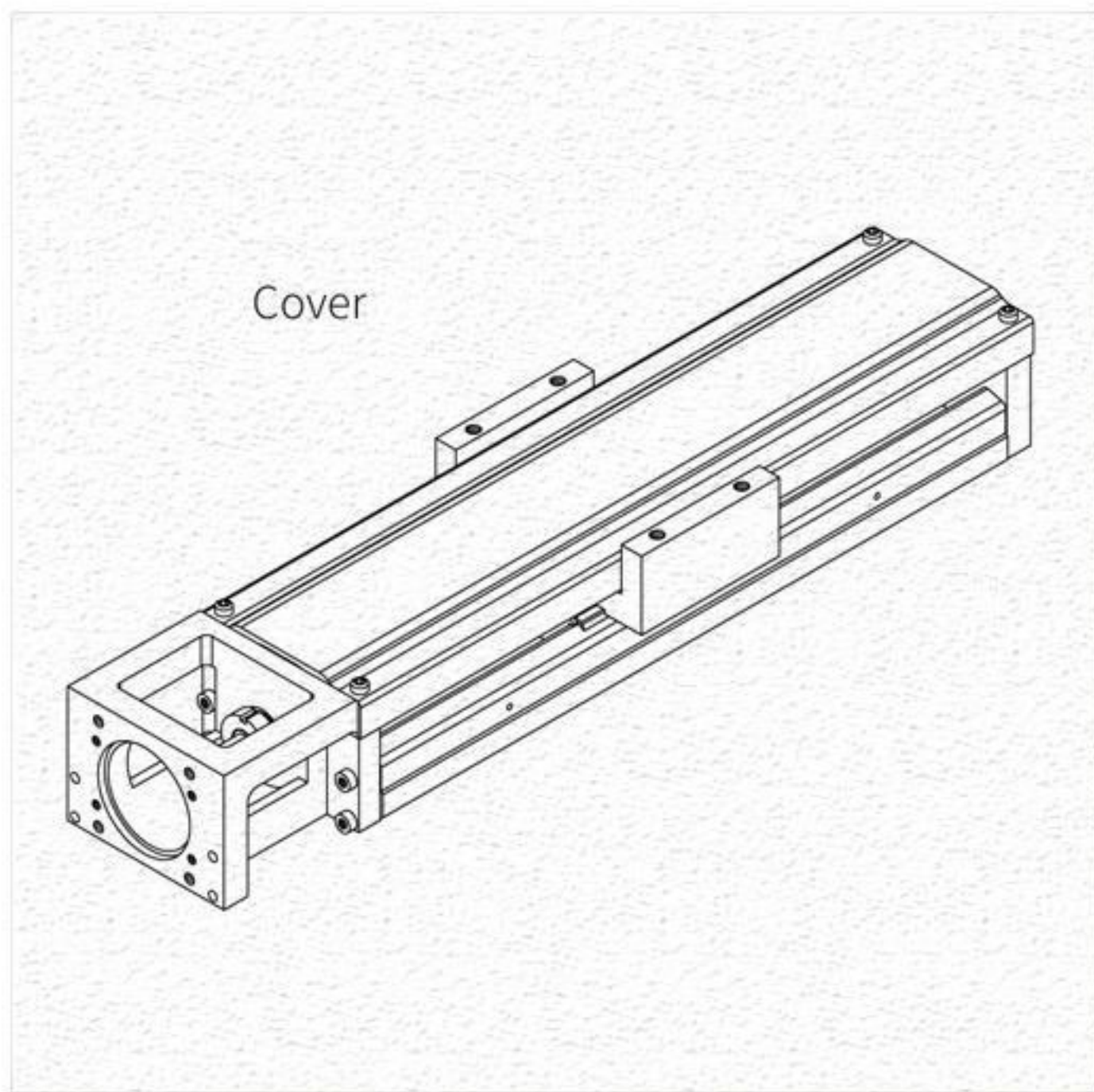
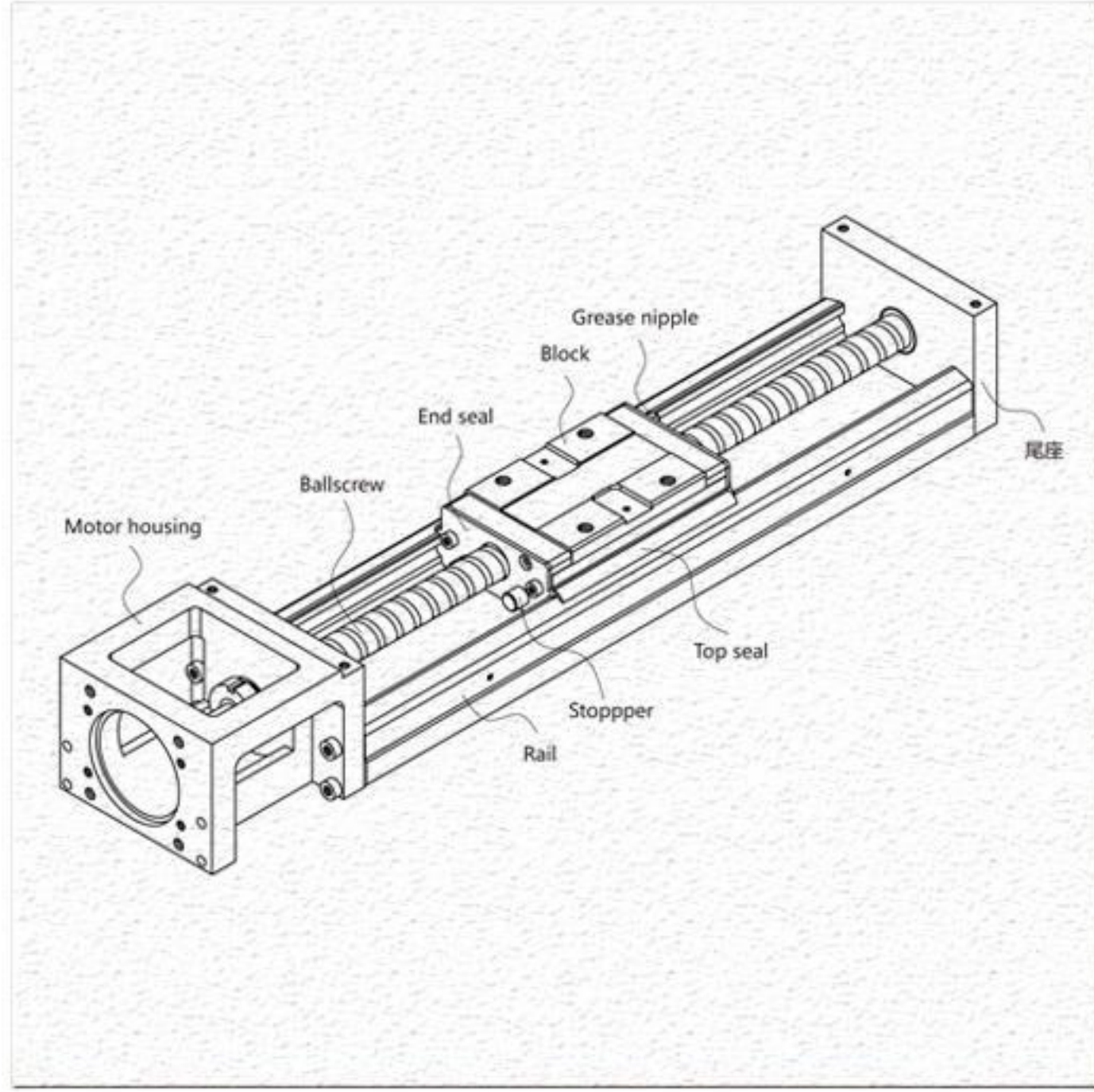

# ***ALM Intelligent Technology (Suzhou) Co., Limited***

Add: No 1998 Jinfeng south road, Wuzhong district, Suzhou city, China

E-mail: [sales@autolinearmotion.com](mailto:sales@autolinearmotion.com)

Tel: +8618962406535

Web: [www.autolinearmotion.com](http://www.autolinearmotion.com)



## General Overview

---

### Warning

---

Single Axis Robots have both electrical and mechanical components, for safety, please read and follow all of the related precautions before selection and use. ALM is not held responsible for any malfunctions, damages, or accidents caused by the misuse of the product.

### Personal Safety

---

- Single Axis Robots are designed for industrial purposes only.
- During operation, the user should stay clear of the Single Axis Robots mechanical range of motion to avoid possible injury.
- When the motor power is ON, people with pacemakers should keep away at least one meter to avoid any disturbance.
- To prevent fires, Single Axis Robots should not be placed near the ignition of flammable gases.

### Storage and Installation

---

- Avoid any possible collisions or dropping of the product.
- When storing, it is recommended that the product be well packed and laid down flat. Do not expose the product to hot, cold or humid conditions.
- Do not disassemble or modify the products to avoid possible malfunctions or accidents.
- During installation, ensure the product is fixed correctly to avoid any loosening caused by vibrations.
- Take care when selecting the correct coupling and motor hardware for installation and be aware of the alignment to the centerline of the shaft when tightening the screws. Do not force the install.

### Operation

---

- The operation conditions need to be within the rated values as shown in the technical information.
- Avoid dust, debris and any foreign objects from entering the ball return system.
- Operational temperature should be under 80 °C. In high temperature environments above 80°C, please contact ALM sales.
- Confirm first with ALM sales if the product can be used in a special environment, such as: vacuum, vibration, clean room, corrosive chemicals, organic solvents, extreme high or low temperatures, humidity, liquid splashes, oil drops or mist, high salt, heavy load, vertical or cantilever installations.
- For vertical installations, when loaded, there is a possibility that the slider may fall. We recommend to adding proper braking and ensure functionality before operation.

### Maintenance

---

- Lubricate the product before the initial use. Note the type of grease used and avoid mixing different types together.
- For normal operating conditions, it is recommended to check the operation every 100km, clean and supply grease onto the rail and shaft.



## General Overview

ALM KK Single Axis Robot is driven by a ballscrew while a guideway slides on an optimized U-rail to achieve higher accuracy and greater stiffness.

### Features

- An integrated system
- Easy installation and maintenance
- Compact and lightweight
- High accuracy
- High stiffness
- Complete line of accessories

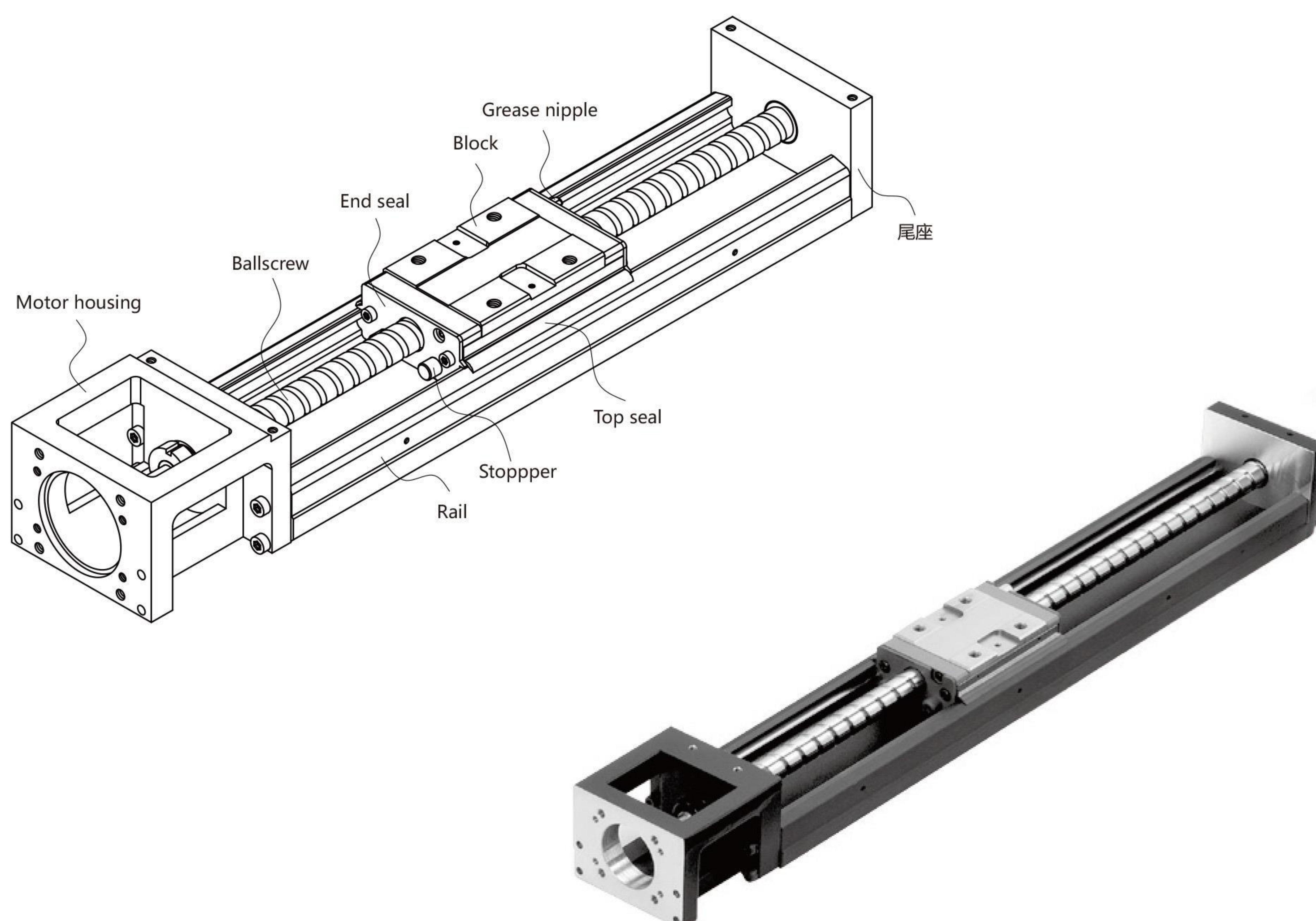
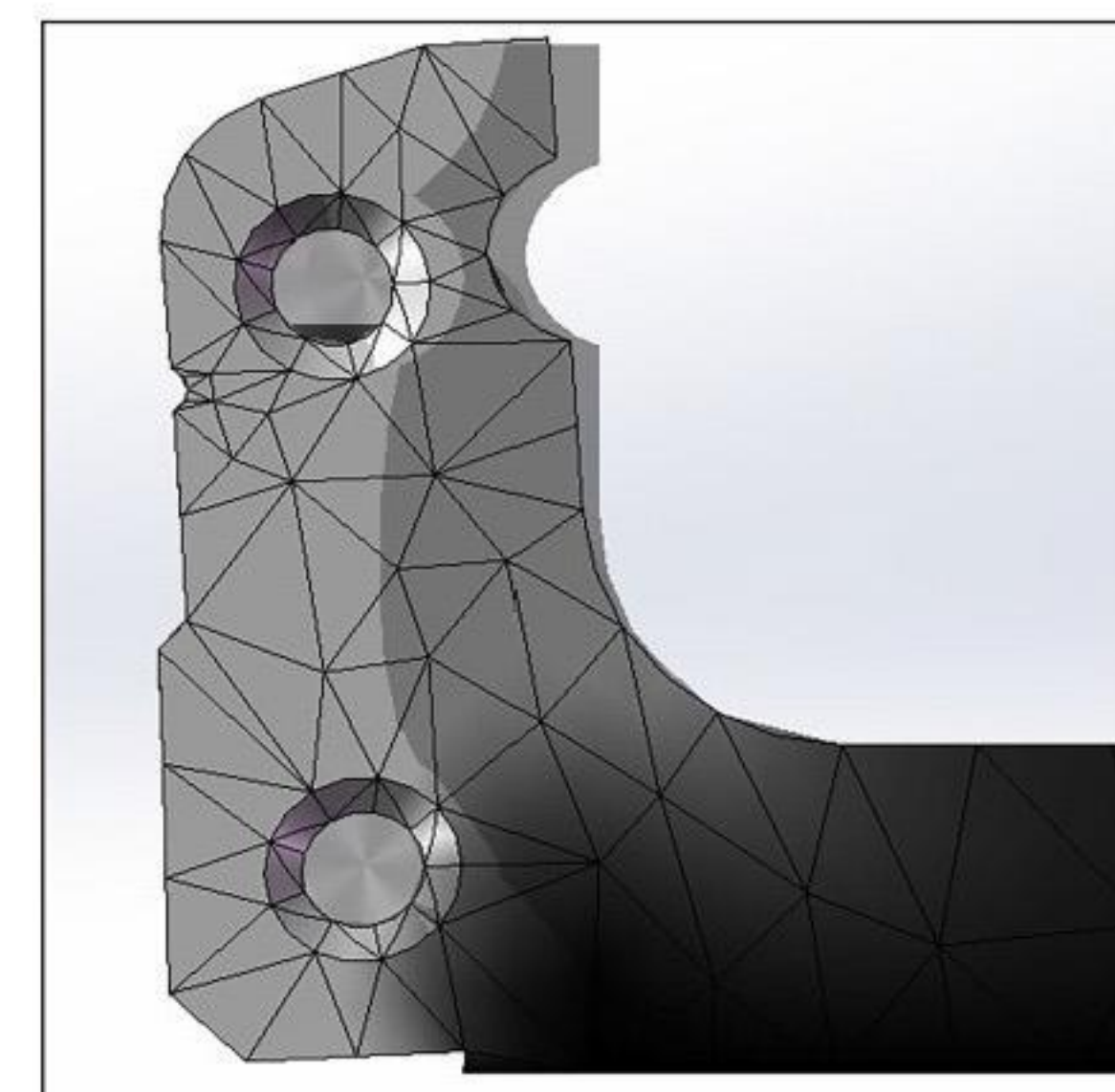
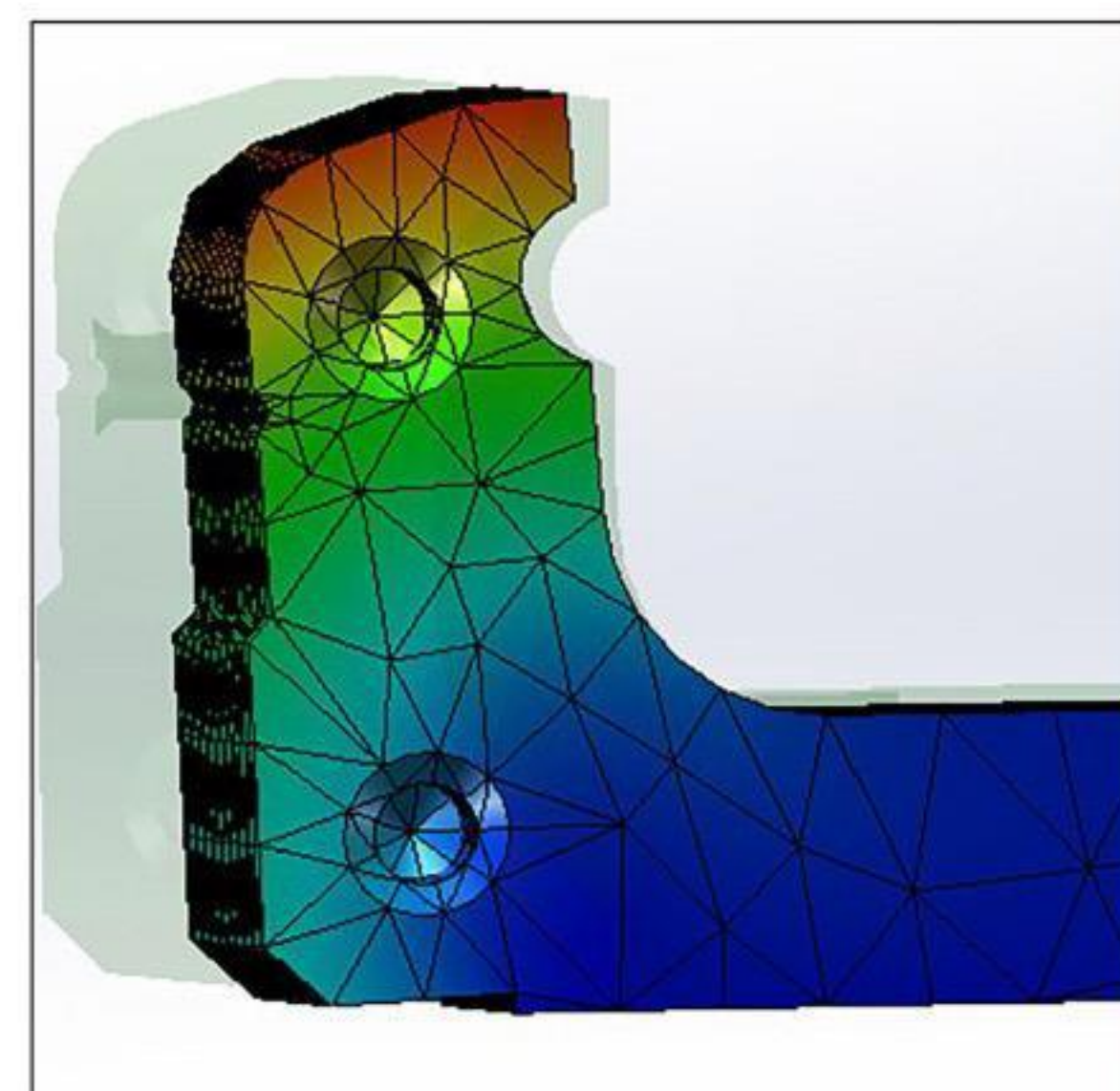



# KK

## Modulization

The KK Single Axis Robot integrating a baUscrew and guideway forms a modularized product. The modularized design can help customers save time, cost and system inspection. Therefore, installation efficiency and a space-saving design are also promoted.

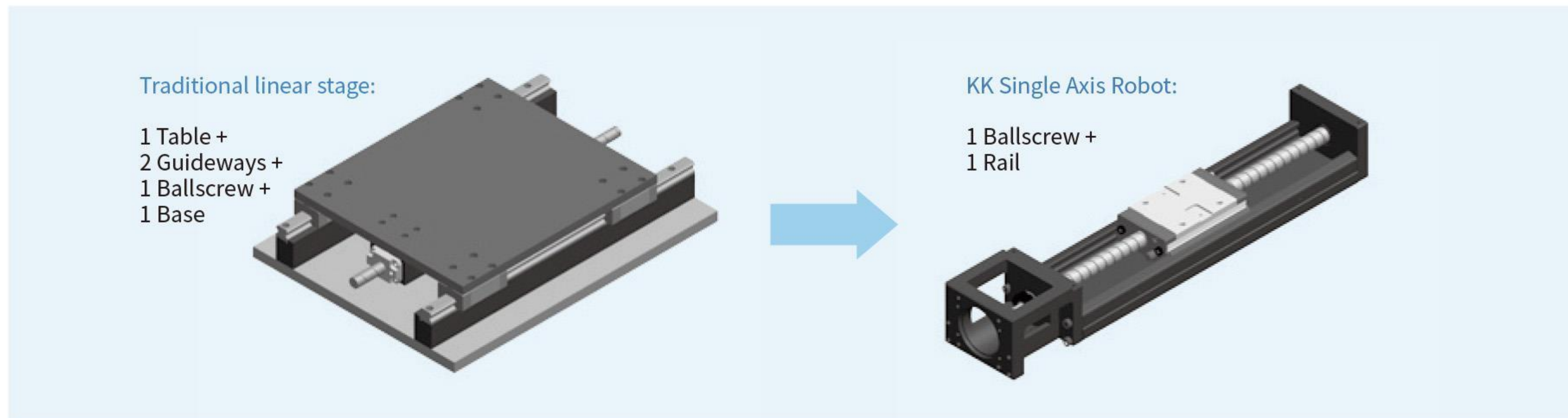

## Equivalent Load

The gothic arch contact design sustains load from all directions and offers high rigidity and accuracy.

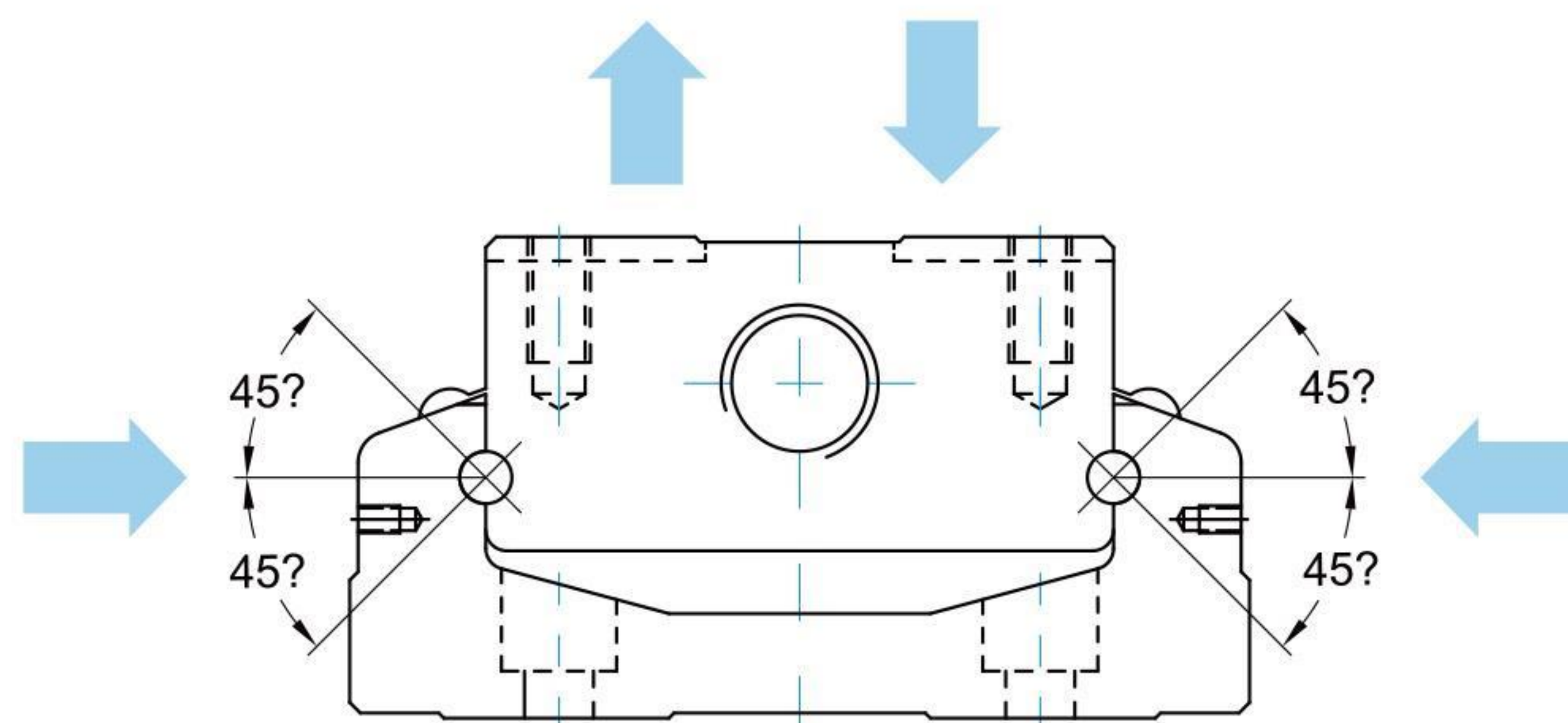

## High Stiffness

Using finite element analysis on the U-shaped cross section allows the volume and rigidity to be made balanced, therefore, a high rigidity rail, compact design and a light weight design are also accomplished simultaneously.

Model no.	$I_x$	$I_y$
KK40	$3.533 \times 10^3$	$5.317 \times 10^4$
KK50	$9.6 \times 10^3$	$1.34 \times 10^5$
KK60	$2.056 \times 10^4$	$2.802 \times 10^5$
KK86	$7.445 \times 10^4$	$1.134 \times 10^6$
KK100	$1.296 \times 10^5$	$2.035 \times 10^6$
KK130	$2.546 \times 10^5$	$5.073 \times 10^6$

IX : Moment of inertia computed about X axis  
 IY : Moment of inertia computed about Y axis

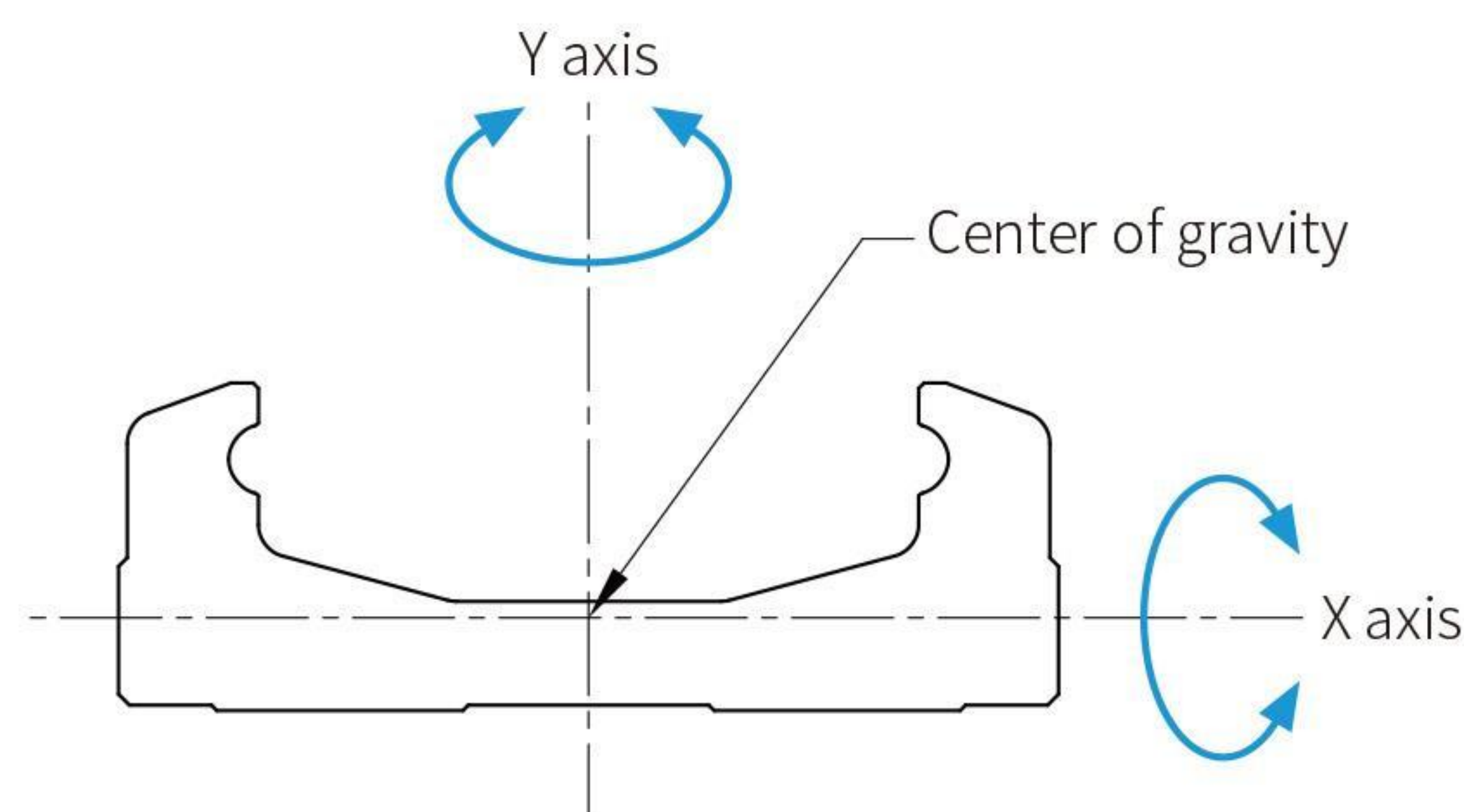

## Various Specification

KK Single Axis Robots of various specifications are developed, providing customers with different choices relating to space and loading conditions.

Model no.	W	H
KK40	40	20
KK50	50	26
KK60	60	33
KK86	86	46
KK100	100	55
KK130	130	65

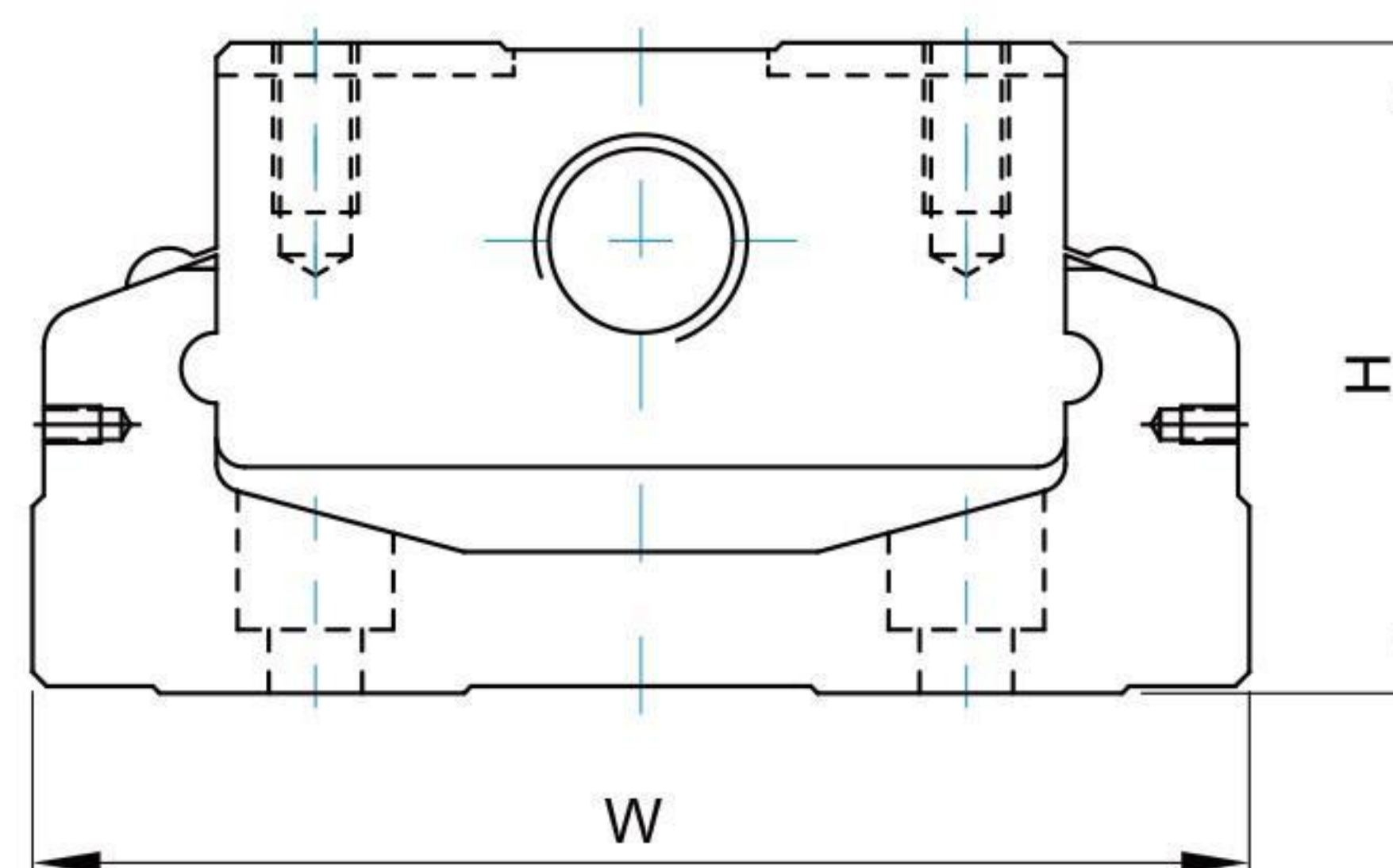





## Accessories

Accessories of KK Single Axis Robot are also supported for specific demands, such as an aluminum cover, bellows, motor adaptor flange and limit switches.

- Aluminum cover and bellow: contamination protection
- Motor adaptor flange: connection for different types of motors
- Limit switches: starting point, positioning and other safety matters

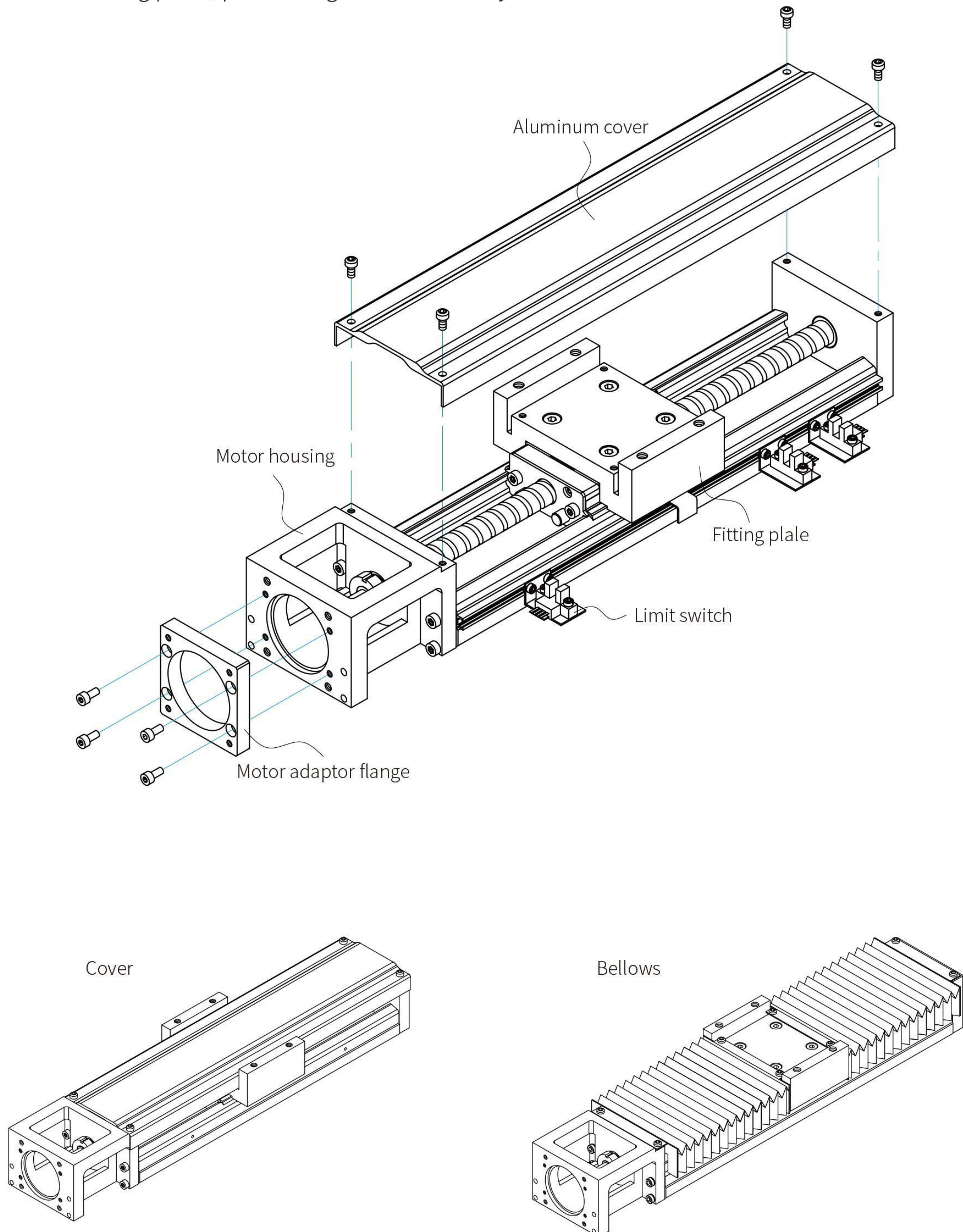



## Model Number of KK Series

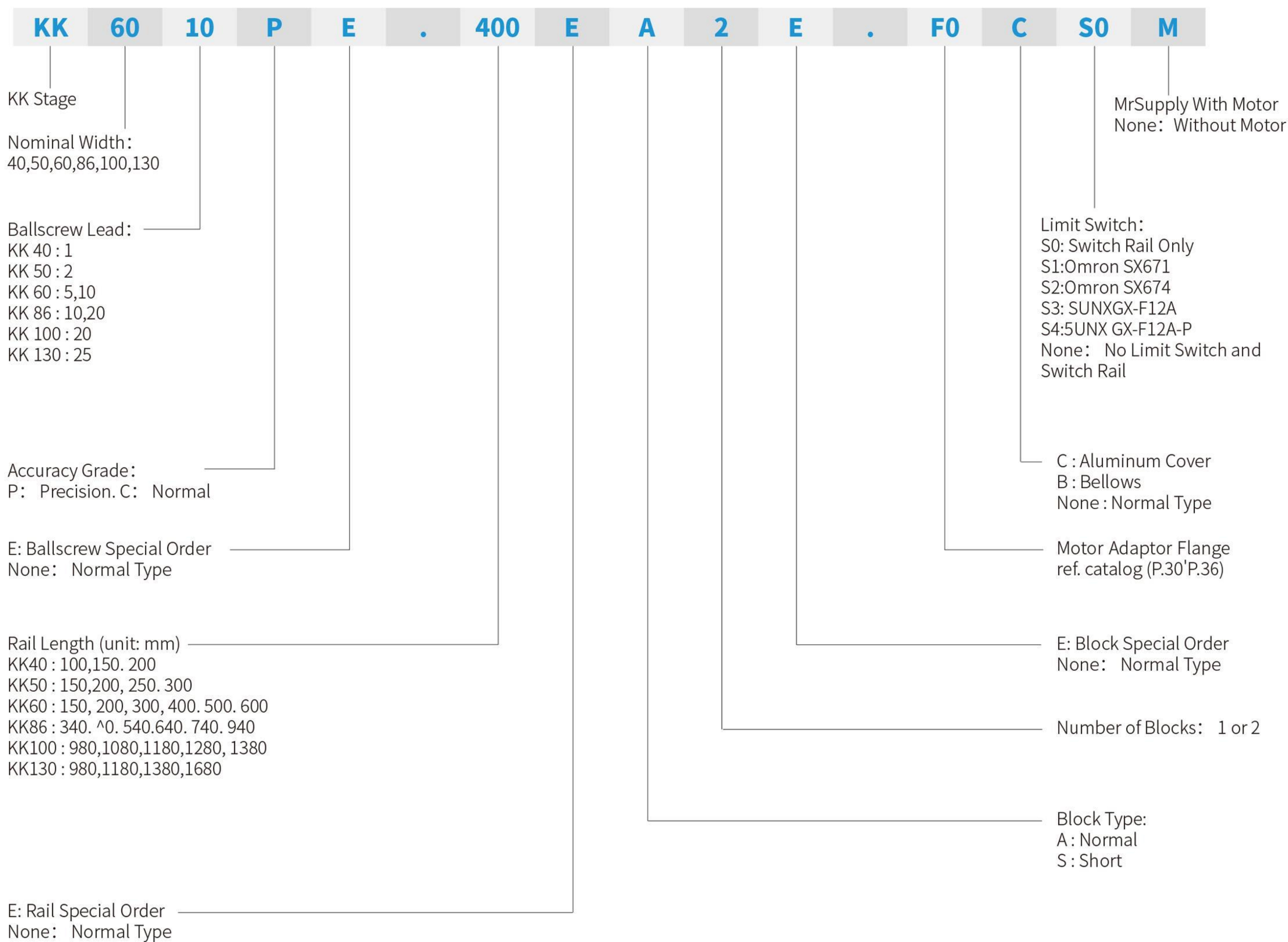



# Specifications

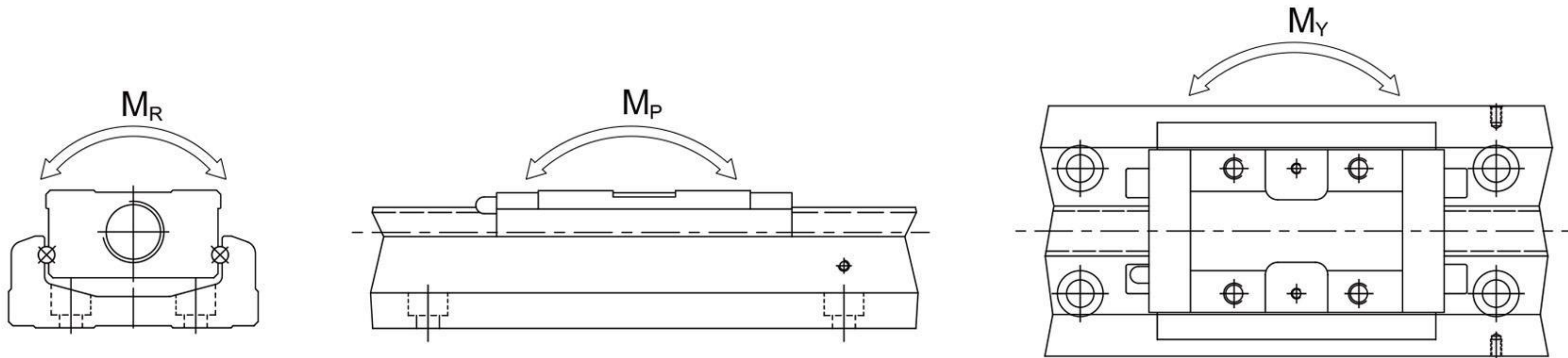

Model No.		Ballscrew				Guideway															
		Nominal Diameter (mm)	Lead (mm)	Basic Dynamic Load (N)	Basic Static Load (N)	Basic Dynamic Load Rating (N)		Basic Static Load Rating (N)		Static Rated Moment											
						Block A	Block S	Block A	Block S	Allowable Static Moment MP (N-m) (pitching)				Allowable Static Moment Mv (N-m) (yawing)				Allowable Static Moment MR(N-m) (rolling)			
				Block A	Block S	Block A1	Block A2	Block S1	Block S2	Block A1	Block A2	Block S1	Block S2	Block A1	Block A2	Block S1	Block S2				
KK4001	Precision	8	1	735	1538	3920	-	6468	-	33	182	-	-	33	182	-	-	81	162	-	-
	Normal			676	1284																
KK5002	Precision	8	2	2136	3489	8007	-	12916	-	116	545	-	-	116	545	-	-	222	444	-	-
	Normal			1813	2910																
KK6005	Precision	12	5	3744	6243	13230	7173	21462	11574	152	760	72	367	152	760	72	367	419	838	241	482
	Normal			3377	5625																
KK6010	Precision	12	10	2410	3743	13230	7173	21462	11574	152	760	72	367	152	760	72	367	419	838	241	482
	Normal			2107	3234																
KK8610	Precision	15	10	7144	12642	31458	21051	50764	29475	622	3050	228	1309	622	3050	228	1309	1507	3014	847	1694
	Normal			6429	11387																
KK8620	Precision	15	20	4645	7655	31458	21051	50764	29475	622	3050	228	1309	622	3050	228	1309	1507	3014	847	1694
	Normal			4175	6889																
KK10020	Precision	20	20	7046	12544	39200	-	63406	-	960	4763	-	-	960	4763	-	-	2205	4410	-	-
	Normal			4782	9163																
KK13025	Precision	20	25	7897	15931	48101	-	84829	-	1536	7350	-	-	1536	7350	-	-	3885	7770	-	-
	Normal			7092	14352																



## Accuracy Grade

Model	Rail Length	Repeatability		Accuracy		Running Parallelism		Starting Torque(N-cm)					
		Precision	Normal	Precision	Normal	Precision	Normal	Precision	Normal				
KK40	100	±0.003	±0.01	0.020	-	0.010	-	1.2	0.8				
	150												
	200												
KK50	150	±0.003	±0.01	0.020	-	0.010	-	4	2				
	200												
	250												
	300												
KK60	150	±0.003	±0.01	0.020	-	0.010	-	15	7				
	200												
	300												
	400												
	500	±0.003	±0.01	0.025	-	0.015	-	15	7				
	600												
KK86	340	±0.003	±0.01	0.025	-	0.015	-	15	10				
	440												
	540												
	640												
	740	±0.003	±0.01	0.030	-	0.020	-	17	10				
	940												
KK100	980	±0.005	±0.01	0.035	-	0.025	-	17	12				
	1080												
	1180	±0.005	±0.01	0.040	-	0.03	-	20	12				
	1280			0.045		0.035		23					
	1380			0.05		0.04		25					
KK130	980	±0.005	±0.01	0.035	-	0.025	-	25	15				
	1180			0.04		0.03		25	15				
	1380			±0.007		±0.012		0.05	-	0.04	-	27	15
	1680												



## Maximum Speed Limit

Model	Ballscrew Lead (mm)	Rail Length (mm)	Speed (mm/sec)	
			Precision	Normal
KK40	01	100	190	190
		150	190	190
		200	190	190
KK50	02	150	270	270
		200	270	270
		250	270	270
		300	270	270
KK60	05	150	550	390
		200	550	390
		300	550	390
		400	550	390
		500	550	390
		600	340	340
	10	150	1100	790
		200	1100	790
		300	1100	790
		400	1100	790
		500	1100	790
		600	670	670
KK86	10	340	740	520
		440	740	520
		540	740	520
		640	740	520
		740	740	520
		940	610	430
	20	340	1480	1050
		440	1480	1050
		540	1480	1050
		640	1480	1050
		740	1480	1050
		940	1220	870
KK100	20	980	1120	800
		1080	980	800
		1180	750	750
		1280	510	630
		1380	440	530
KK130	25	980	1120	800
		1180	1120	800
		1380	830	800
		1680	550	550



## Life Calculations

### Service Life

Under repeated stress between the raceway and the rolling elements, pitting and flaking will occur as it reaches fatigue failure. The service life of the KK Single Axis Robot is defined as the distanced traveled before any failure of the raceway or rolling elements appear.

### Nominal Life (L)

The service life varies greatly even when the KK units are manufactured in the same way or operated under the same conditions. For this reason, nominal life is used as the criteria for predicting the service life of a KK unit.

### Nominal Life Calculation

The calculating formulas are divided into two parts, guideway and ballscrew. The smaller value of the two would be the recommended nominal Life of the KK unit.

Nominal life formulas for both the guideway and ballscrew depend on several parameters and are shown below.

#### Guideway

$$L = \left( \frac{f_t}{f_w} \cdot \frac{C}{P_n} \right)^3 \times 50 \text{ km}$$

L : Life Rating (km)

$f_t$  : Contact Coefficient (ref. Table 1)

$f_w$  : Loading Coefficient (ref. Table 2)

C : Basic Dynamic Load Rating (N)

$P_n$  : Calculated Loading (N)

Table 1

Block Type	Contact Coefficient $f_t$
A1,S1	1.0
A2,S2	0.81

Table 2

Operating Condition		Loading Coefficient $f_t$
Operating Condition	Velocity (V)	
No Thrust	$V < 15\text{m/min}$	1.0 ~ 1.5
Low Vibration	$15\text{m/min} < V < 60\text{m/min}$	1.5 ~ 2.0
High Vibration	$V > 60\text{m/min}$	2.0 ~ 3.5

#### Ballscrew and Bearing

$$L = \left( \frac{1}{f_w} \cdot \frac{C_a}{P_{a,n}} \right)^3 \times 10^6 \text{ rev}$$

L : Life Rating (rev.)

$f_w$  : Loading Coefficient (ref. Table 2)

$C_a$  : Basic Dynamic Load Rating (N)

$P_{a,n}$  : Axial Loading (N)



## Lubrication

Insufficient lubrication of the guideway would lead to a reduction of the service life. The lubricant provides the following functions:

- Reducing rolling friction and avoiding abrasion
- Providing a lubricating film and extending the service life
- Anti-rusting

### Lubricating Grease

Re-lubricating the KK Single Axis Robot every 100km is recommended. Generally, grease is applied for speeds under 60 m/min. For operating speeds over 60 m/min, a grease with a higher viscosity should be used.

$$T = \frac{100 \times 1000}{V_e \times 60}$$

T : Lubricating frequency (hrs)  
Ve : Speed (m/min)

### Grease Nipple

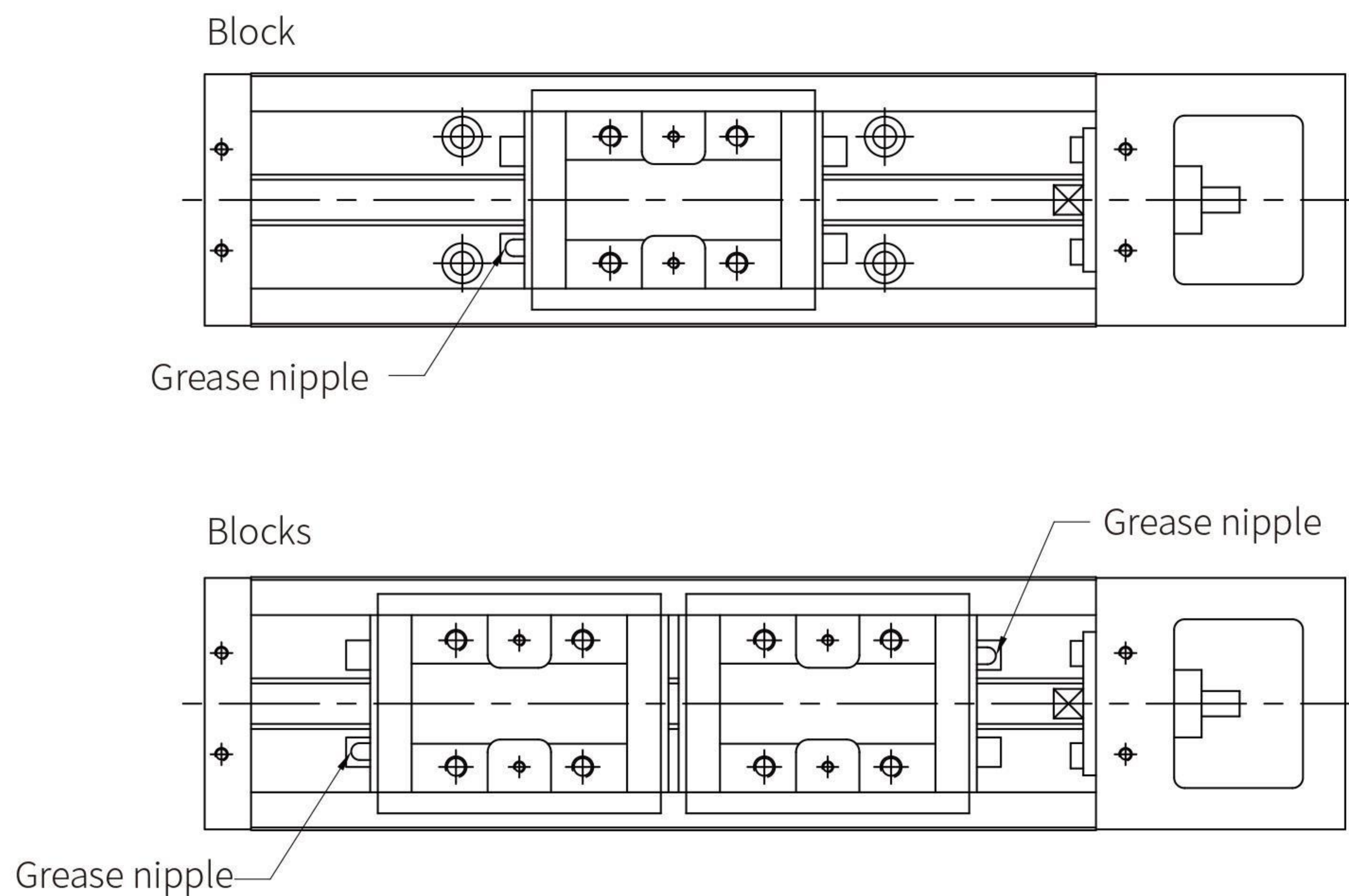



## Dimensions

### Without cover

#### KK40

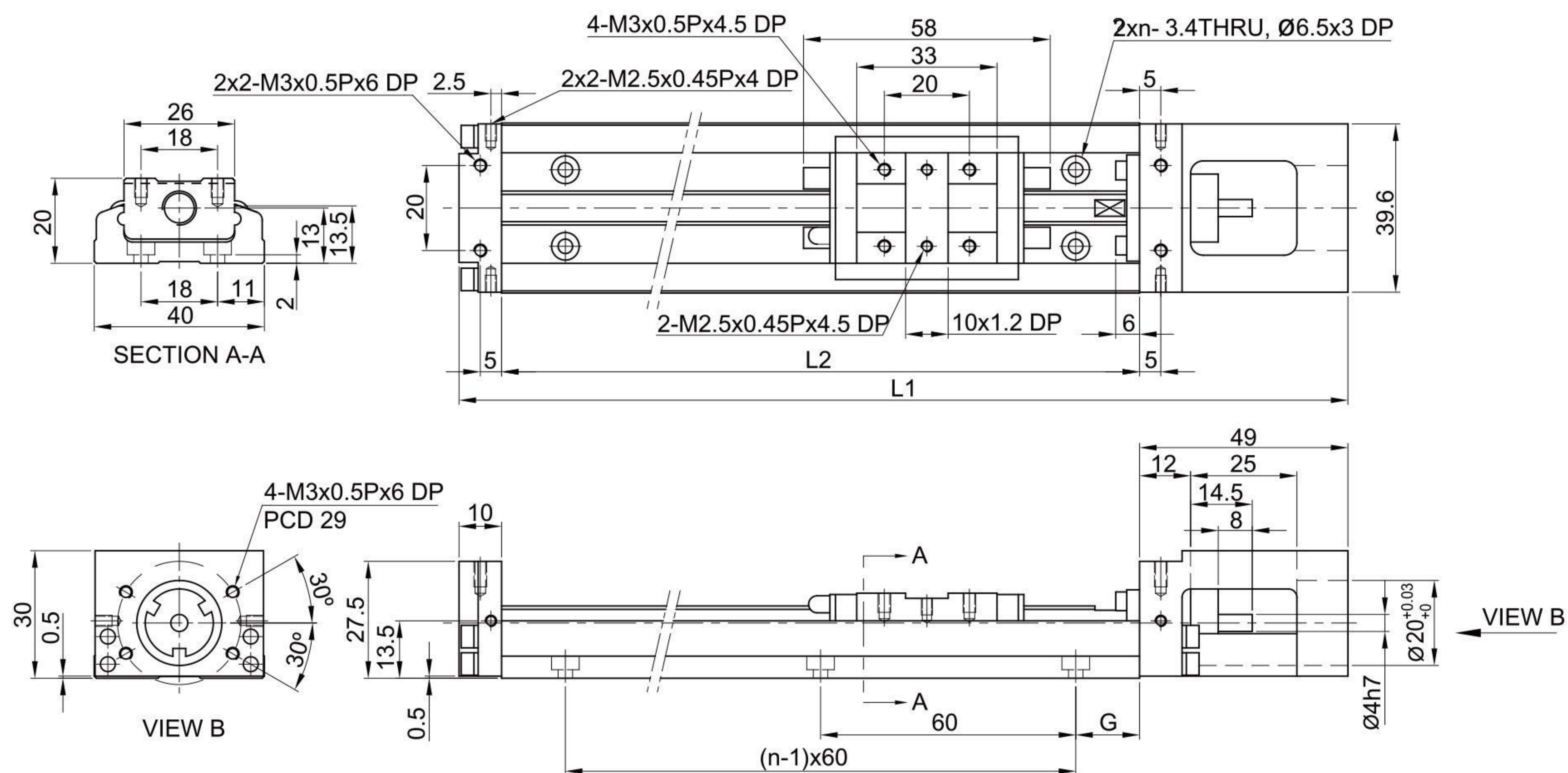

Rail Length L2 (mm)	Total Length L1 (mm)	Maximum Stroke (mm)		G (mm)	n	Mass (kg)	
		A1 Block	A2 Block			A1 Block	A2 Block
100	159	36	-	20	2	0.48	-
150	209	86	34	15	3	0.6	0.67
200	259	136	84	40	3	0.72	0.79

#### KK50

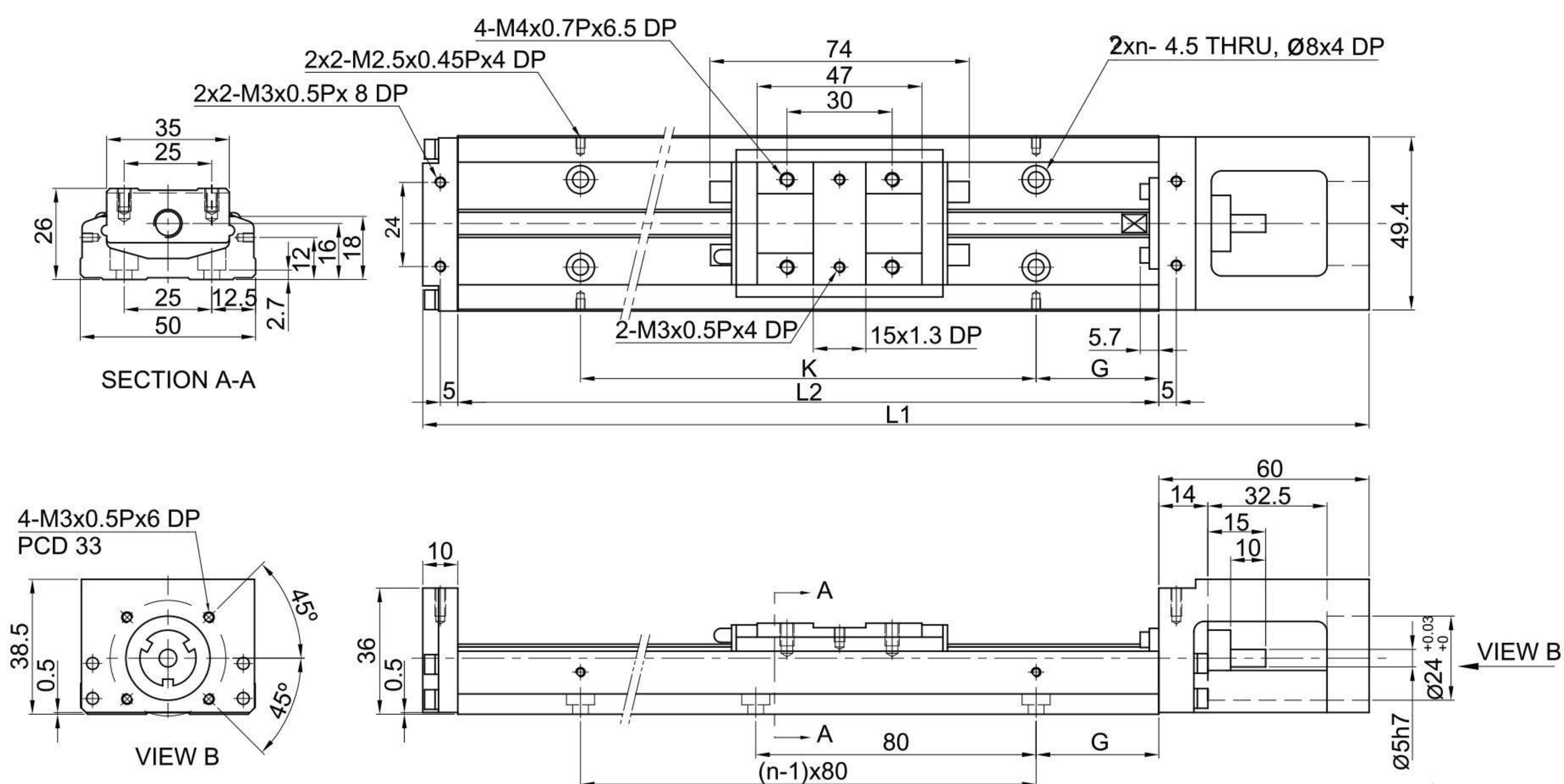

Rail Length L2 (mm)	Total Length L1 (mm)	Maximum Stroke (mm)		G (mm)	K (mm)	n	Mass (kg)	
		A1 Block	A2 Block				A1 Block	A2 Block
150	220	70	-	35	80	2	1	-
200	270	120	55	20	160	3	1.2	1.4
250	320	170	105	45	160	3	1.4	1.6
300	370	220	155	30	240	4	1.6	1.8



## Dimensions

### KK60(Standard)

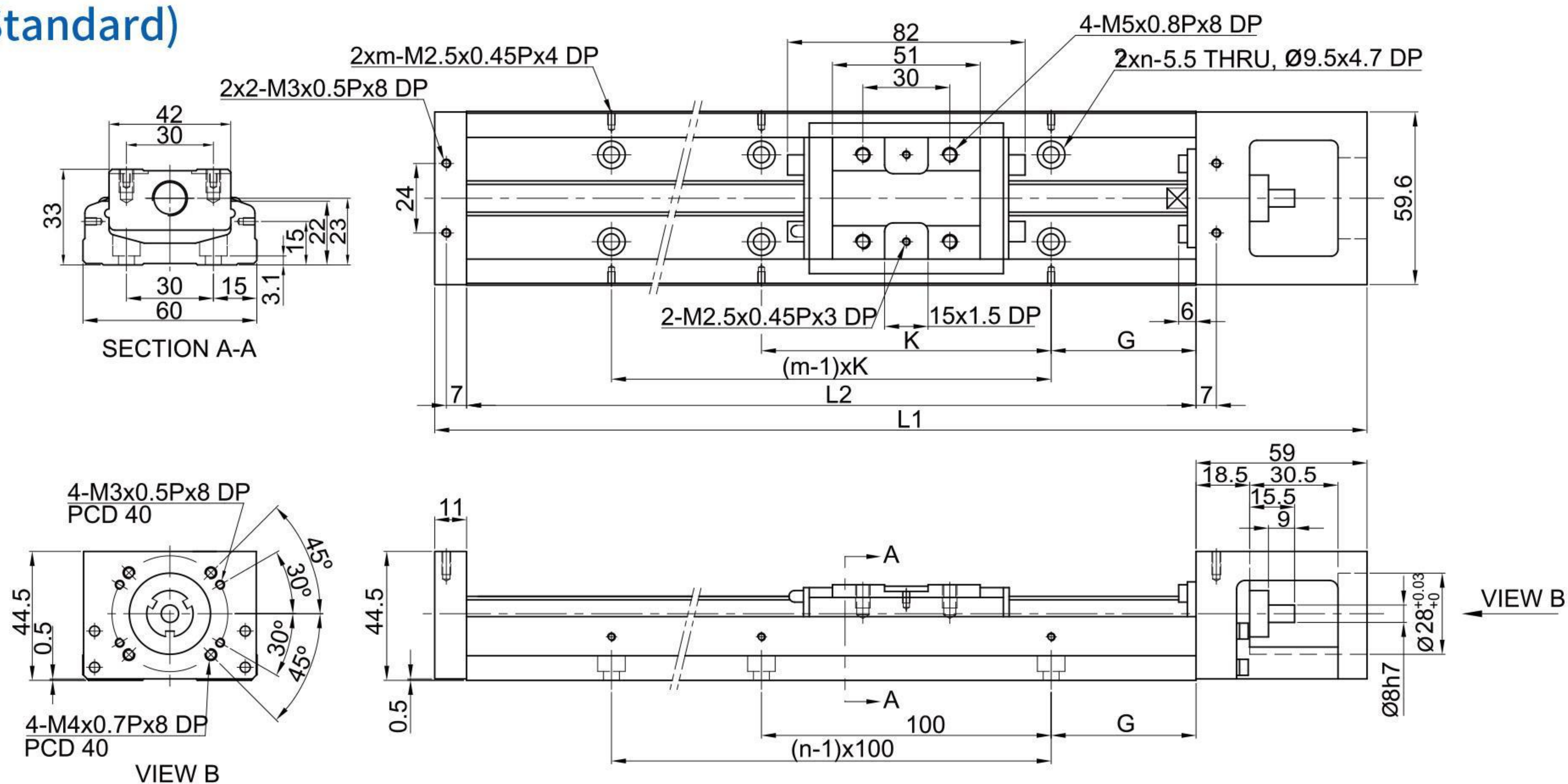

Rail Length L2 (mm)	Total Length L1 (mm)	Maximum Stroke (mm)		G (mm)	K (mm)	n	m	Mass (kg)	
		A1 Block	A2 Block					A1 Block	A2 Block
150	220	60	-	25	100	2	2	1.5	-
200	270	110	-	50	100	2	2	1.8	-
300	370	210	135	50	200	3	2	2.4	2.7
400	470	310	235	50	100	4	4	3	3.3
500	570	410	335	50	200	5	3	3.6	3.9
600	670	510	435	50	100	6	6	4.2	4.6

### KK60(Light Duty)

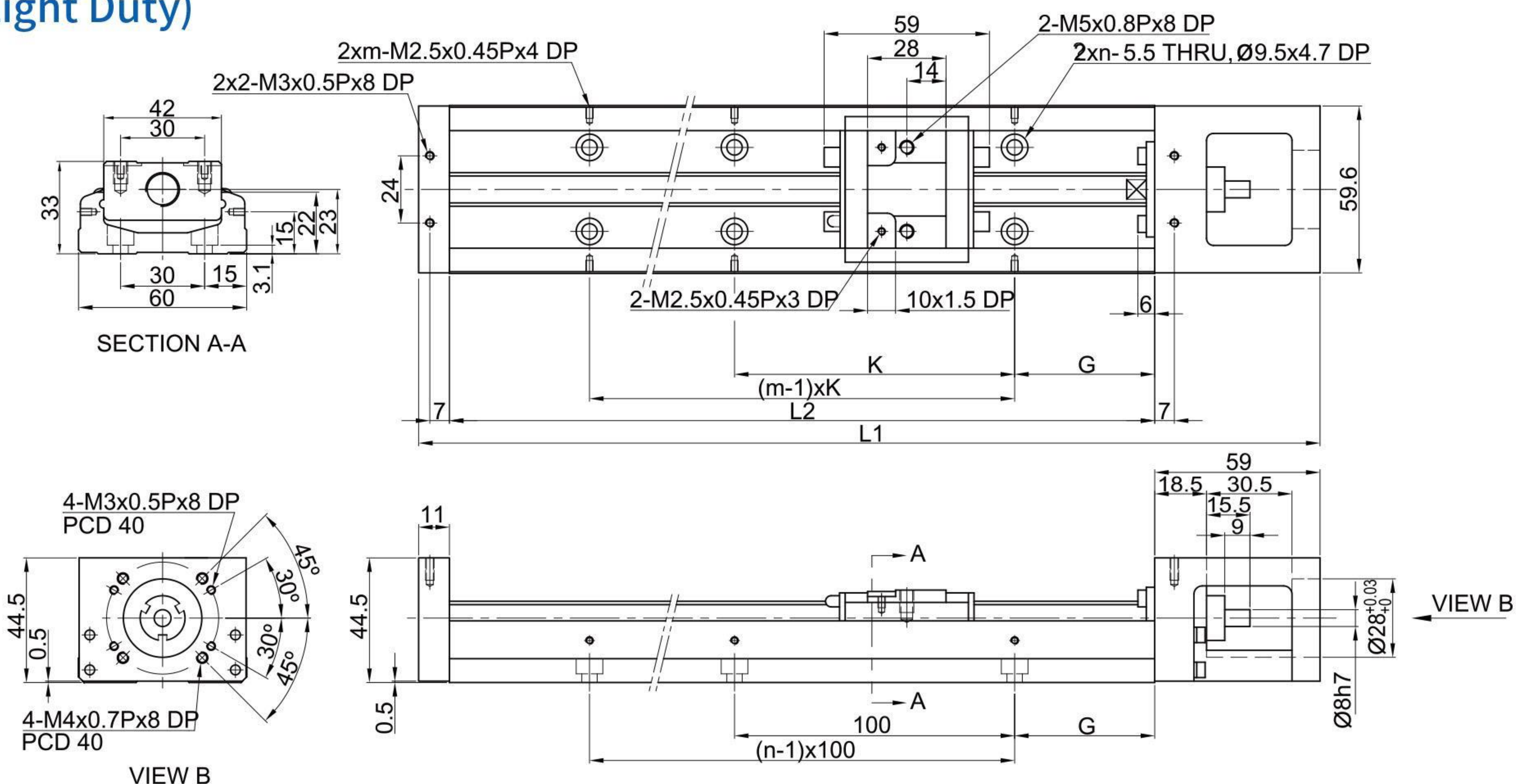

Rail Length L2 (mm)	Total Length L1 (mm)	Maximum Stroke (mm)		G (mm)	K (mm)	n	m	Mass (kg)	
		A1 Block	A2 Block					A1 Block	A2 Block
150	220	85	34	25	100	2	2	1.4	1.6
200	270	135	84	50	100	2	2	1.7	1.9
300	370	235	184	50	200	3	2	2.3	2.5
400	470	335	284	50	100	4	4	2.9	3.1
500	570	435	384	50	200	5	3	3.5	3.7
600	670	535	484	50	100	6	6	4.1	4.3



# Dimensions

## KK86 (Standard)

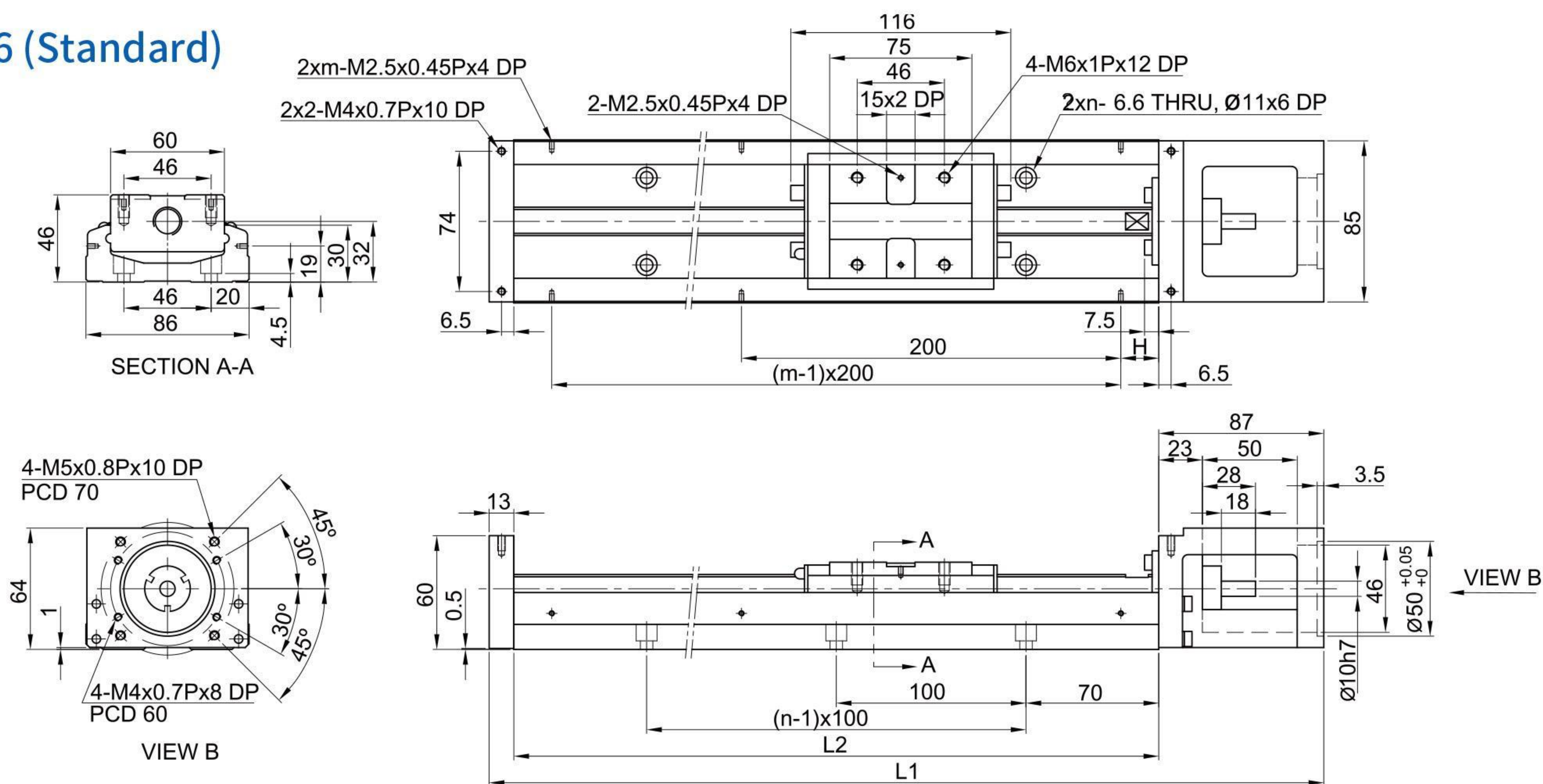

Rail Length L2 (mm)	Total Length L1 (mm)	Maximum Stroke (mm)		H (mm)	n	m	Mass (kg)	
		A1 Block	A2 Block				A1 Block	A2 Block
340	440	210	100	70	3	2	5.7	6.5
440	540	310	200	20	5	3	6.9	7.7
540	640	410	300	70	5	3	8.0	8.8
640	740	510	400	20	7	4	9.2	10.0
740	840	610	500	70	7	4	10.4	11.2
940	1040	810	700	70	9	5	11.6	12.4

## KK86 (Light Duty)

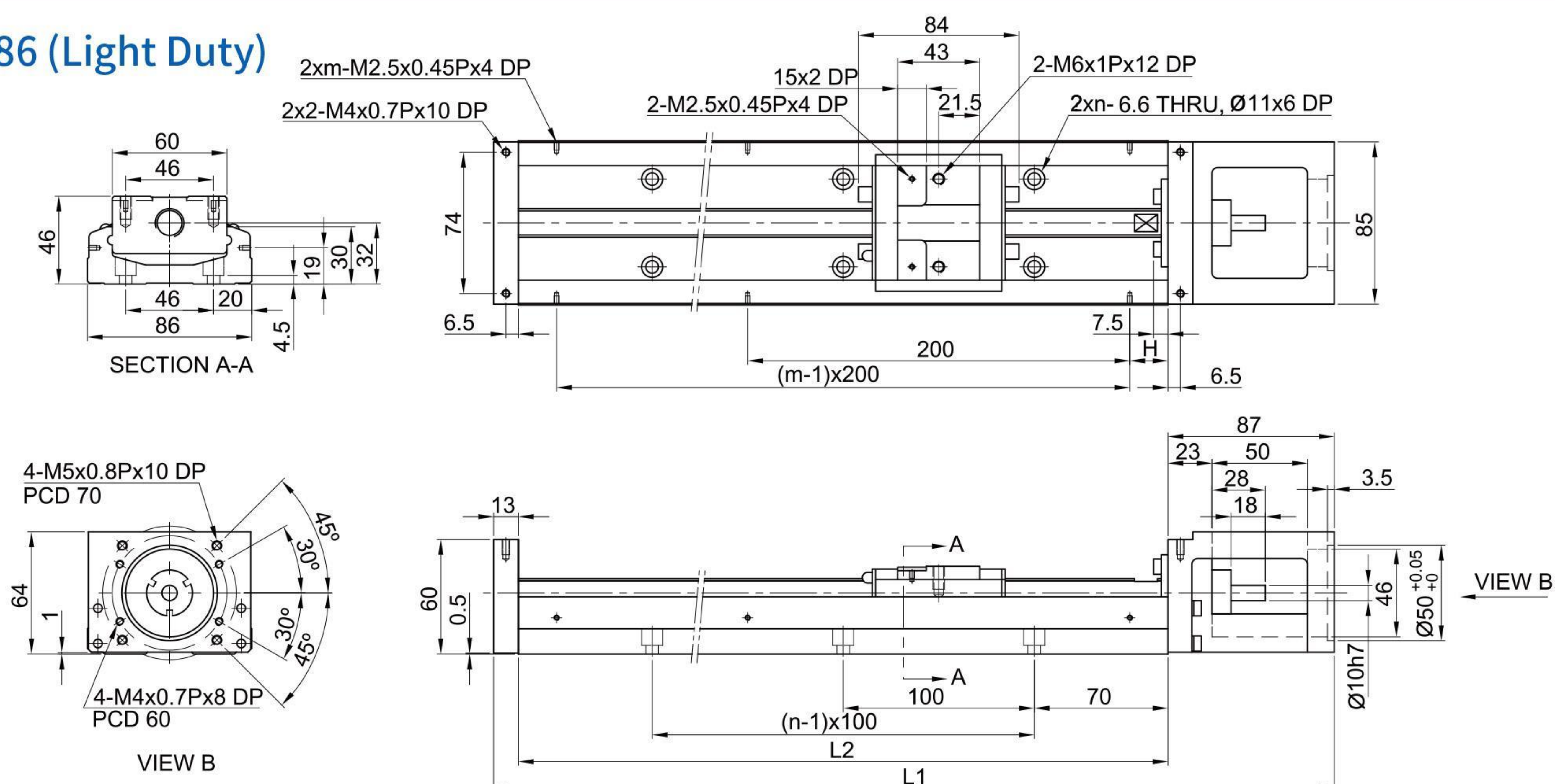

Rail Length L2 (mm)	Total Length L1 (mm)	Maximum Stroke (mm)		H (mm)	n	m	Mass (kg)	
		A1 Block	A2 Block				A1 Block	A2 Block
340	440	246	170	70	3	2	5.4	5.9
440	540	346	270	20	5	3	6.6	7.1
540	640	446	370	70	5	3	7.7	8.2
640	740	546	470	20	7	4	8.9	9.4
740	840	646	570	70	7	4	10.1	10.6
940	1040	846	770	70	9	5	11.3	11.8



# Dimensions

## KK100

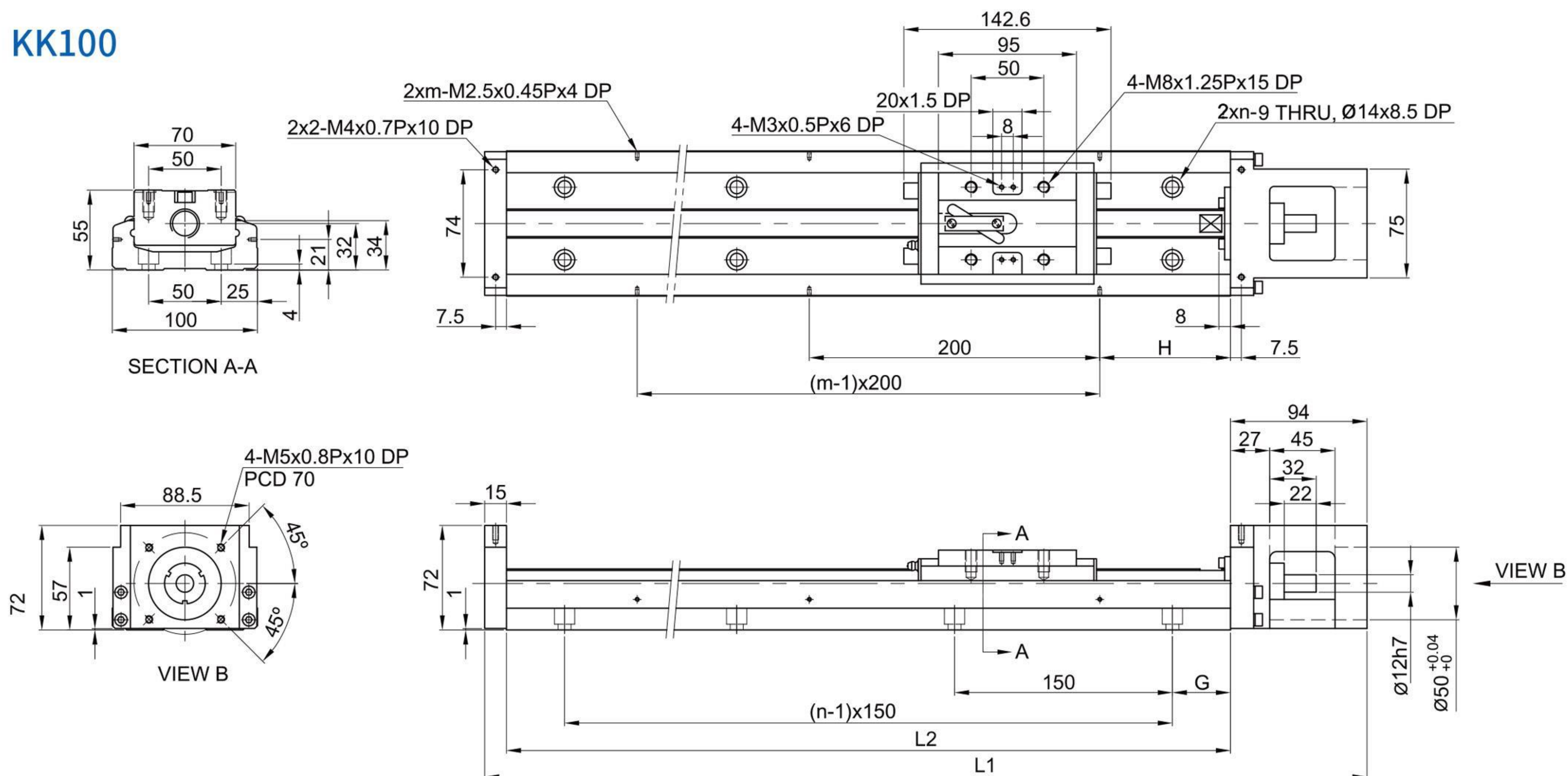

Rail Length L2 (mm)	Total Length L1 (mm)	Maximum Stroke (mm)		G (mm)	K (mm)	n	m	Mass (kg)	
		A1 Block	A2 Block					A1 Block	A2 Block
980	1089	828	700	40	90	7	5	18.6	20.3
1080	1189	928	800	15	40	8	6	20.3	22.0
1180	1289	1028	900	65	90	8	6	22.0	23.7
1280	1389	1128	1000	40	40	9	7	23.6	25.3
1380	1489	1228	1100	15	90	10	7	25.3	27.0

## KK130

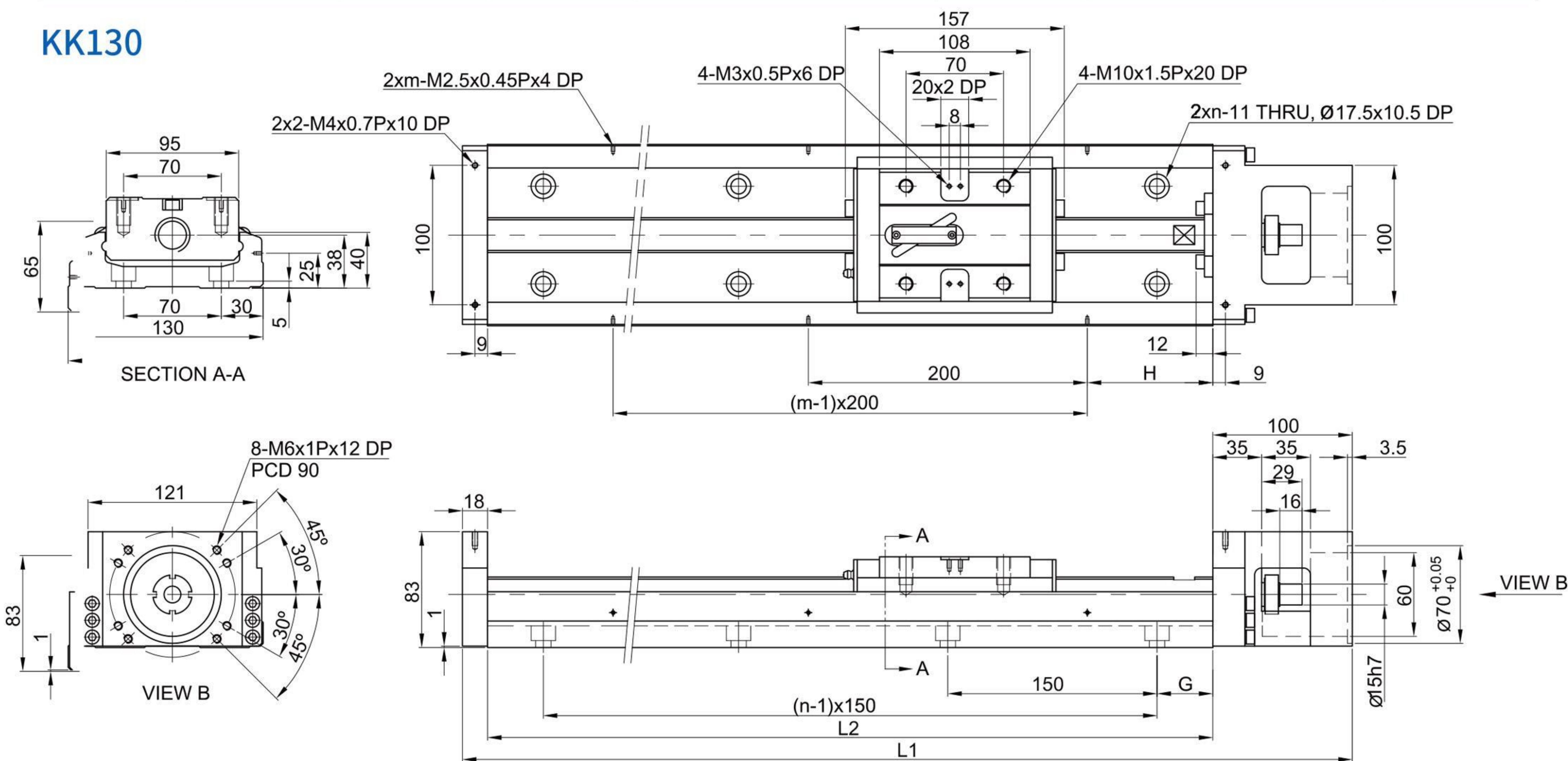

Rail Length L2 (mm)	Total Length L1 (mm)	Maximum Stroke (mm)		G (mm)	K (mm)	n	m	Mass (kg)	
		A1 Block	A2 Block					A1 Block	A2 Block
980	1098	811	659	40	90	7	5	29.4	32.3
1180	1298	1011	859	65	90	8	6	34.3	37.2
1380	1498	1211	1059	90	90	9	7	39.2	42.1
1680	1798	1511	1359	90	40	11	9	46.5	49.4



## Dimensions

Without cover

### KK40

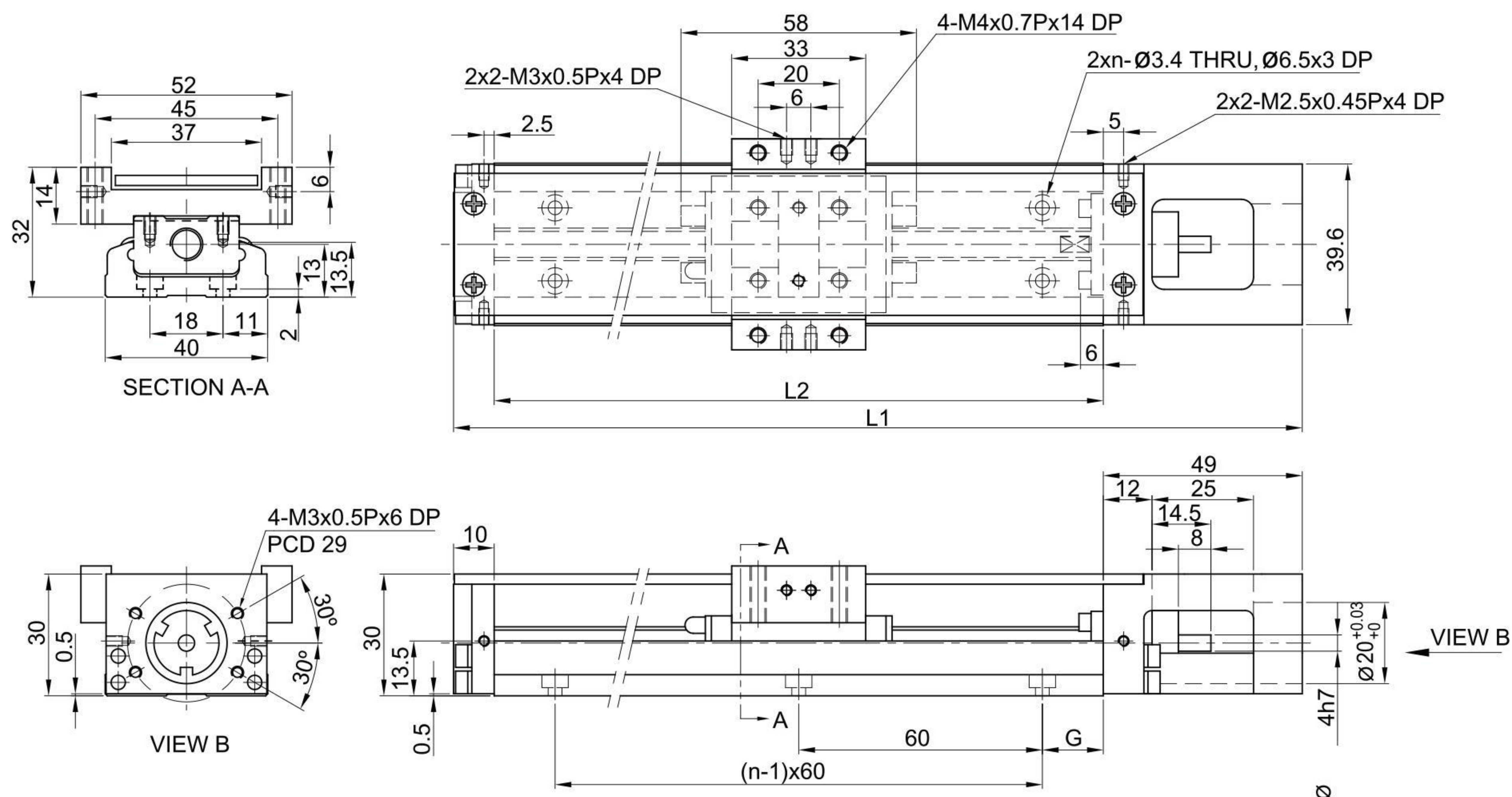

Rail Length L2 (mm)	Total Length L1 (mm)	Maximum Stroke (mm)		G (mm)	n	Mass (kg)	
		A1 Block	A2 Block			A1 Block	A2 Block
100	159	36	-	20	2	0.55	-
150	209	86	34	15	3	0.68	0.76
200	259	136	84	40	3	0.82	0.89

### KK50

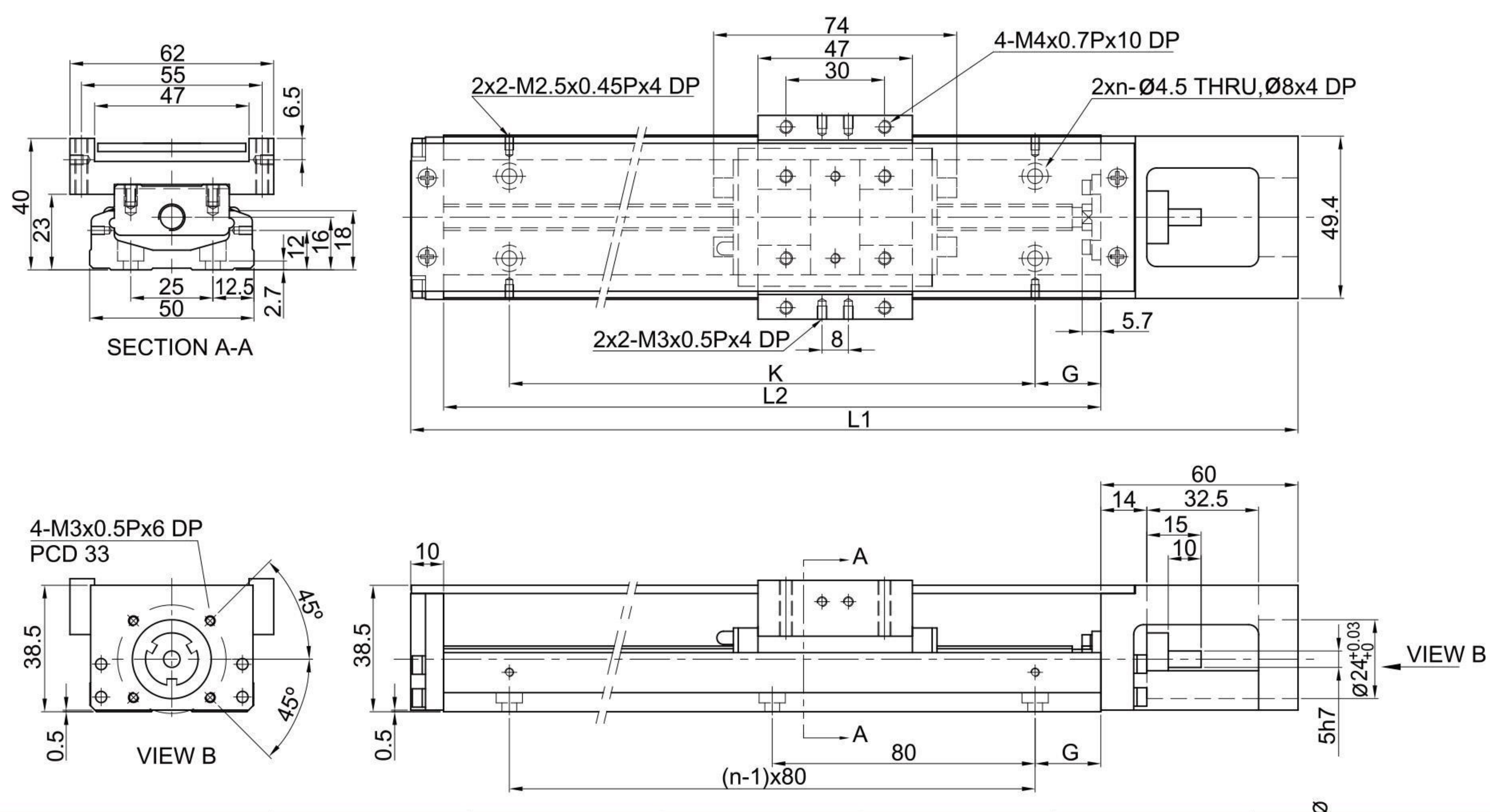

Rail Length L2 (mm)	Total Length L1 (mm)	Maximum Stroke (mm)		G (mm)	K(mm)	n	Mass (kg)	
		A1 Block	A2 Block				A1 Block	A2 Block
150	220	70	-	35	80	2	1.1	-
200	270	120	55	20	160	3	1.3	1.5
250	320	170	105	45	160	3	1.6	1.8
300	370	220	155	30	240	4	1.8	2.0



# Dimensions

## KK60(Standard)

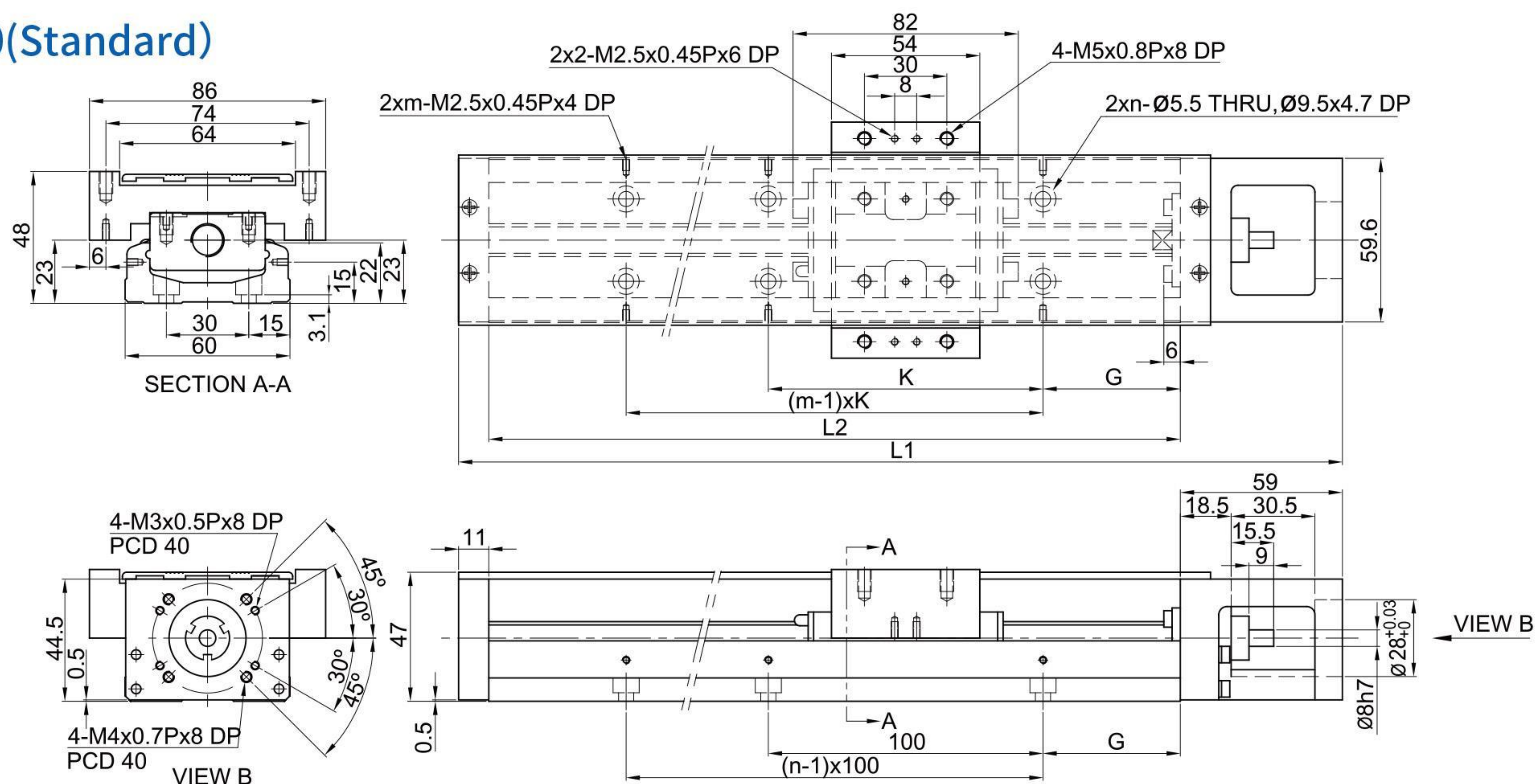

Rail Length L2 (mm)	Total Length L1 (mm)	Maximum Stroke (mm)		G (mm)	K (mm)	n	m	Mass (kg)	
		A1 Block	A2 Block					A1 Block	A2 Block
150	220	60	-	25	100	2	2	1.7	-
200	270	110	-	50	100	2	2	2.1	-
300	370	210	135	50	200	3	2	2.7	3.0
400	470	310	235	50	100	4	4	3.3	3.6
500	570	410	335	50	200	5	3	3.9	4.2
600	670	510	435	50	100	6	6	4.6	5.0

## KK60 (Light Duty)

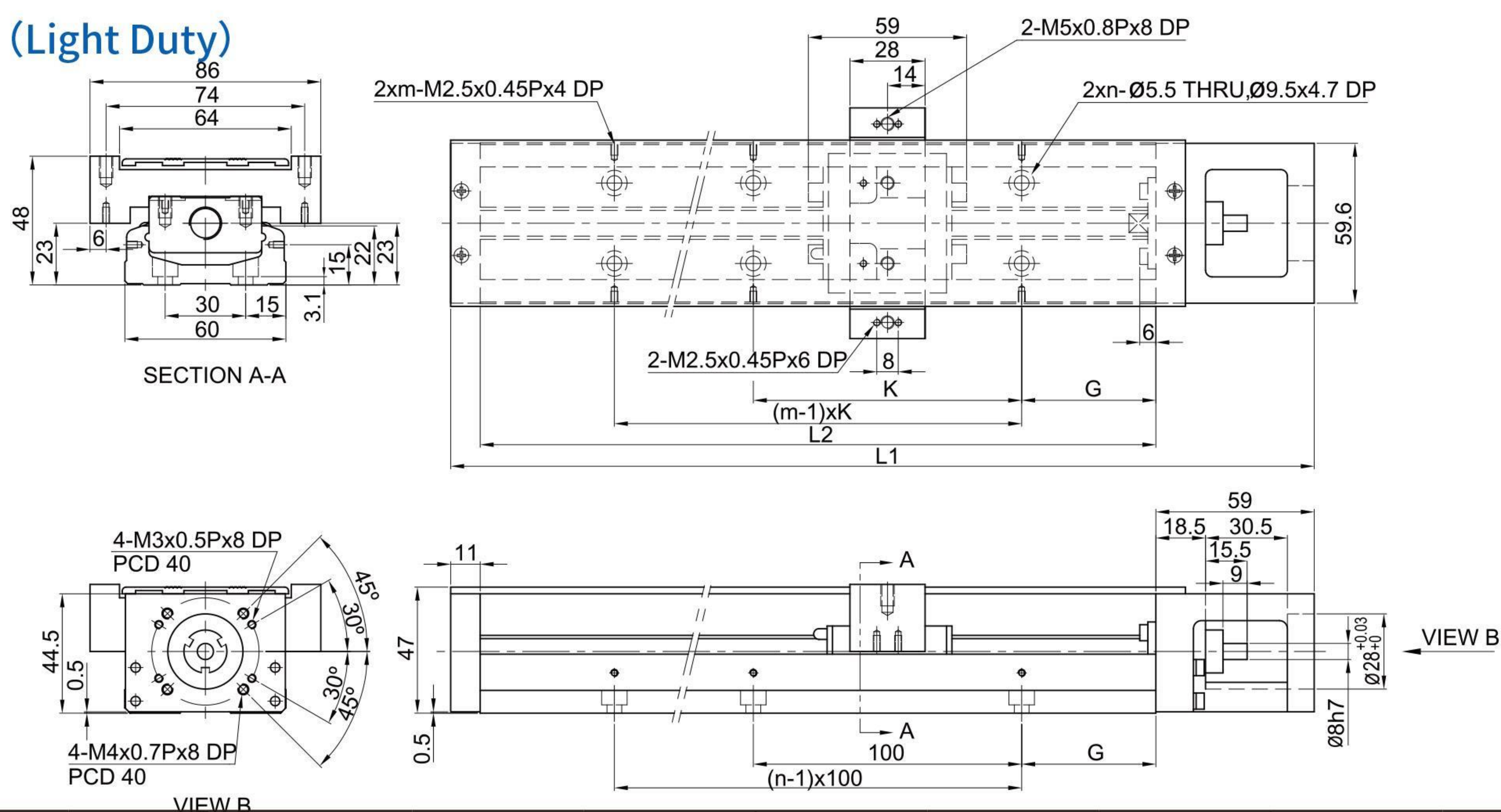

Rail Length L2 (mm)	Total Length L1 (mm)	Maximum Stroke (mm)		G (mm)	K (mm)	n	m	Mass (kg)	
		A1 Block	A2 Block					A1 Block	A2 Block
150	220	85	34	25	100	2	2	1.6	1.8
200	270	135	84	50	100	2	2	1.9	2.1
300	370	235	184	50	200	3	2	2.5	2.7
400	470	335	284	50	100	4	4	3.1	3.3
500	570	435	384	50	200	5	3	3.7	3.9
600	670	535	484	50	100	6	6	4.4	4.6



## Dimensions

### KK86 (Standard)

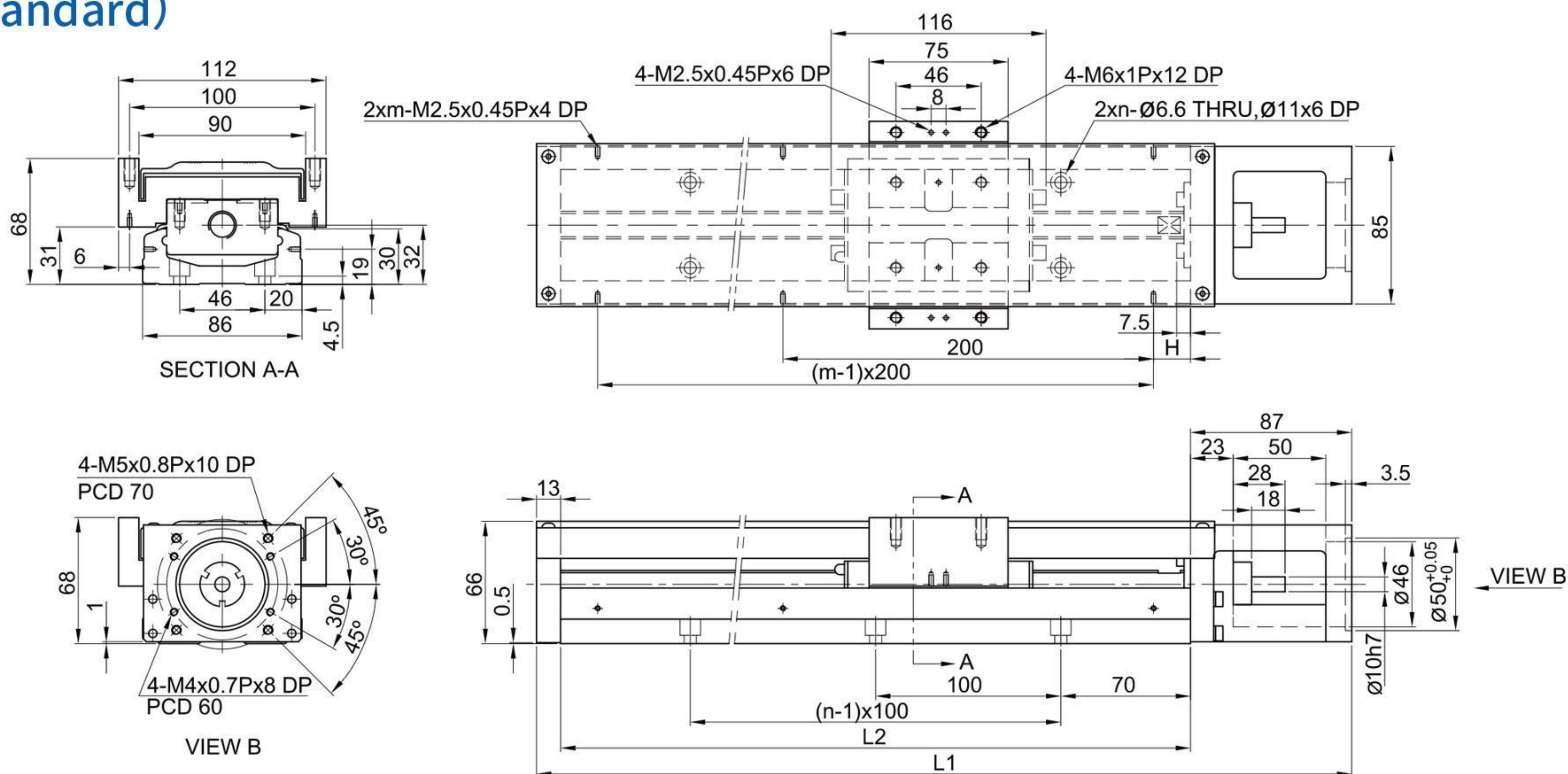

Rail Length L2 (mm)	Total Length L1 (mm)	Maximum Stroke (mm)		H (mm)	n	m	Mass (kg)	
		A1 Block	A2 Block				A1 Block	A2 Block
340	440	210	100	70	3	2	6.5	7.3
440	540	310	200	20	4	3	7.8	8.6
540	640	410	300	70	5	3	9.0	9.8
640	740	510	400	20	6	4	10.3	11.3
740	840	610	500	70	7	4	11.6	12.4
940	1040	810	700	70	9	5	13.0	13.8

### KK86 (Light Duty)

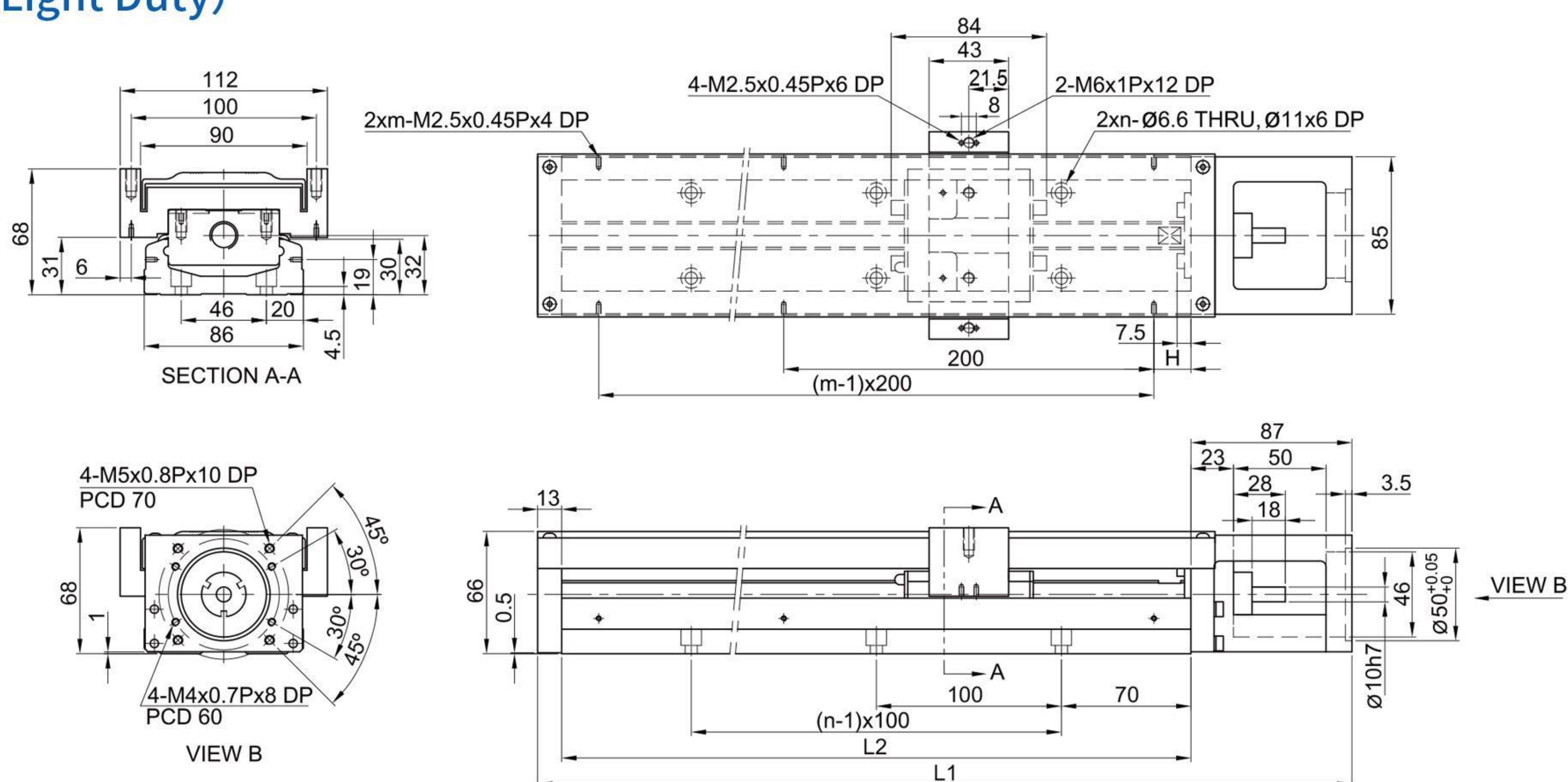

Rail Length L2 (mm)	Total Length L1 (mm)	Maximum Stroke (mm)		H (mm)	n	m	Mass (kg)	
		A1 Block	A2 Block				A1 Block	A2 Block
340	440	246	170	70	3	2	6.3	7.1
440	540	346	270	20	4	3	7.6	8.4
540	640	446	370	70	5	3	8.8	9.6
640	740	546	470	20	6	4	10.1	11.1
740	840	646	570	70	7	4	11.4	12.2
1040	846	770	70	9	5	12.8	13.6	13.8



## Dimensions

### KK86 (Standard)

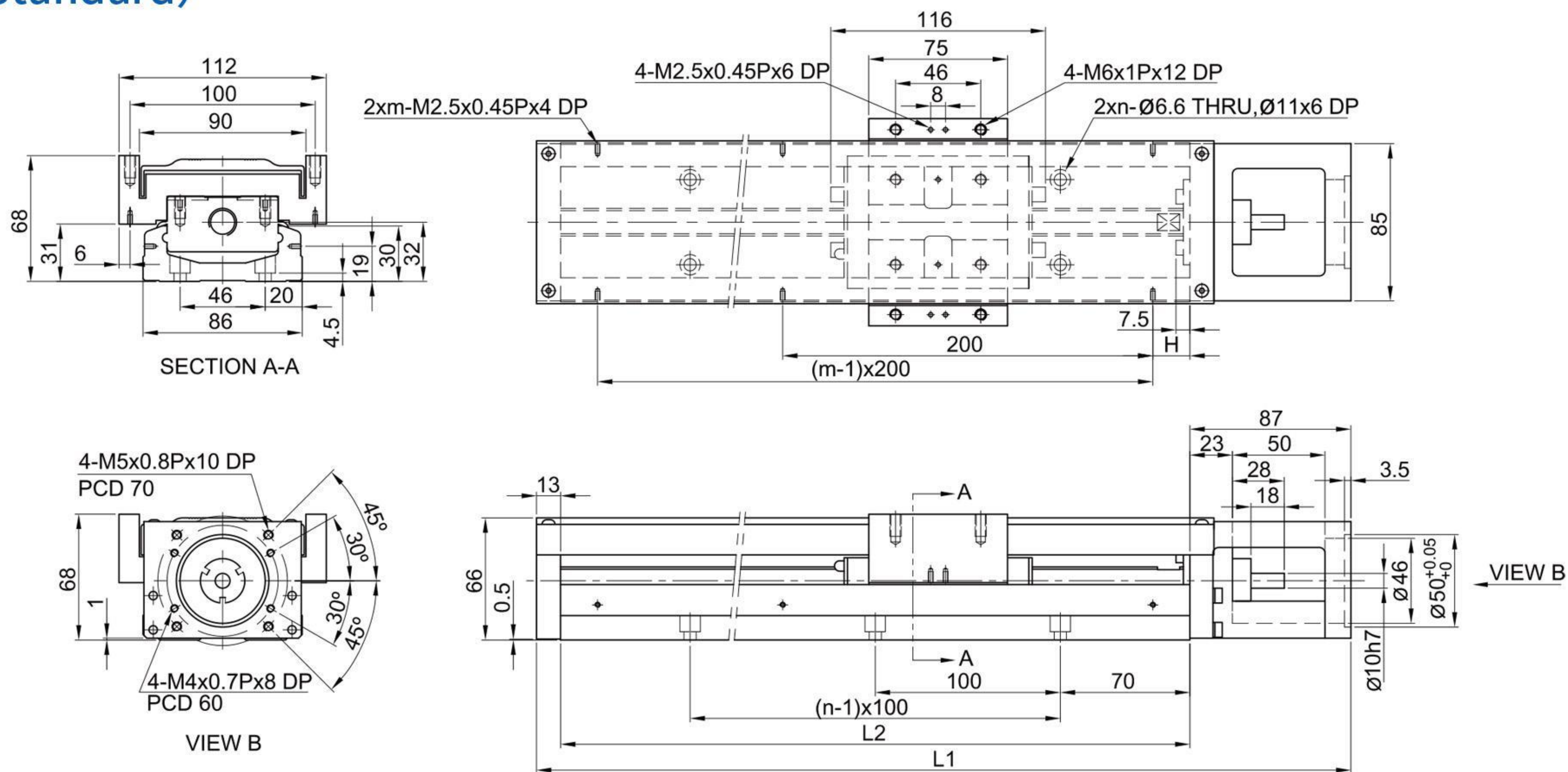

Rail Length L2 (mm)	Total Length L1 (mm)	Maximum Stroke (mm)		H (mm)	n	m	Mass (kg)	
		A1 Block	A2 Block				A1 Block	A2 Block
340	440	210	100	70	3	2	6.5	7.3
440	540	310	200	20	4	3	7.8	8.6
540	640	410	300	70	5	3	9.0	9.8
640	740	510	400	20	6	4	10.3	11.3
740	840	610	500	70	7	4	11.6	12.4
940	1040	810	700	70	9	5	13.0	13.8

### KK86 (Light Duty)

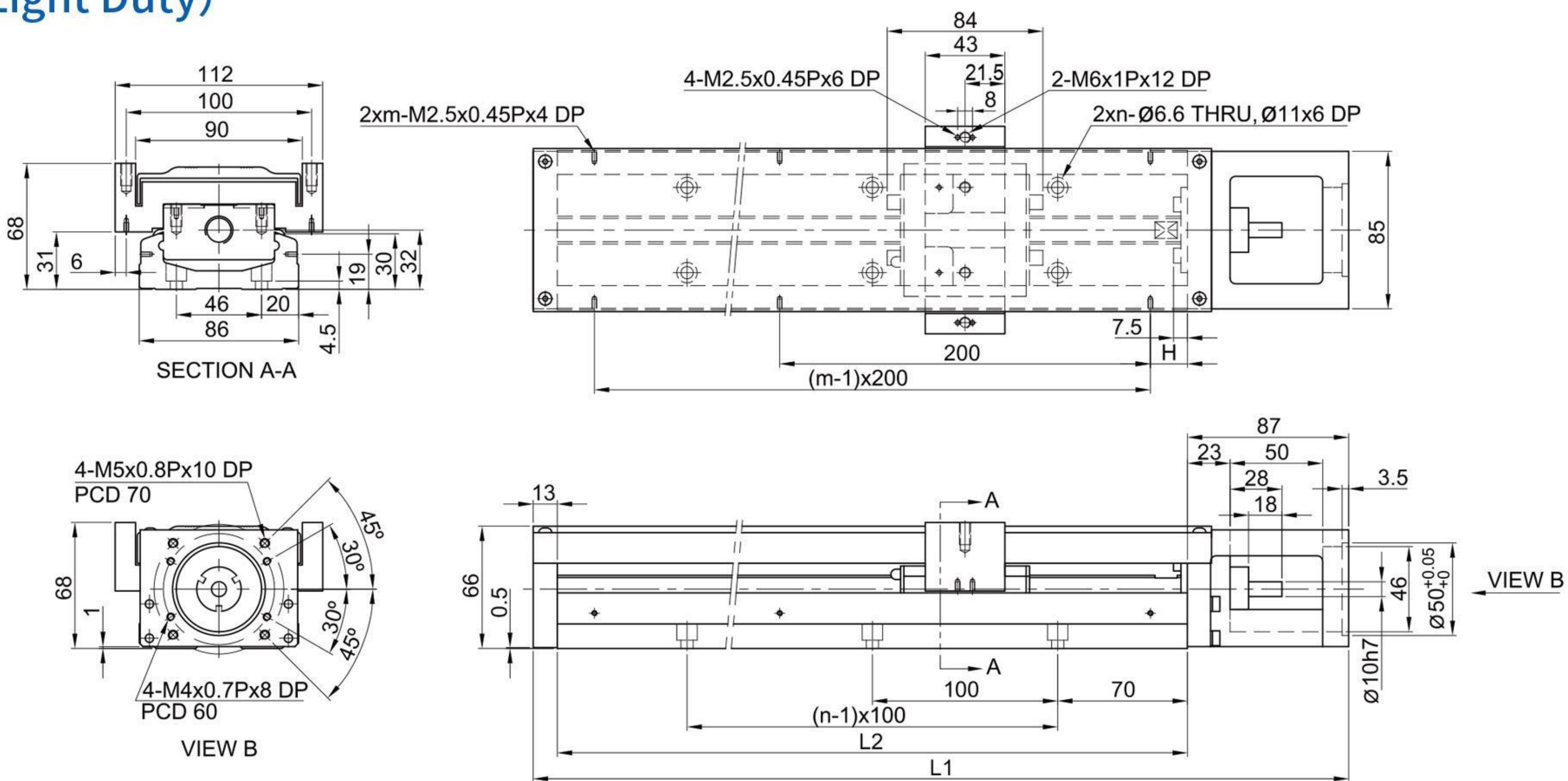

Rail Length L2 (mm)	Total Length L1 (mm)	Maximum Stroke (mm)		H (mm)	n	m	Mass (kg)	
		A1 Block	A2 Block				A1 Block	A2 Block
340	440	246	170	70	3	2	6.3	7.1
440	540	346	270	20	4	3	7.6	8.4
540	640	446	370	70	5	3	8.8	9.6
640	740	546	470	20	6	4	10.1	11.1
740	840	646	570	70	7	4	11.4	12.2
1040	846	770	70	9	5	12.8	13.6	13.8



## Dimensions

### Motor Selection

#### ALM Mikrosystem Servo Motor

Motor Output	Motor	Weight (kg)	Flange Selection						Brake Weight (Kg)	Driver	Weight (kg)	Remarks
			KK40	KK50	KK60	KK86	KK100	KK130				
100W	FRAC101022	0.6	F2	F2	F2	F3	-	-	-	MD-36-S	1.25	220V
200W	FRAC102022	1	-	-	-	F0	F0	F1	-			220V
400W	FRAC104022	1.45	-	-	-	F0	F0	F1	-			220V
750W	FRAC107522	2.66	-	-	-	-	F1	F2	-			220V

#### Mitsubishi Servo Motor

Motor Output	Motor	Weight (kg)	Flange Selection						Brake Weight (Kg)	Driver	Weight (kg)	Remarks
			KK40	KK50	KK60	KK86	KK100	KK130				
50W	HF-KP053	0.35	F1	F1	F1	F2	-	-	0.75	MR-J3S-10A	0.8	220V
100W	HF-KP13	0.56	F1	F1	F1	F2	-	-	0.89	MR-J3S-10A	0.8	220V
200W	HF-KP23	0.94	-	-	-	F0	F0	F1	1.6	MR-J3S-20A	0.8	220V
400W	HF-KP43	1.5	-	-	-	F0	F0	F1	2.1	MR-J3S-40A	1	220V
750W	HF-KP73	2.9	-	-	-	-	F1	F2	4	MR-J3S-70A	1.4	220V

#### Panasonic Servo Motor

Motor Output	Motor	Weight (kg)	Flange Selection						Brake Weight (Kg)	Driver	Weight (kg)	Remarks
			KK40	KK50	KK60	KK86	KK100	KK130				
50W	MSMD5AZP1	0.32	F2	F2	F2	F3	-	-	0.53	MADDT1105	0.8	110V
50W	MSMD5AZP1	0.32	F2	F2	F2	F3	-	-	0.53	MADDT1205	0.8	220V
100W	MSMD011P1	0.47	F2	F2	F2	F3	-	-	0.68	MADDT1107	0.8	110V
100W	MSMD012P1	0.47	F2	F2	F2	F3	-	-	0.68	MADDT1205	0.8	220V
200W	MSMD021P1	0.82	-	-	-	F1	-	-	1.3	MADDT2110	1.1	110V
200W	MSMD022P1	0.82	-	-	-	F1	-	-	1.3	MADDT1207	0.8	220V
400W	MSMD041P1	1.2	-	-	-	F1	-	-	1.7	MADDT3120	1.5	110V
400W	MSMD042P1	1.2	-	-	-	F1	-	-	1.7	MADDT2210	1.1	220V
750W	MSMD082S1	2.3	-	-	-	F4	F2	F4	3.1	MADDT3520	1.5	220V

#### Yasukawa Servo Motor

Motor Output	Motor	Weight (kg)	Flange Selection						Brake Weight (Kg)	Driver	Weight (kg)	Remarks
			KK40	KK50	KK60	KK86	KK100	KK130				
50W	SGMAV-A5ADA61	0.3	F1	F1	F1	F2	-	-		SGDV-R70A01A	0.9	with key
50W	SGMAV-A5ADA2C	0.3	F1	F1	F1	F2	-	-		SGDV-R70A01A	0.9	no key
50W	SGMAV-A5ADA21	0.3	F1	F1	F1	F2	-	-	0.75	SGDV-R70A01A	0.9	Mid inertia
100W	SGMAV-01ADA64	0.4	F1	F1	F1	F2	-	-	0.89	SGDV-R90A01A	0.9	
200W	SGMAV-02ADA65	0.9	-	-	-	F0	F0	F1	1.6	SGDV-1R6A01A	0.9	
400W	SGMAV-04ADA66	1.2	-	-	-	F0	F0	F1	2.1	SGDV-2R8A01A	1	
750W	SGMAV-08ADA67	2.6	-	-	-	-	F1	F2	4	SGDV-5R5A01A	1.5	



## Dimensions

### ALM Mikosystem Step Motor

Series	Model	Flange Selection						Weight (kg)	Built in Motor	Weight (kg)	Remarks	
		KK40	KK50	KK60	KK86	KK100	KK130					
AL40	FRST011024	F3	F3	F5	-	-	-	0.3	STD-24A	0.09	single axis	
AL55	FRST021024	F3	F3	F5	-	-	-	0.55			single axis	
	FRST022024				-	-	-	0.8				
	FRST023024				-	-	-	1.18				
	FRST121024	F3	F3	F5	-	-	-	0.58				axis of symmetry
	FRST122024				-	-	-	0.83				
	FRST123024				-	-	-	0.21				

### Oriental Step Motor

Series	Model	Flange Selection						Built in Motor	Weight (kg)	Built in Motor	Weight (kg)
		KK40	KK50	KK60	KK86	KK100	KK130				
CSK 2 phase	CSK243-AP	F3	F3	F5	-	-	-	PK243-01A	0.21	CSD2109-P	0.12
	CSK244-AP	F3	F3	F5	-	-	-	PK244-01A	0.27	CSD2112-P	0.12
	CSK245-AP	F3	F3	F5	-	-	-	PK245-01A	0.35	CSD2112-P	0.12
	CSK264-AP	-	-	F4	F6	-	-	PK264-02A	0.45	CSD2120-P	0.12
	CSK266-AP	-	-	F4	F6	-	-	PK266-02A	0.7	CSD2120-P	0.12
	CSK268-AP	-	-	F4	F6	-	-	PK268-02A	1	CSD2120-P	0.12
	CSK296-AP	-	-	-	-	F4	F3	PK296-03A	1.7	CSD2145P	0.2
	CSK299-AP	-	-	-	-	F4	F3	PK299-03A	2.8	CSD2145P	0.2
	CSK2913-AP	-	-	-	-	F4	F3	PK2913-02A	3.8	CSD2140P	0.2
CFKII 5 phase micro stepping	CFK543AP2	F3	F3	F5	-	-	-	PK543NAW	0.21	DFC5107P	0.2
	CFK544AP2	F3	F3	F5	-	-	-	PK544NAW	0.27	DFC5107P	0.2
	CFK545AP2	F3	F3	F5	-	-	-	PK545NAW	0.35	DFC5107P	0.2
	CFK564AP2	-	-	-	F5	-	-	PK564NAW	0.6	DFC5114P	0.2
	CFK566AP2	-	-	-	F5	-	-	PK566NAW	0.8	DFC5114P	0.2
	CFK569AP2	-	-	-	F5	-	-	PK569NAW	1.3	DFC5114P	0.2
	CFK566HAP2	-	-	-	F5	-	-	PK566HNAW	0.8	DFC5128P	0.22
	CFK569HAP2	-	-	-	F5	-	-	PK569HNAW	1.3	DFC5128P	0.22
	CFK596HAP2	-	-	-	-	F3	-	PK596HNAW	1.7	DFC5128P	0.22
	CFK599HAP2	-	-	-	-	F3	-	PK599HNAW	2.8	DFC5128P	0.22
	CFK5913HAP2	-	-	-	-	F3	-	PK5913HNAW	3.8	DFC5128P	0.22
UMK 2 phase	UMK243A	F3	F3	F5	-	-	-	PK243-01	0.21	UDK2109	0.47
	UMK244A	F3	F3	F5	-	-	-	PK244-01	0.27	UDK2112	0.47
	UMK245A	F3	F3	F5	-	-	-	PK245-01	0.35	UDK2112	0.47
	UMK264A	-	-	F4	F6	-	-	PK264-02	0.45	UDK2120	0.47
	UMK266A	-	-	F4	F6	-	-	PK266-02	0.7	UDK2120	0.47
	UMK268A	-	-	F4	F6	-	-	PK268-02	1	UDK2120	0.47
RK 5 phase	RK543AA	F3	F3	F5	-	-	-	PK543W	0.25	RKD507-A	0.4
	RK544AA	F3	F3	F5	-	-	-	PK544W	0.3	RKD507-A	0.4
	RK545AA	F3	F3	F5	-	-	-	PK545W	0.4	RKD507-A	0.4
	RK566AA	-	-	-	F5	-	-	PK566W	0.8	RKD514L-A	0.85
	RK569AA	-	-	-	F5	-	-	PK569W	1.3	RKD514L-A	0.85
	RK596AA	-	-	-	-	F3	-	PK596W	1.7	RKD514H-A	0.85
	RK599AA	-	-	-	-	F3	-	PK599W	2.8	RKD514H-A	0.85
	RK5913AA	-	-	-	-	F3	-	PK5913W	3.8	RKD514H-A	0.85



# Dimensions

## KK40

Motor Housing F0

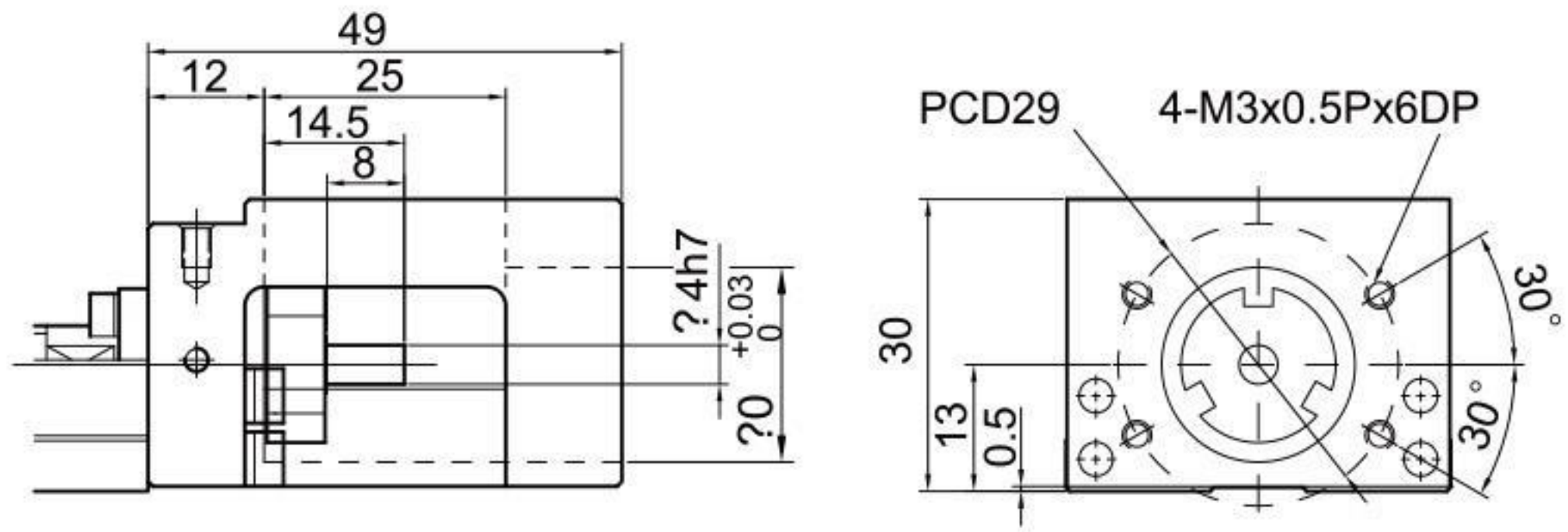

Motor Adaptor Flange F1

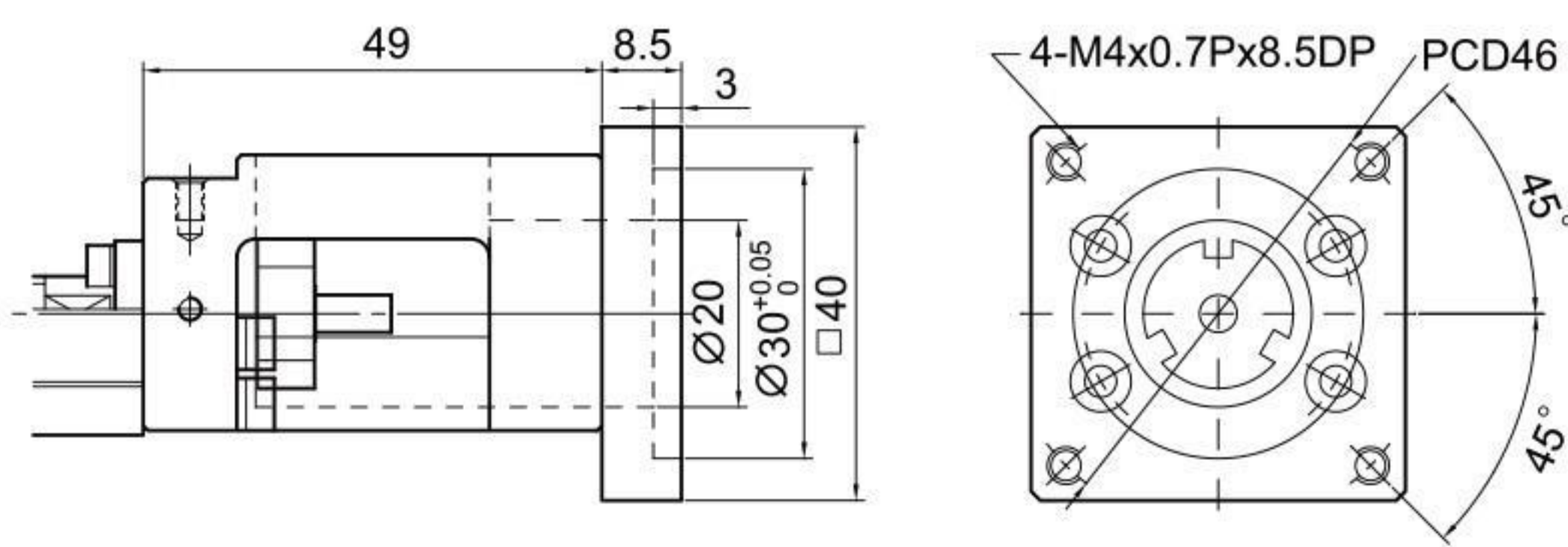

Motor Adaptor Flange F3

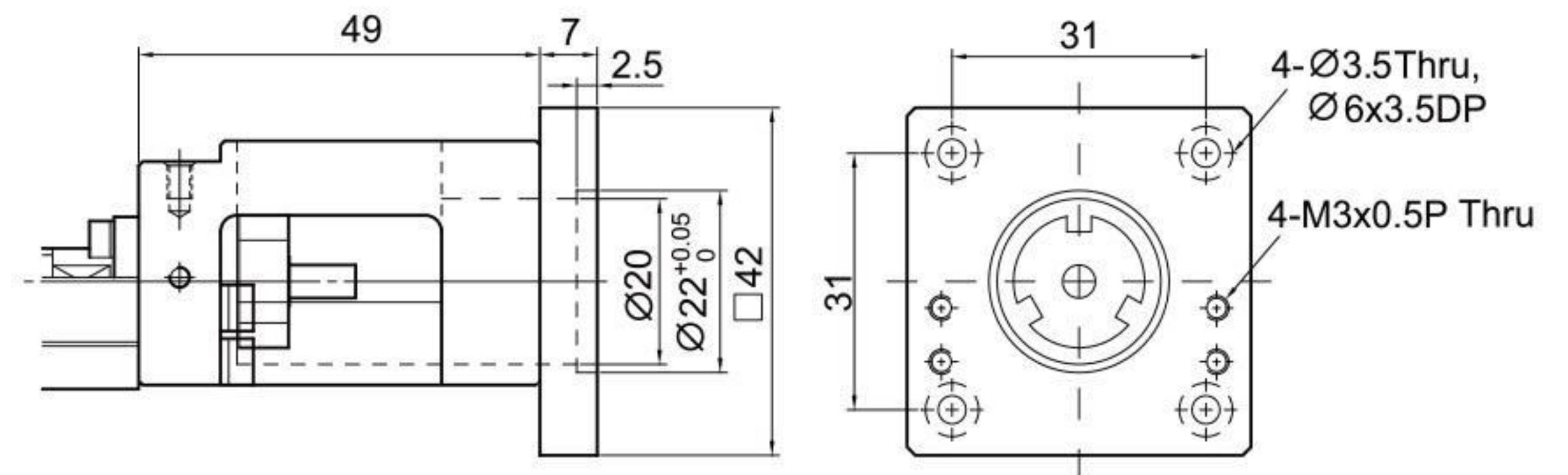

Motor Adaptor Flange F2

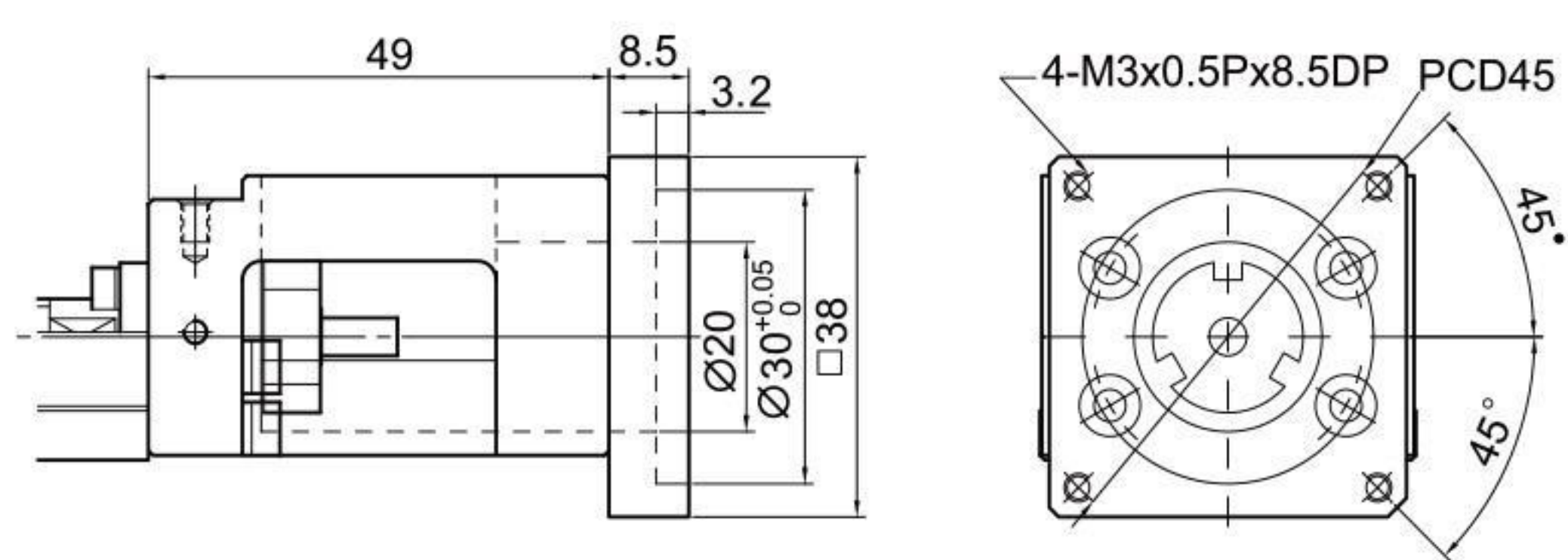

Motor Housing H0

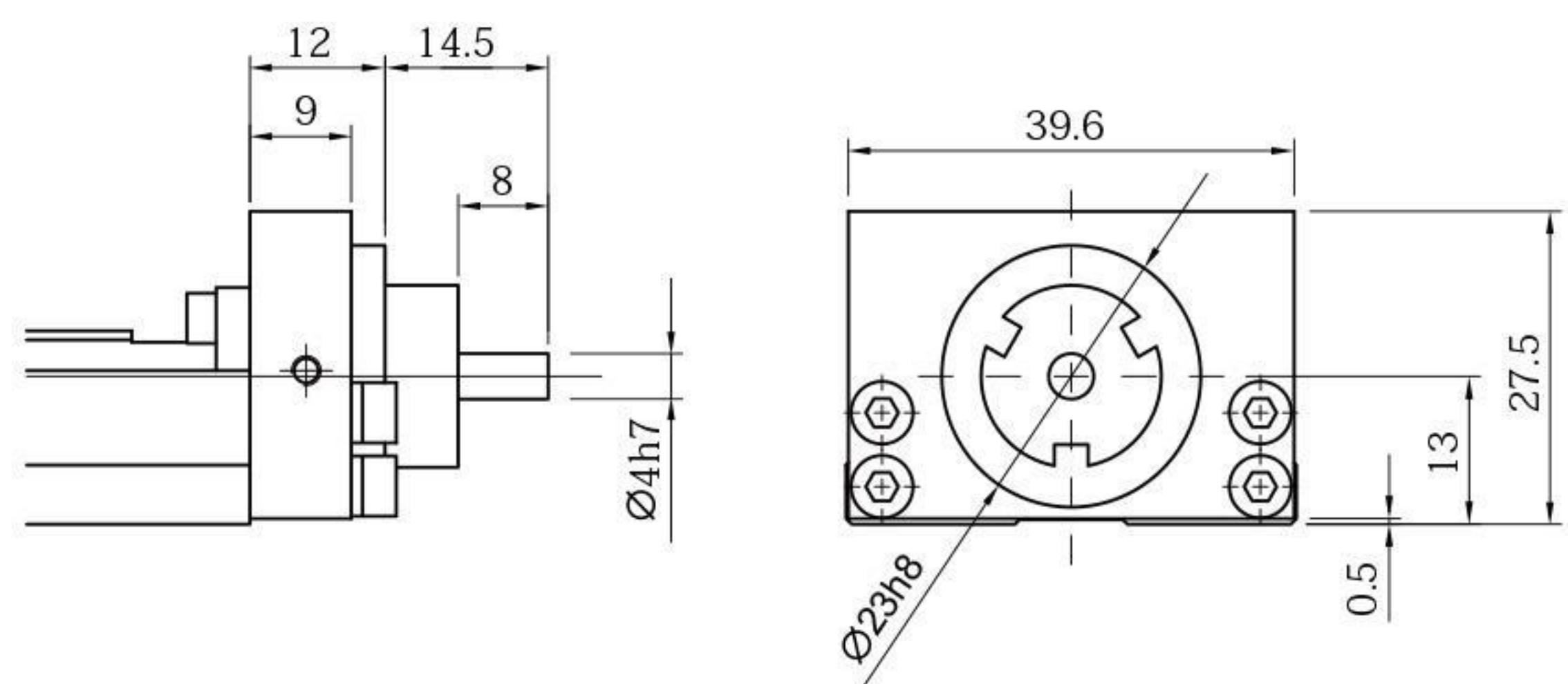

## KK50

Motor Housing F0

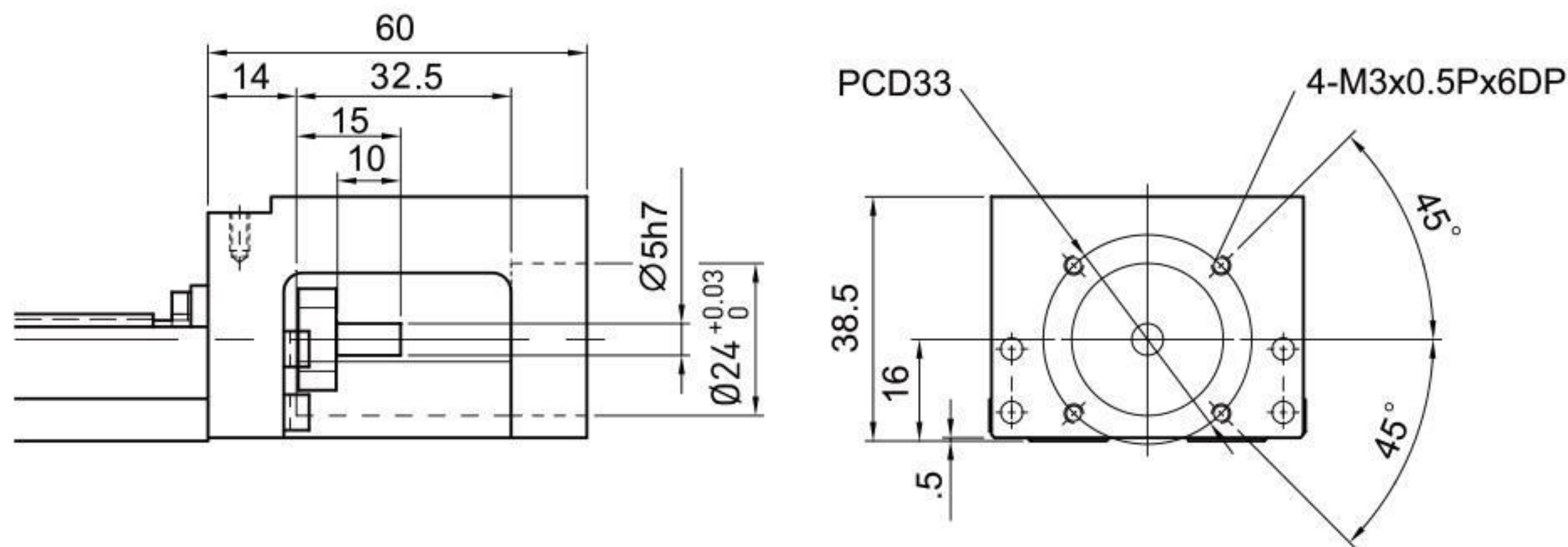

Motor Adaptor Flange F1

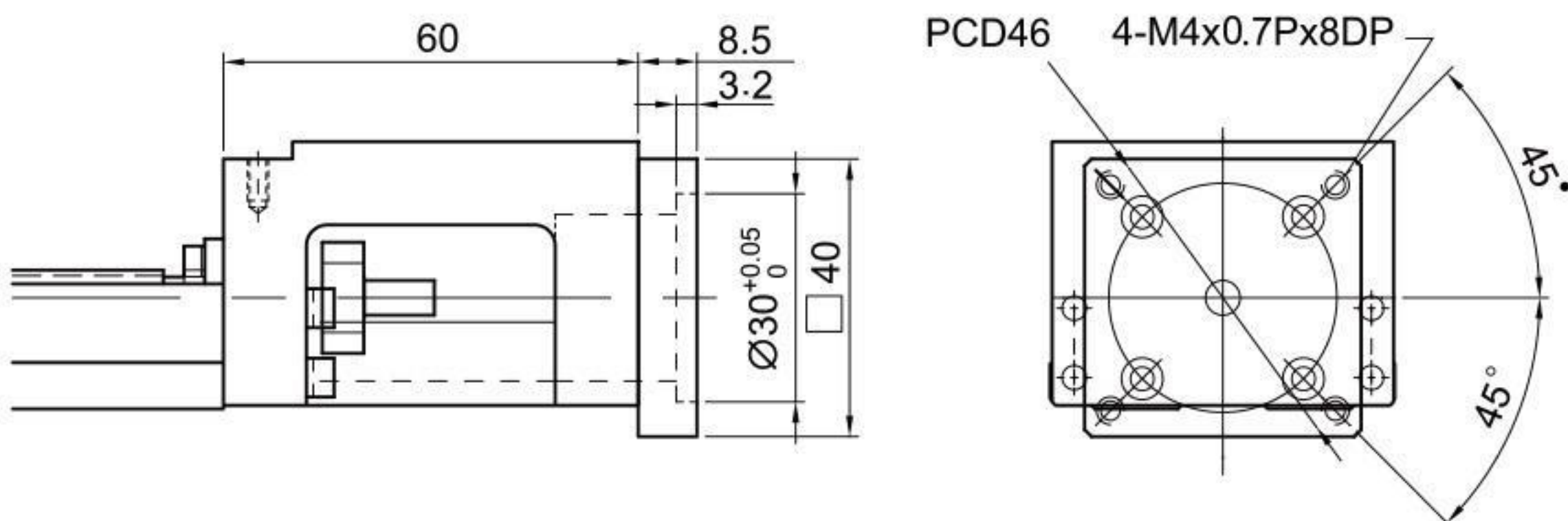

Motor Adaptor Flange F3

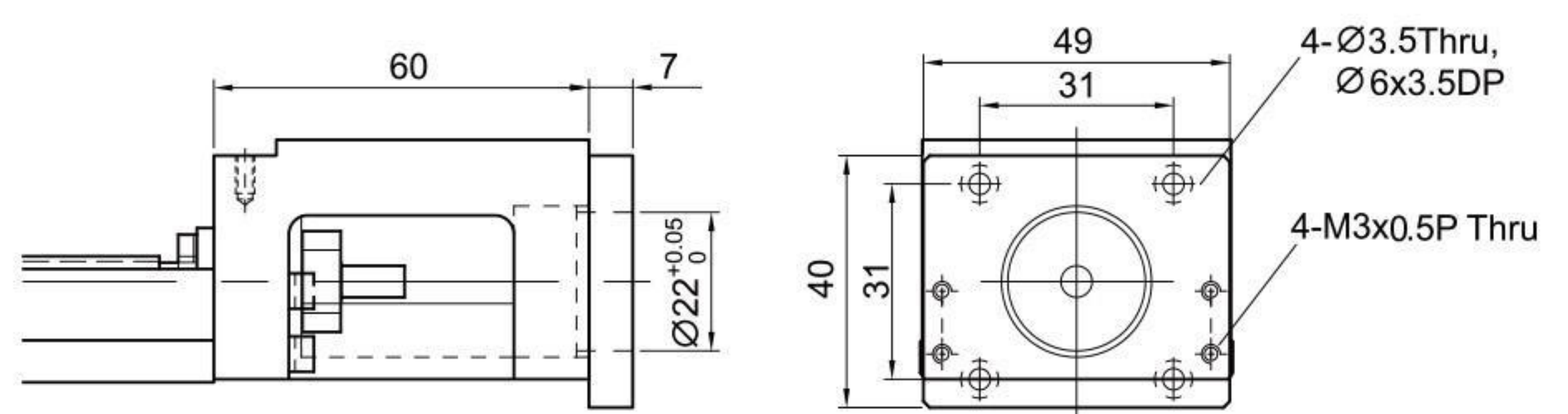

Motor Adaptor Flange F2

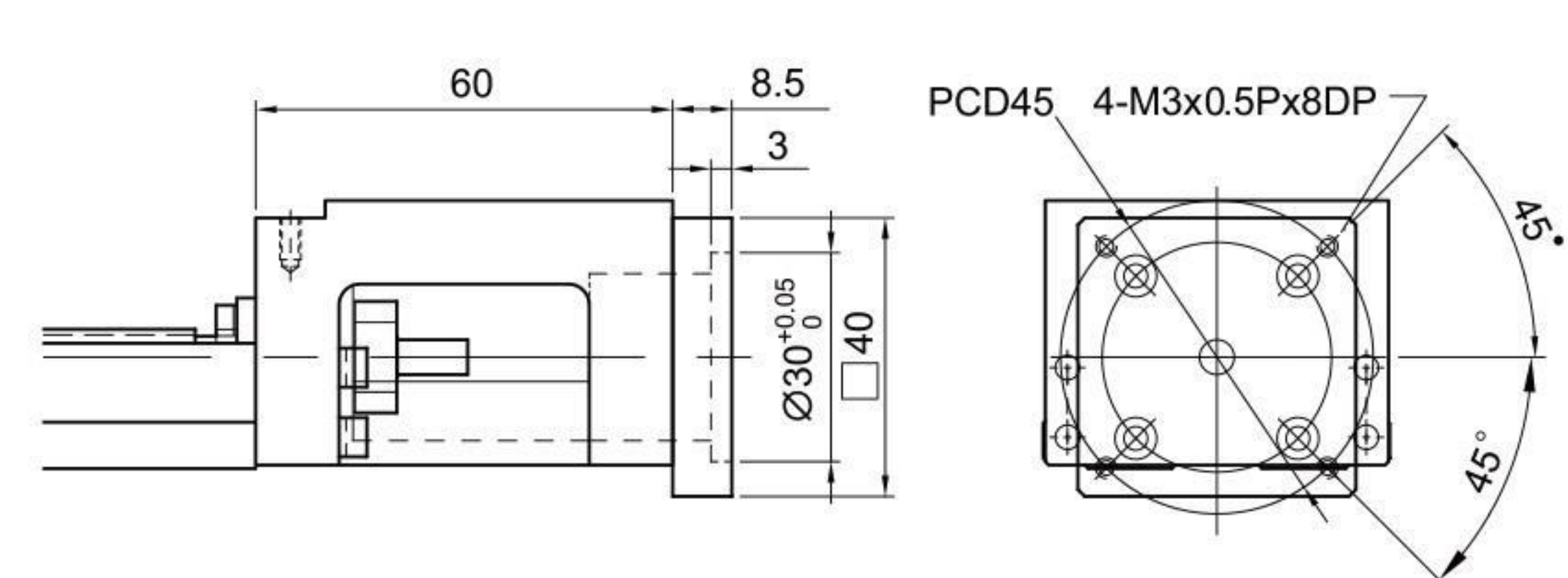

Motor Housing H0

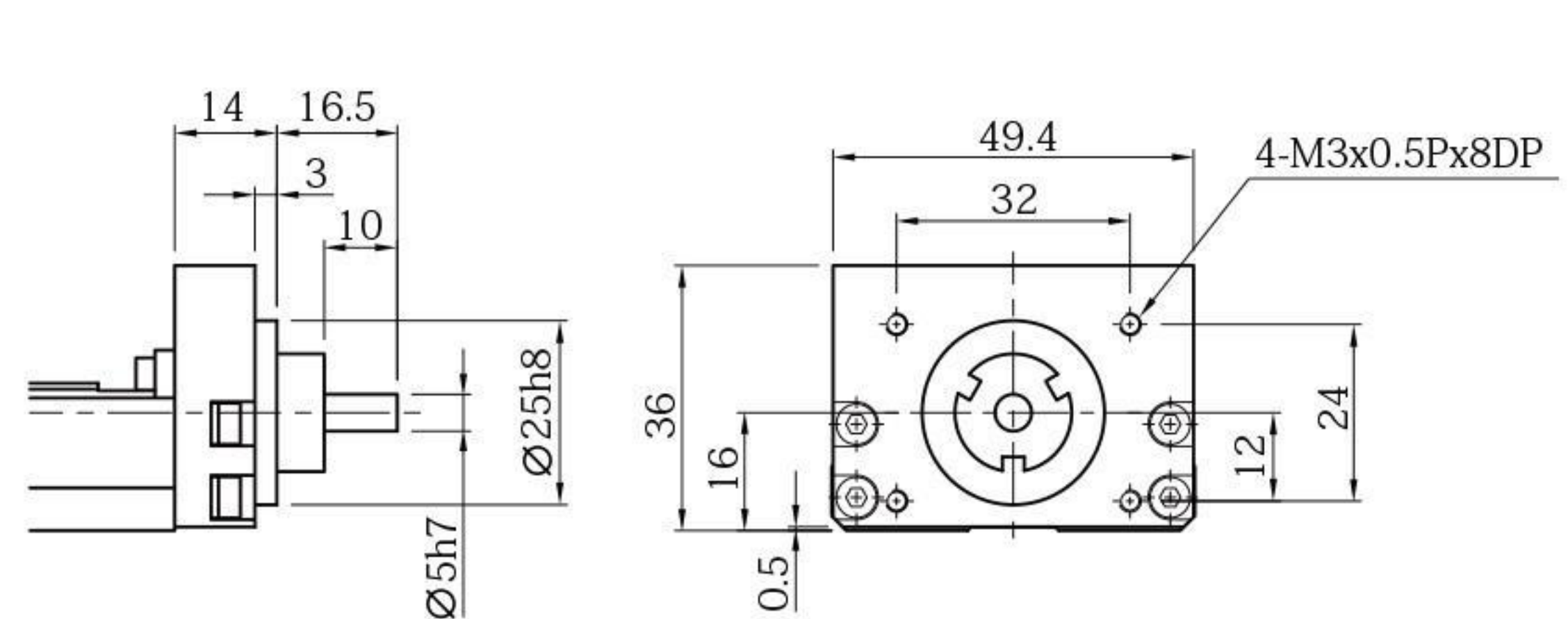



# Dimensions

## KK60 Motor Housing F0

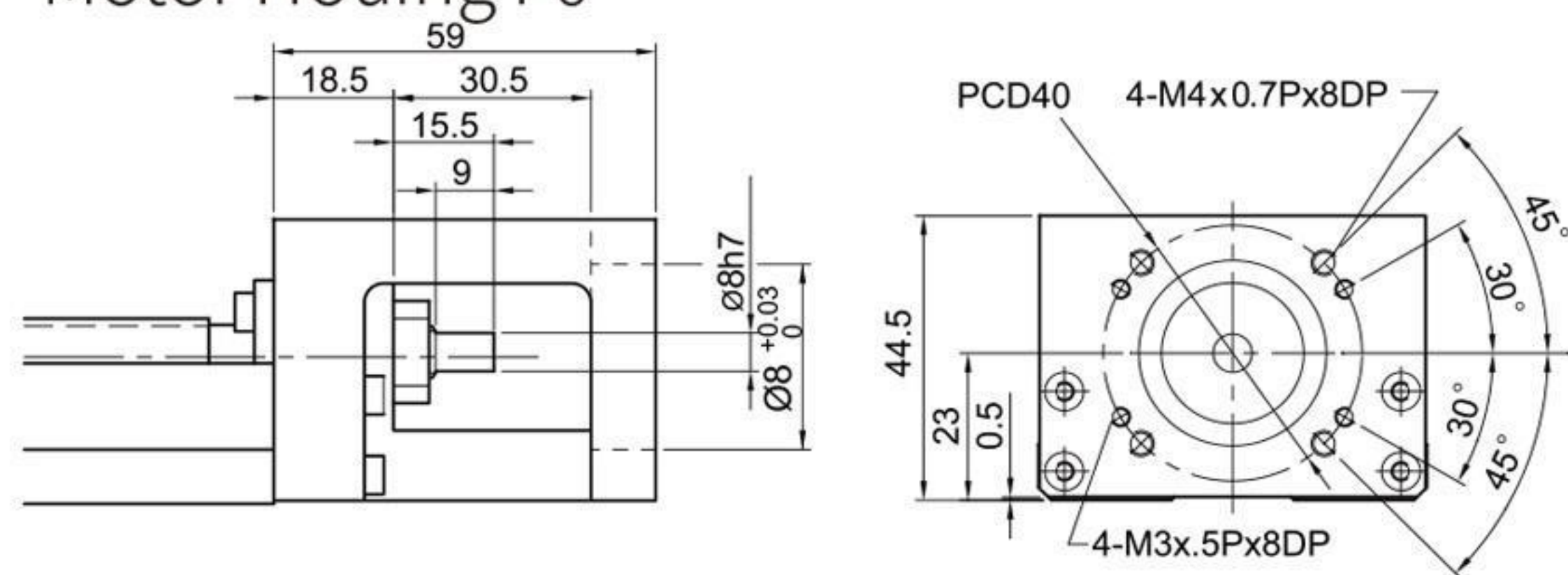

## Motor Adaptor Flange F3

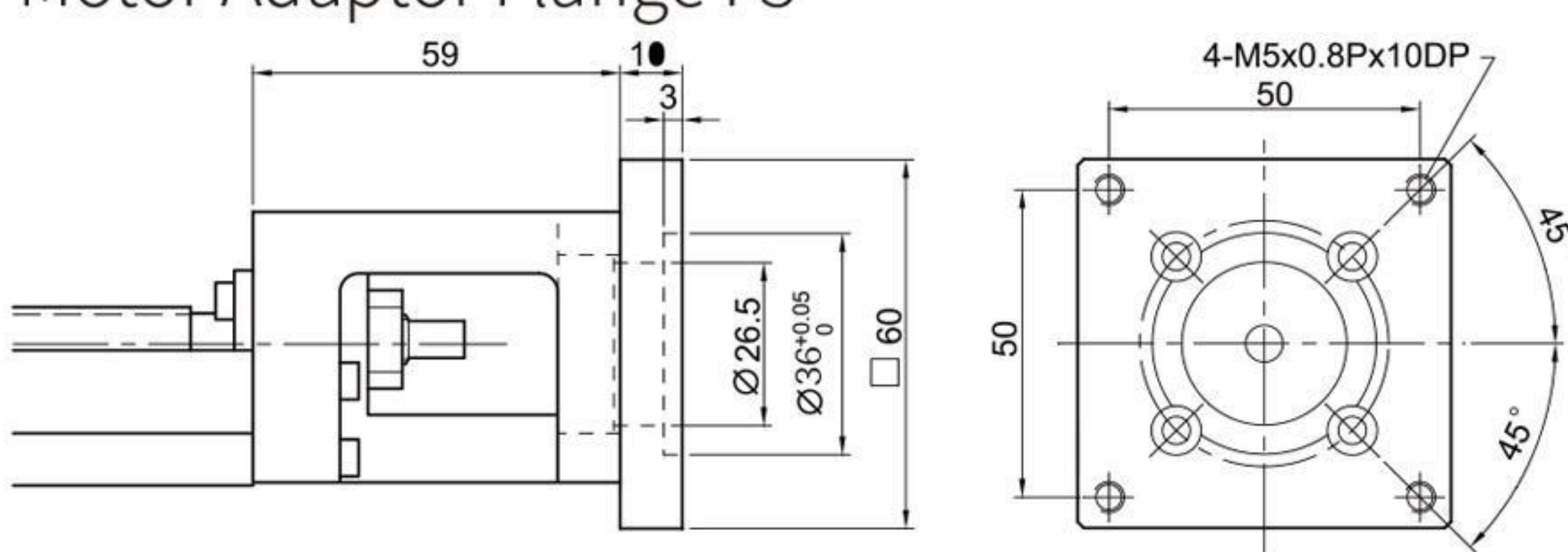

## Motor Adaptor Flange F1

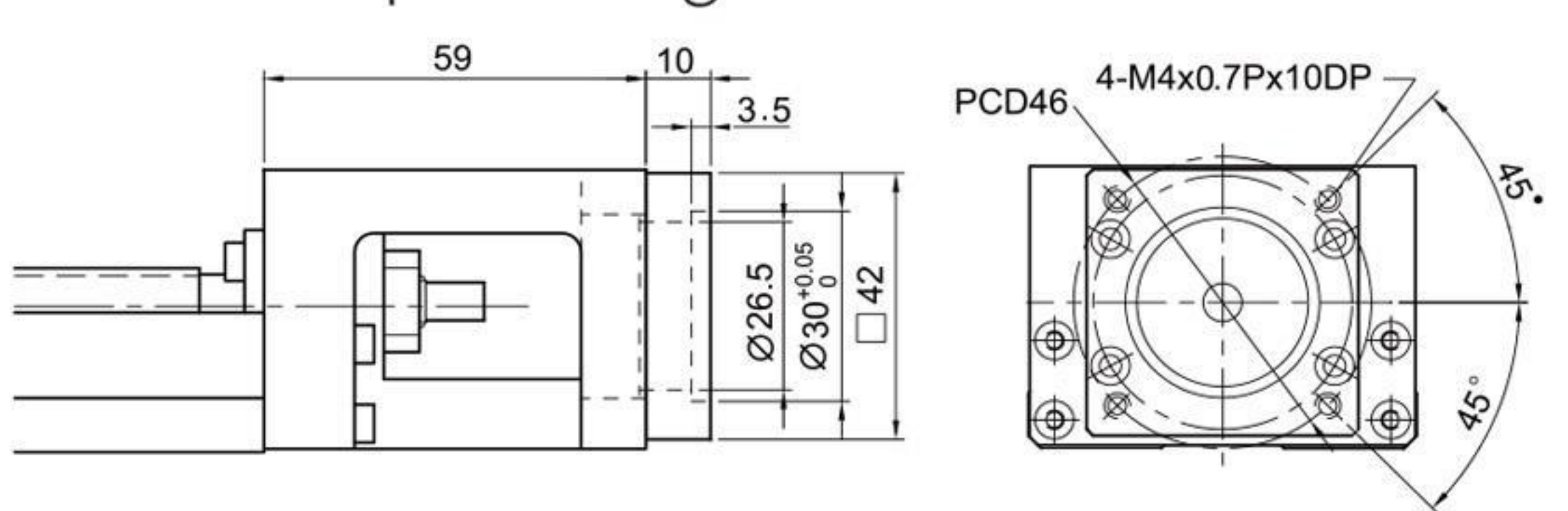

## Motor Adaptor Flange F4

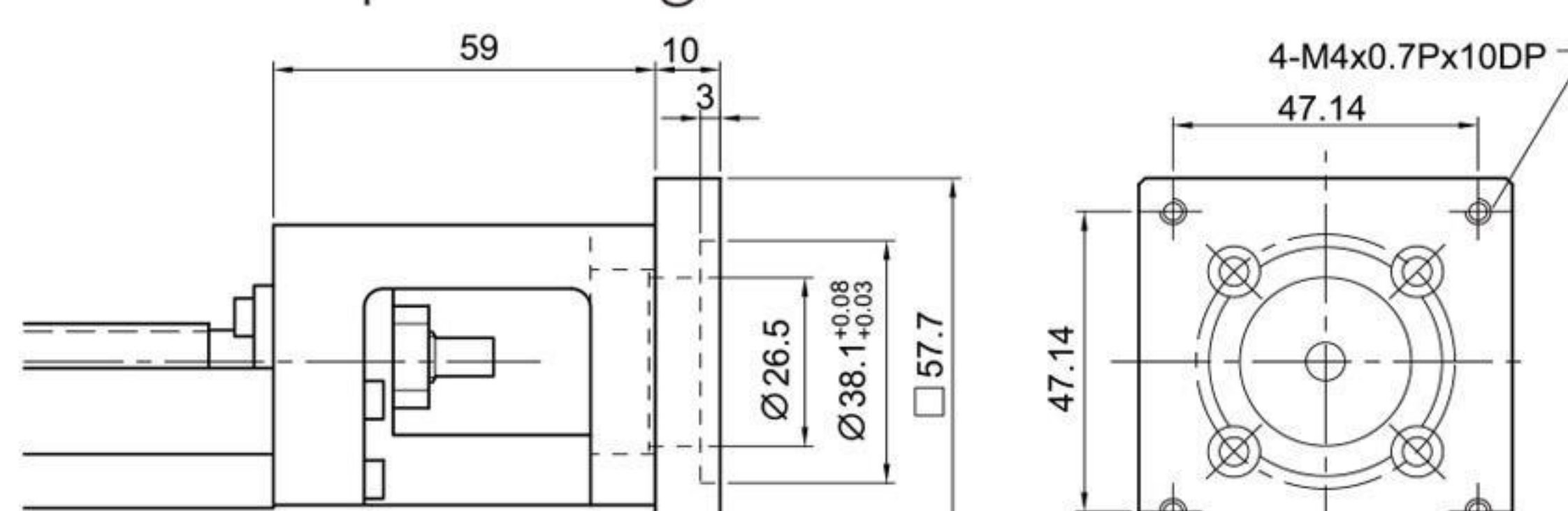

## Motor Adaptor Flange F2

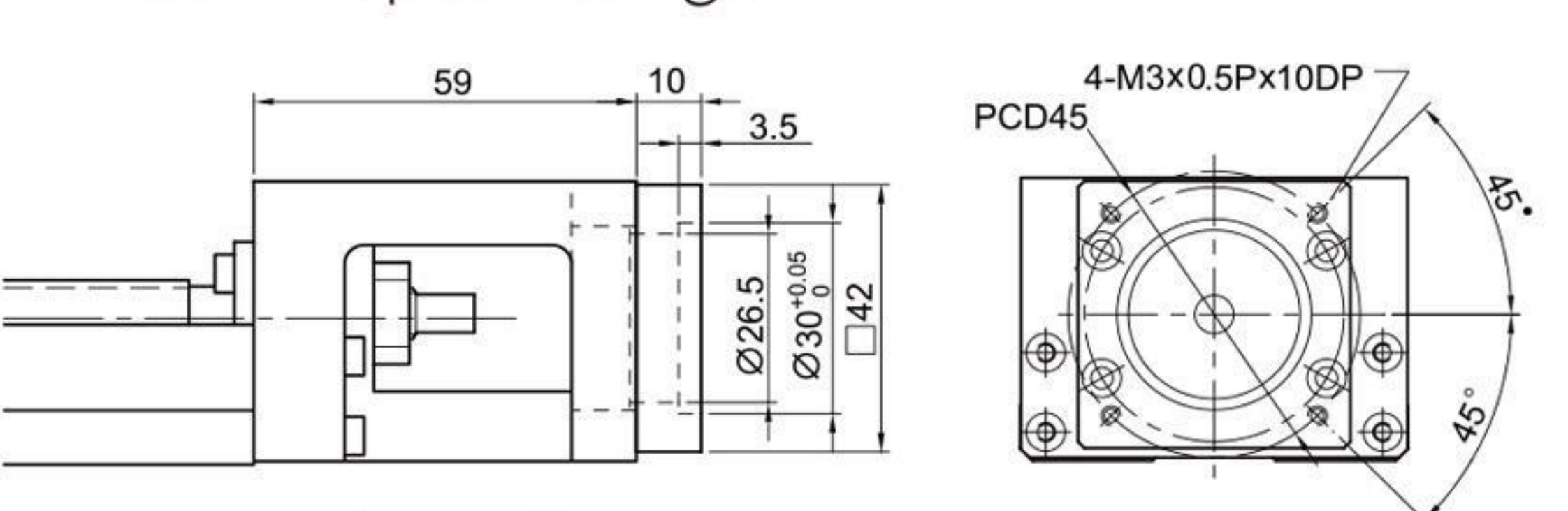

## Motor Adaptor Flange F5

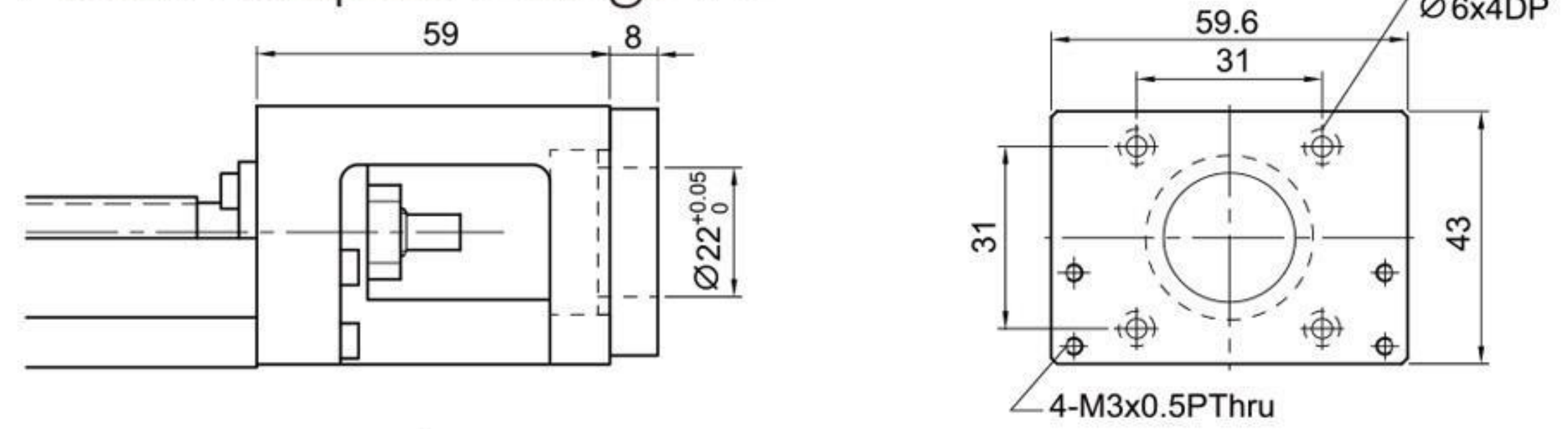

## Motor Housing H0

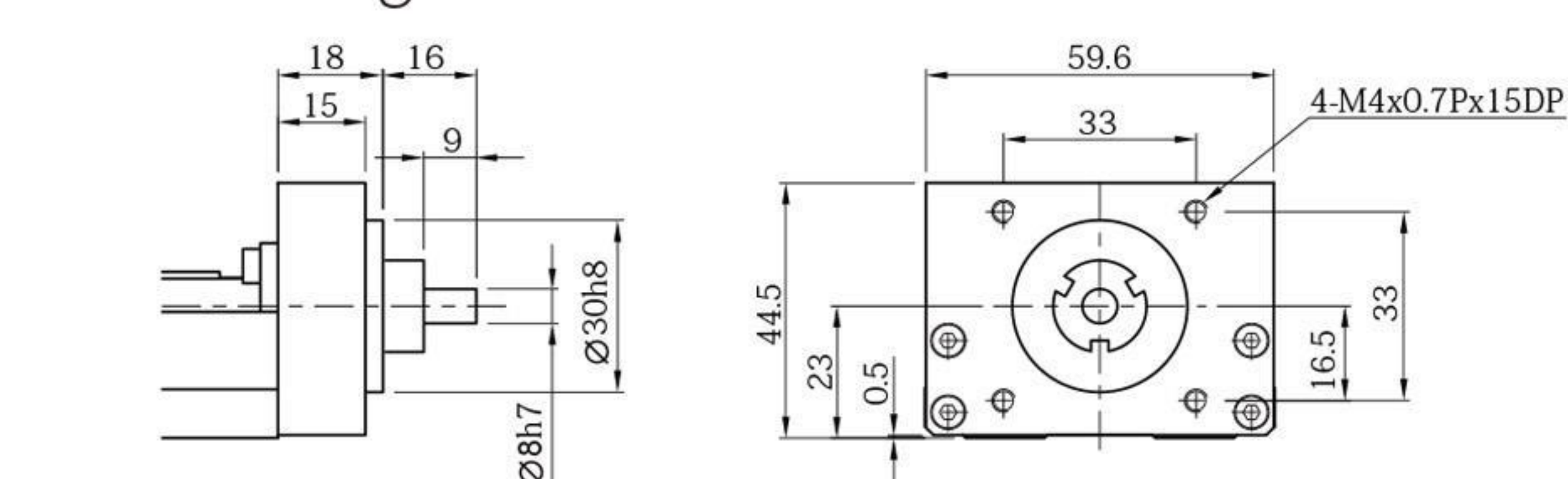

## Motor Housing H1

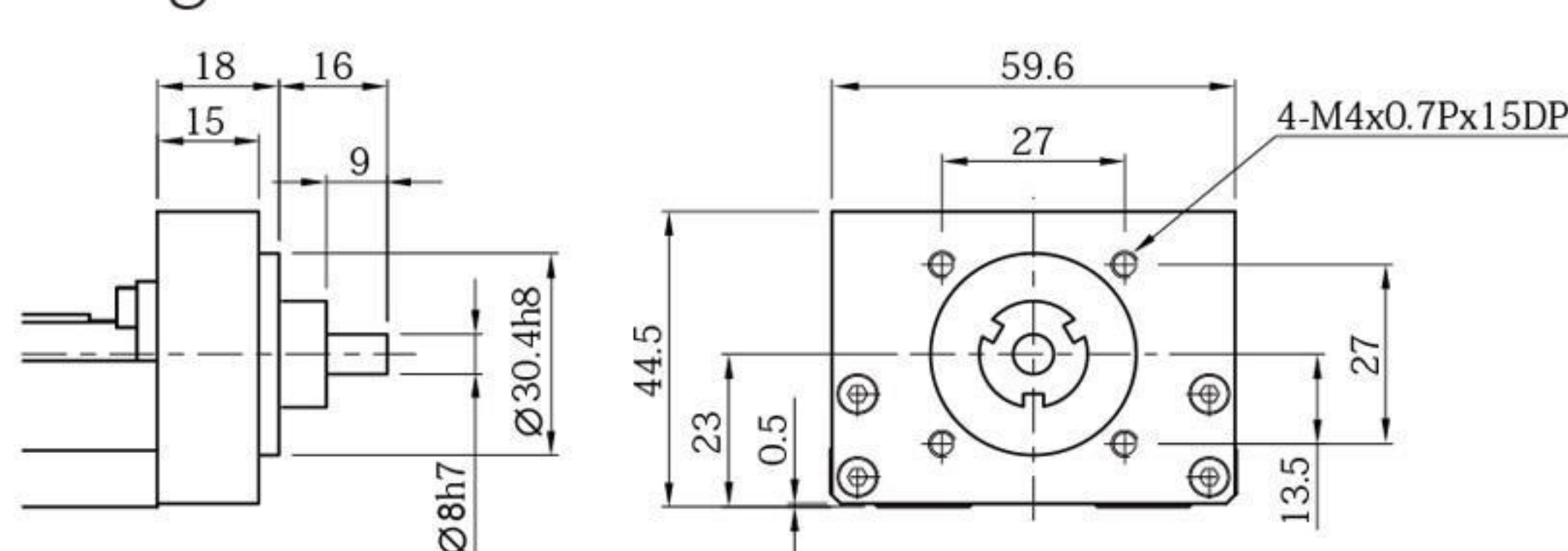

## KK86

### Motor Housing H0

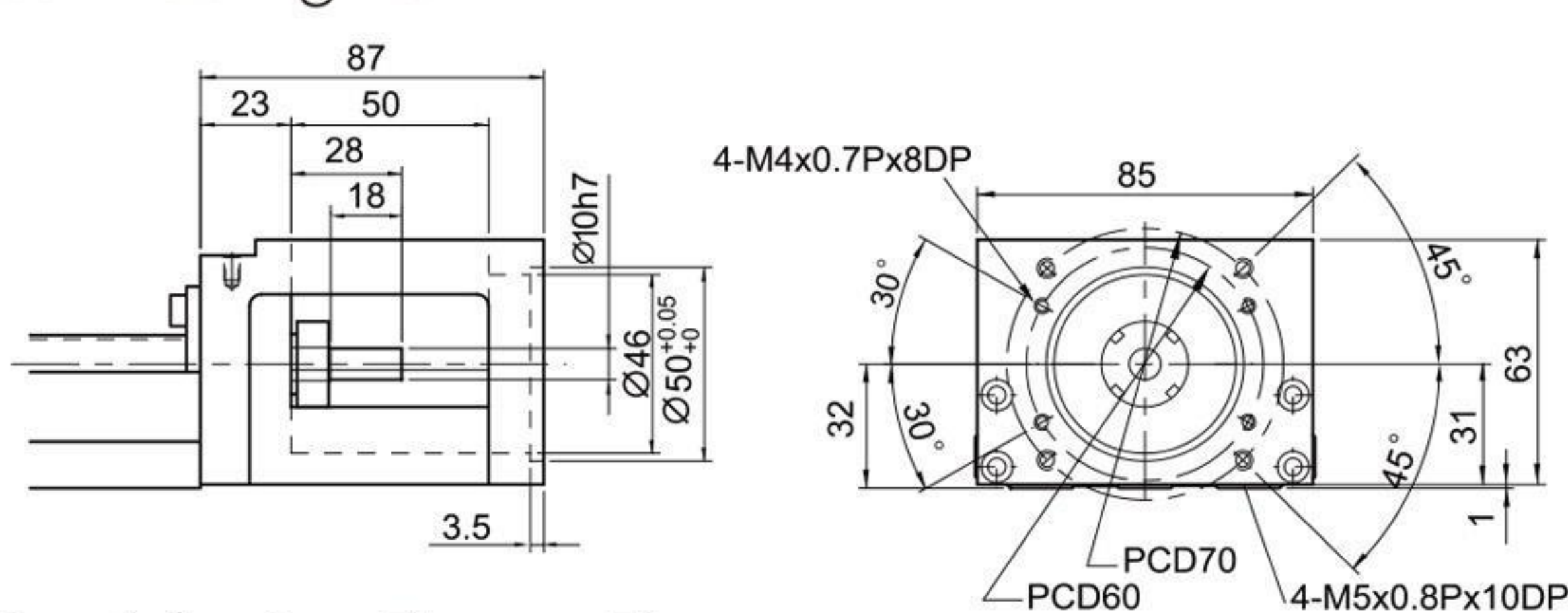

### Motor Adaptor Flange F4

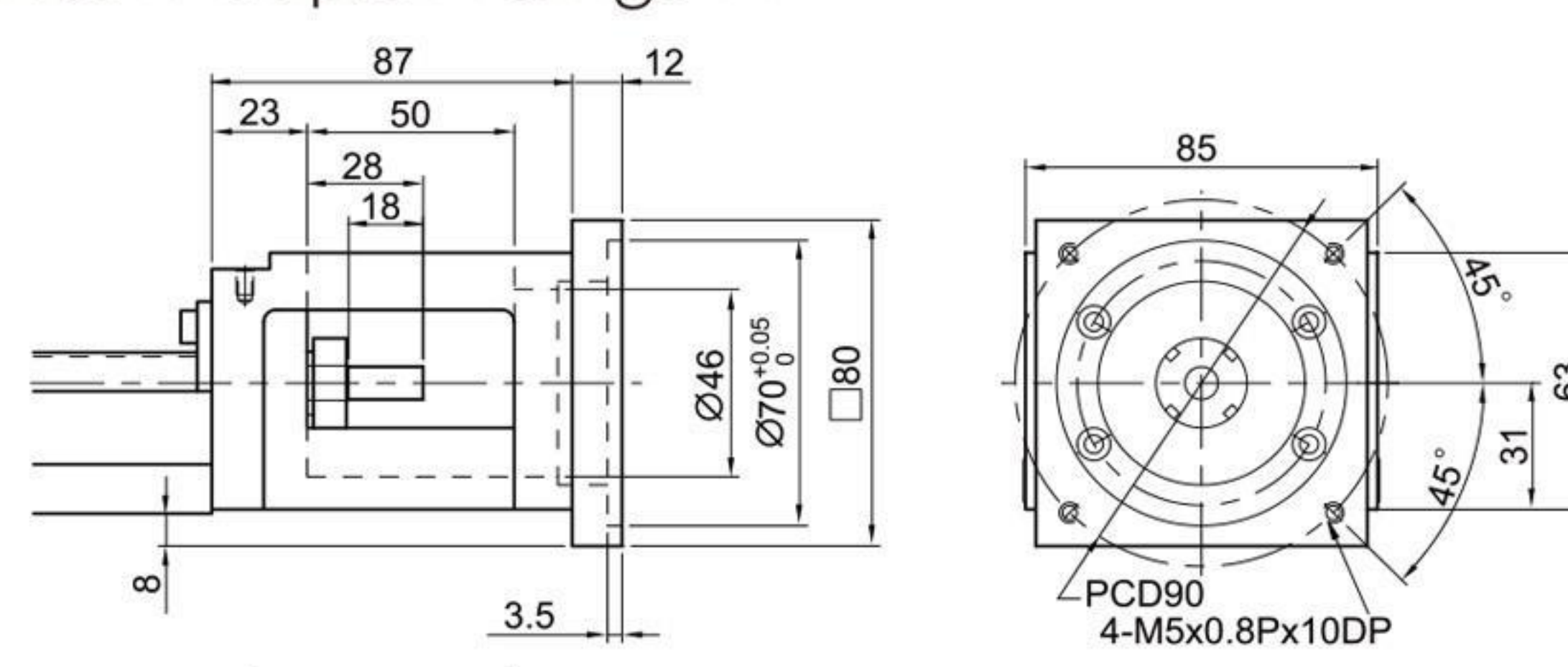

### Motor Adaptor Flange F1

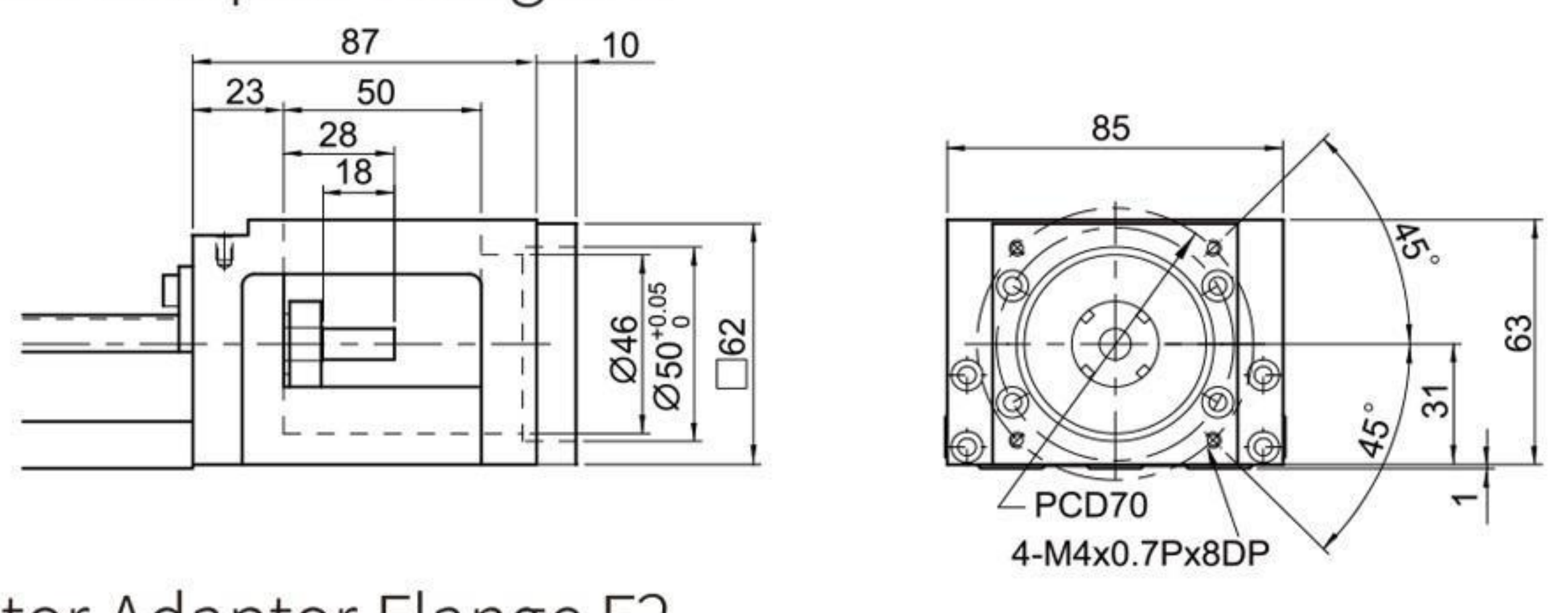

### Motor Adaptor Flange F5

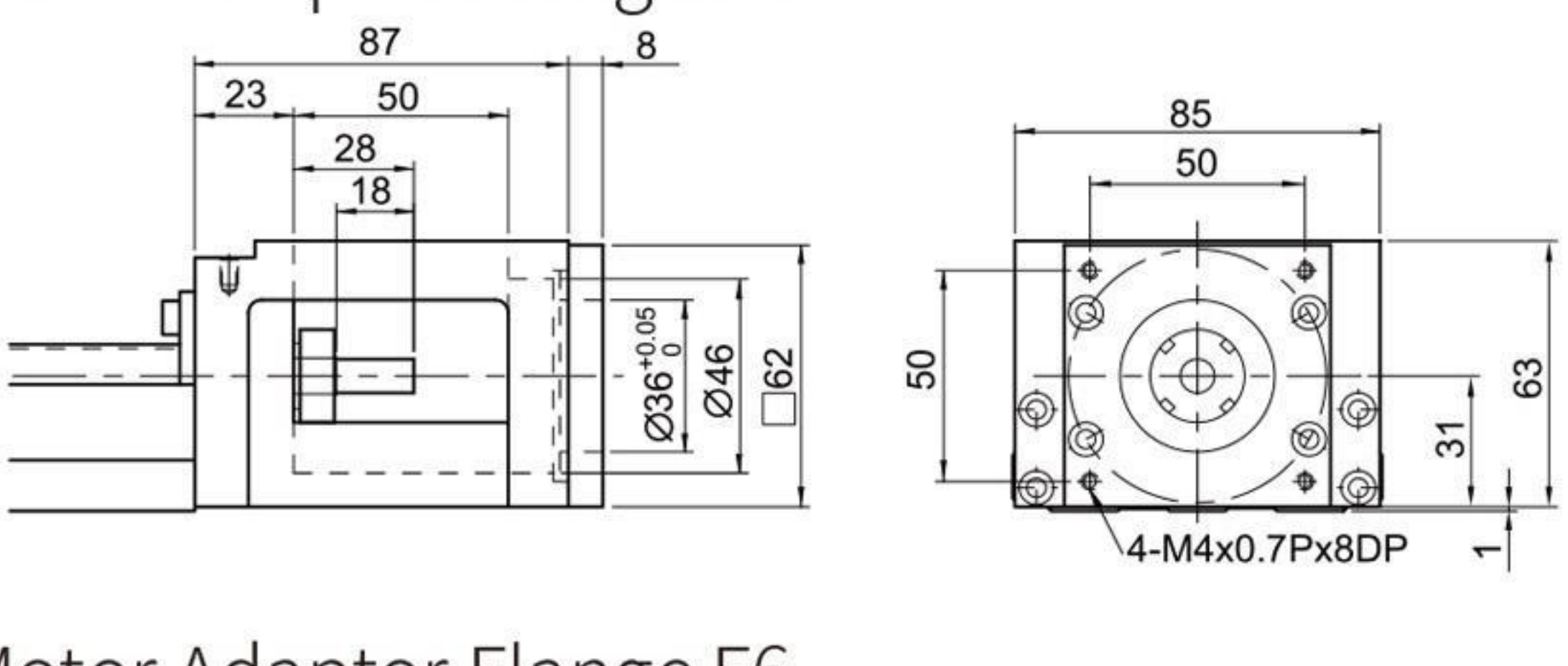

### Motor Adaptor Flange F2

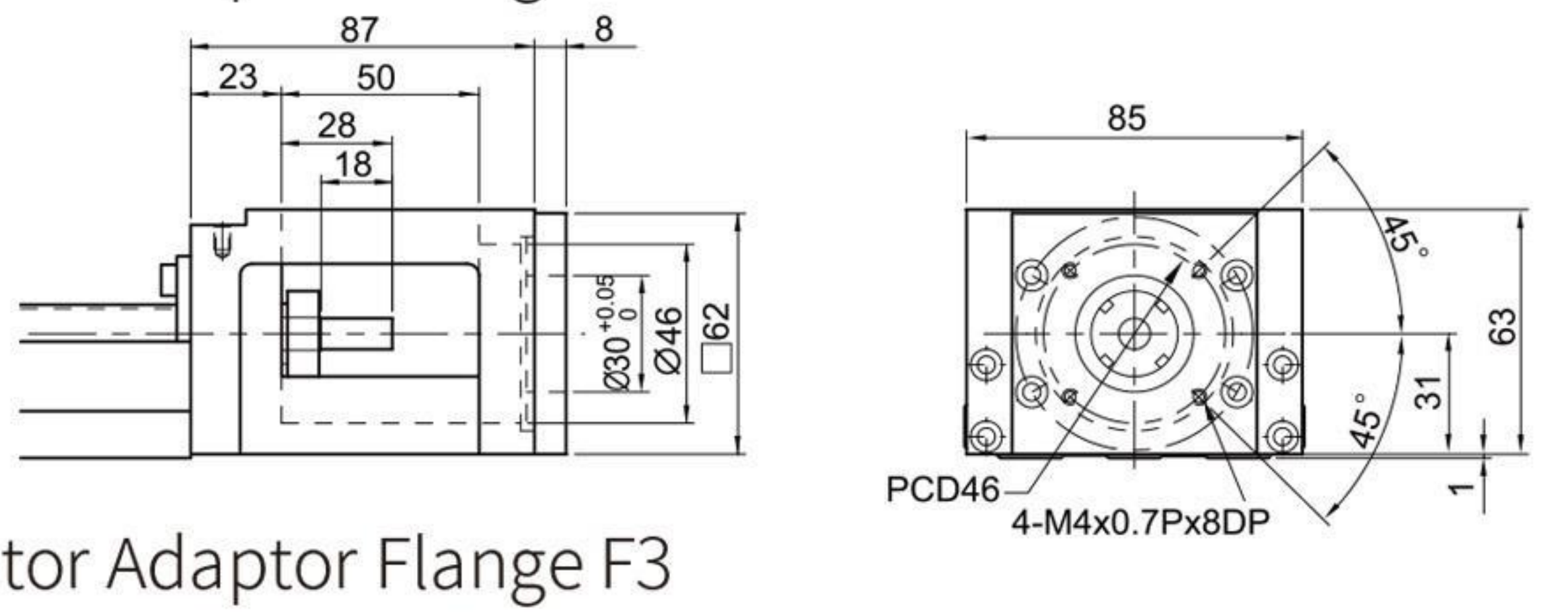

### Motor Adaptor Flange F6

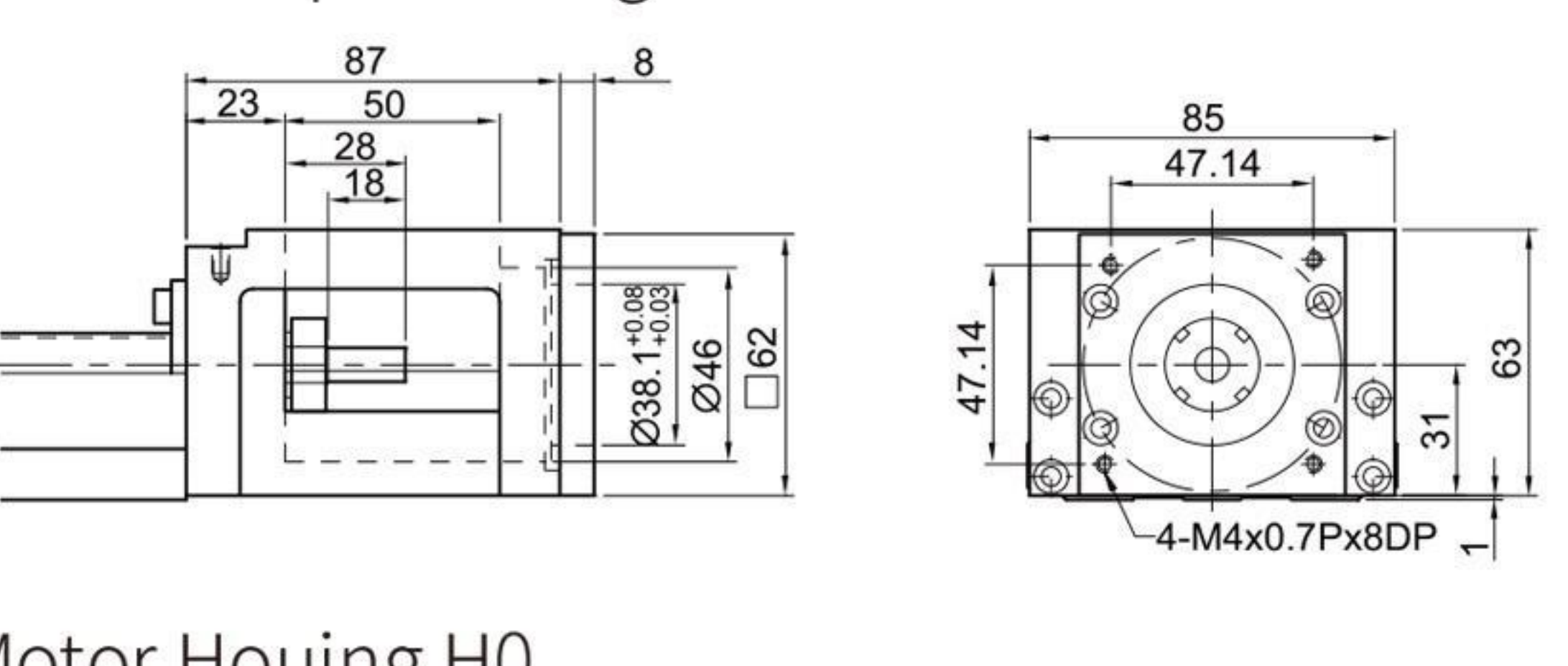

### Motor Adaptor Flange F3

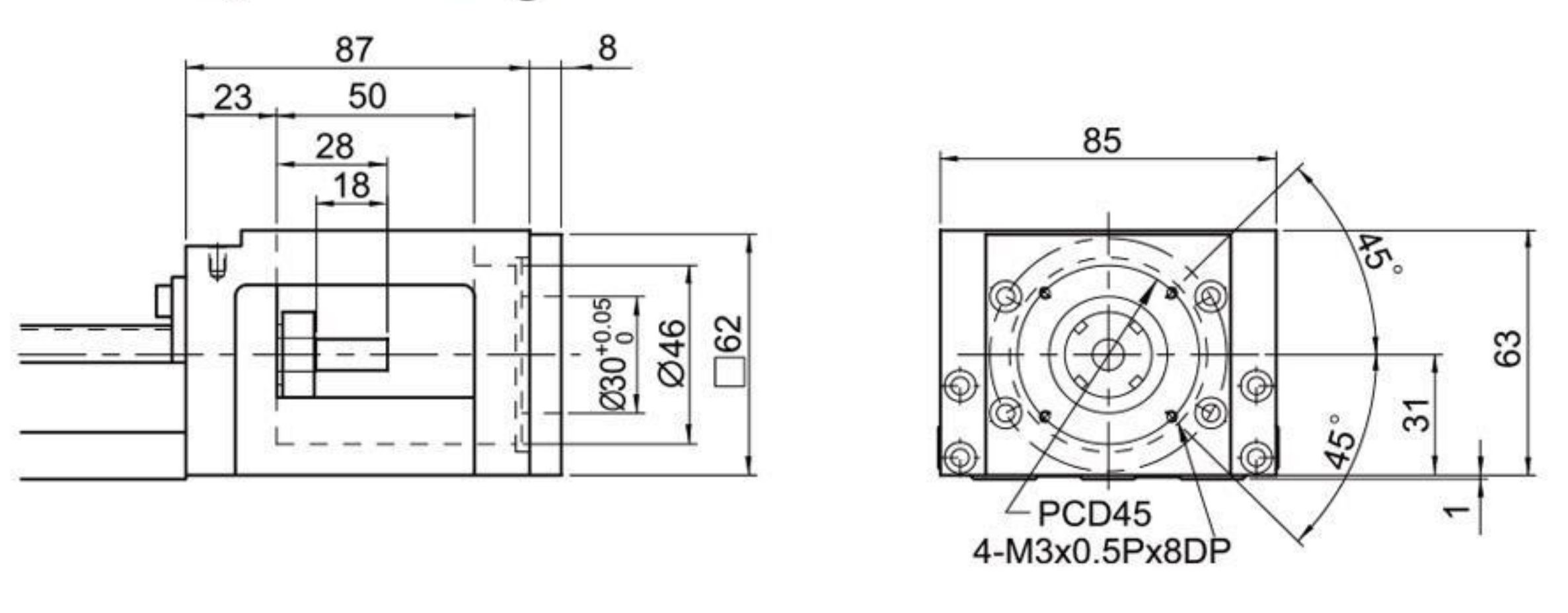

### Motor Housing H0

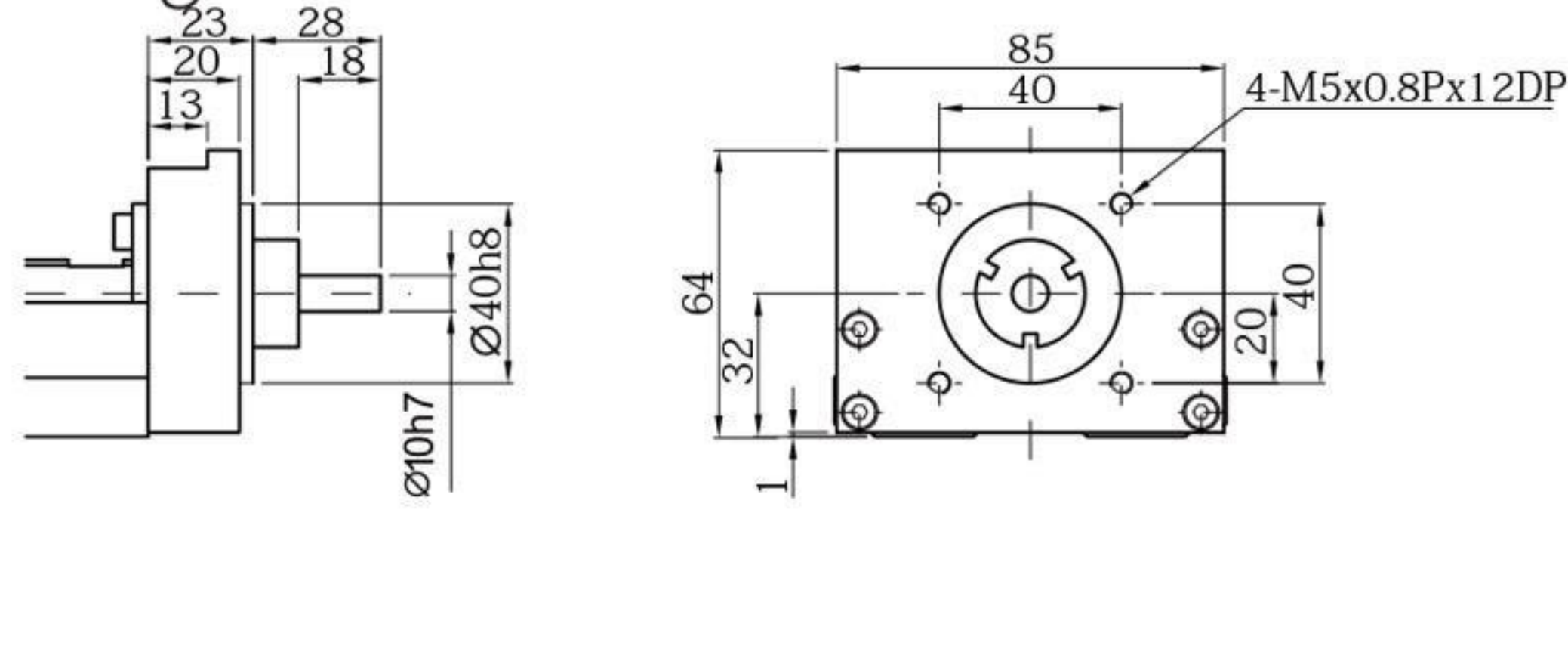



# Dimensions

## KK100

Motor Housing F0

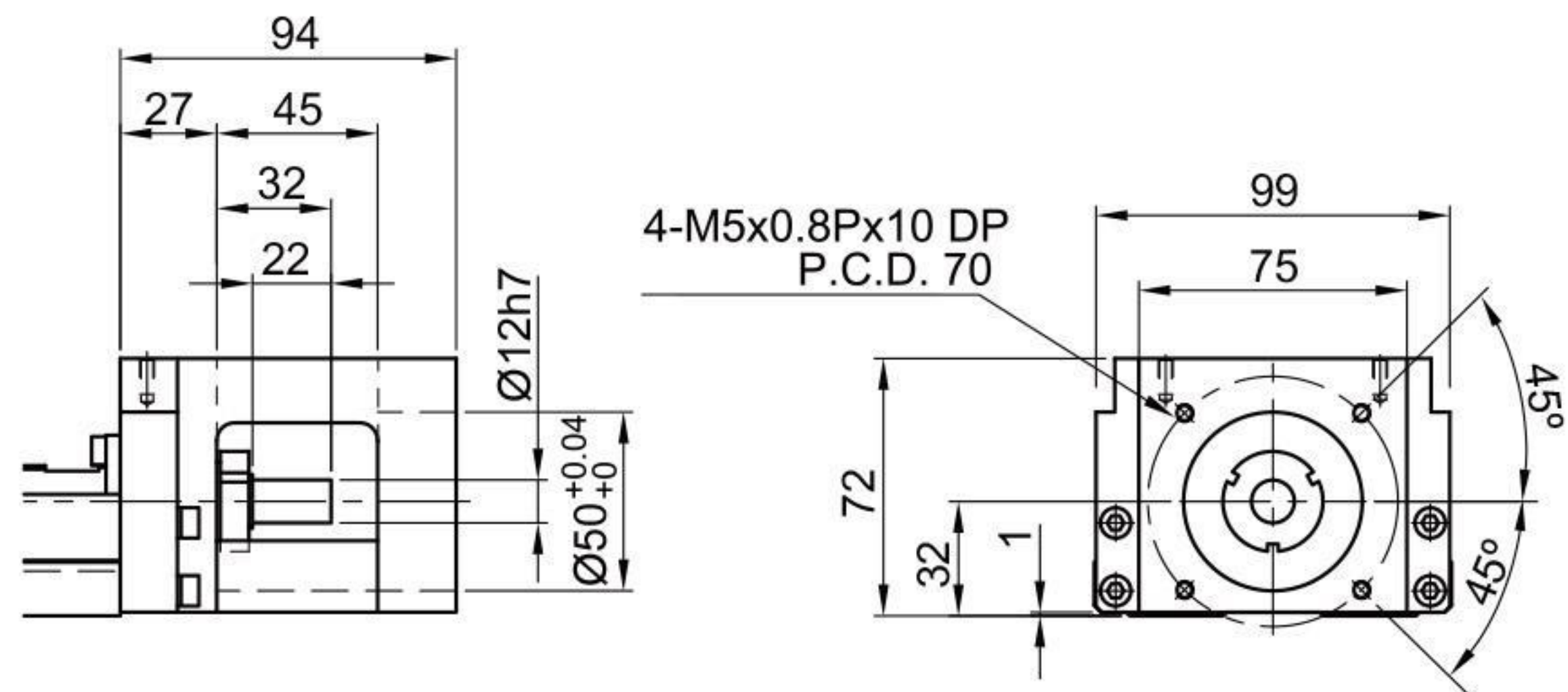

Motor Adaptor Flange F3

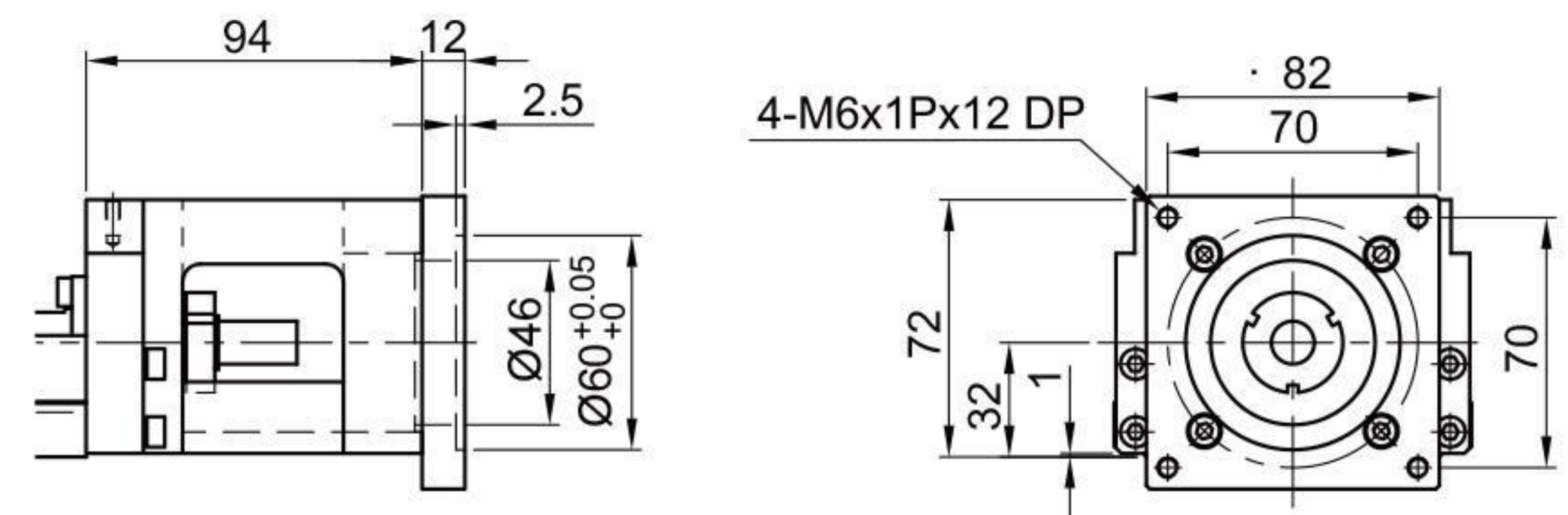

Motor Adaptor Flange F1

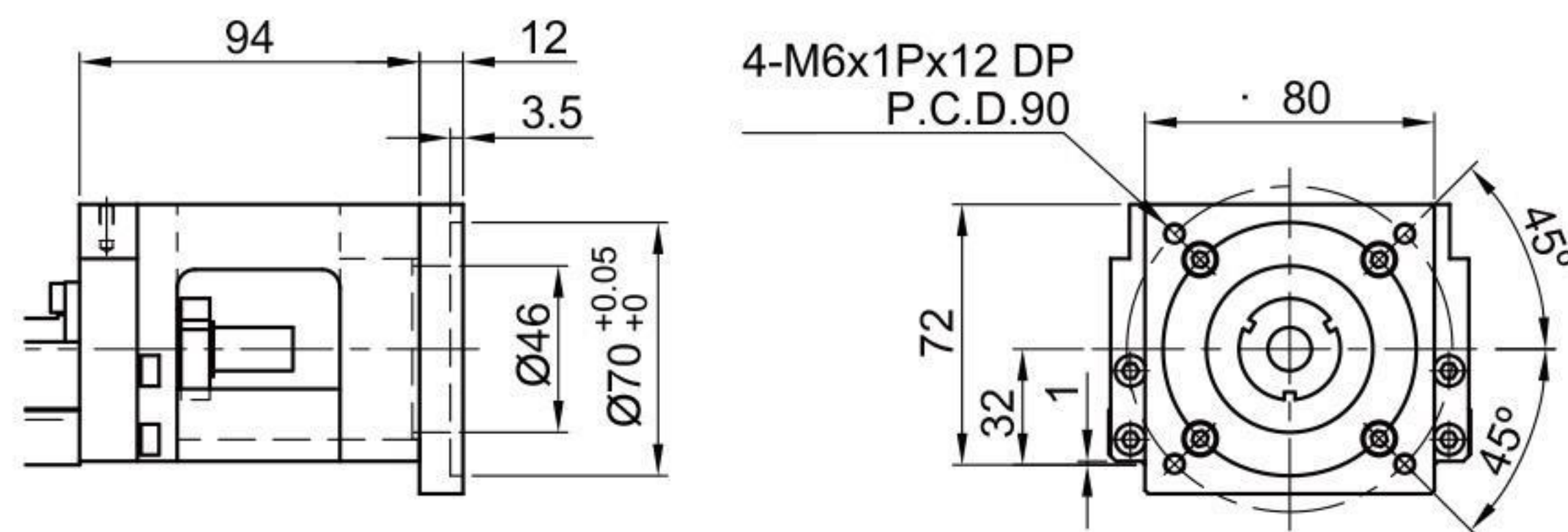

Motor Adaptor Flange F4

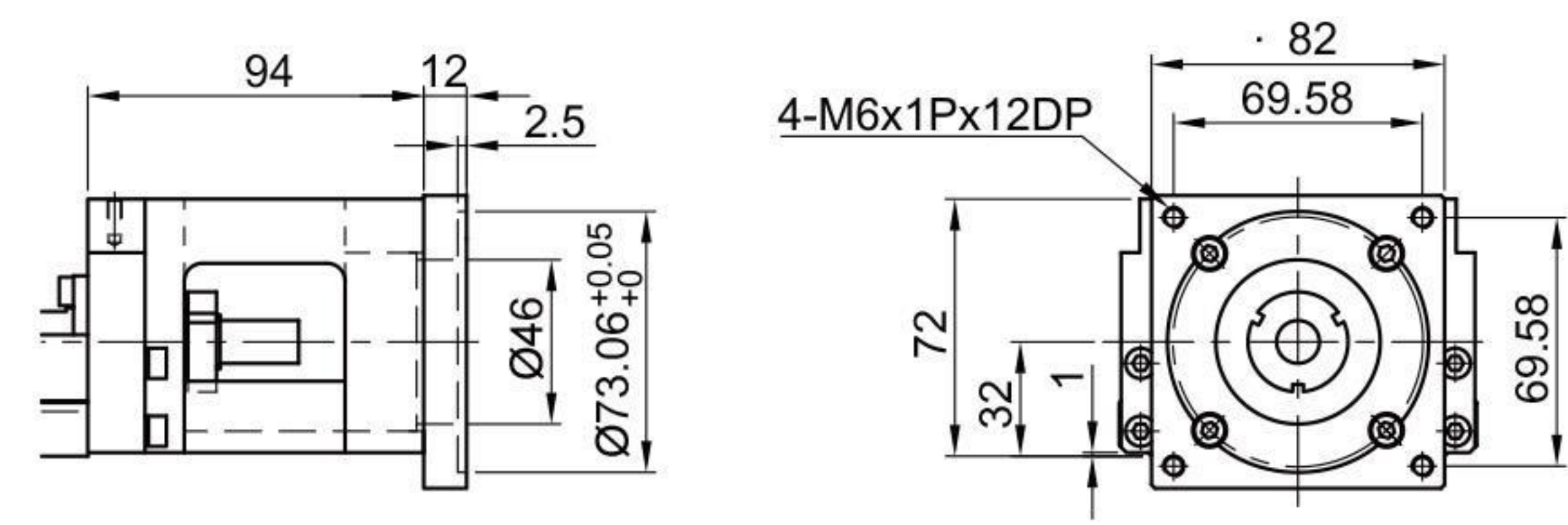

Motor Adaptor Flange F2

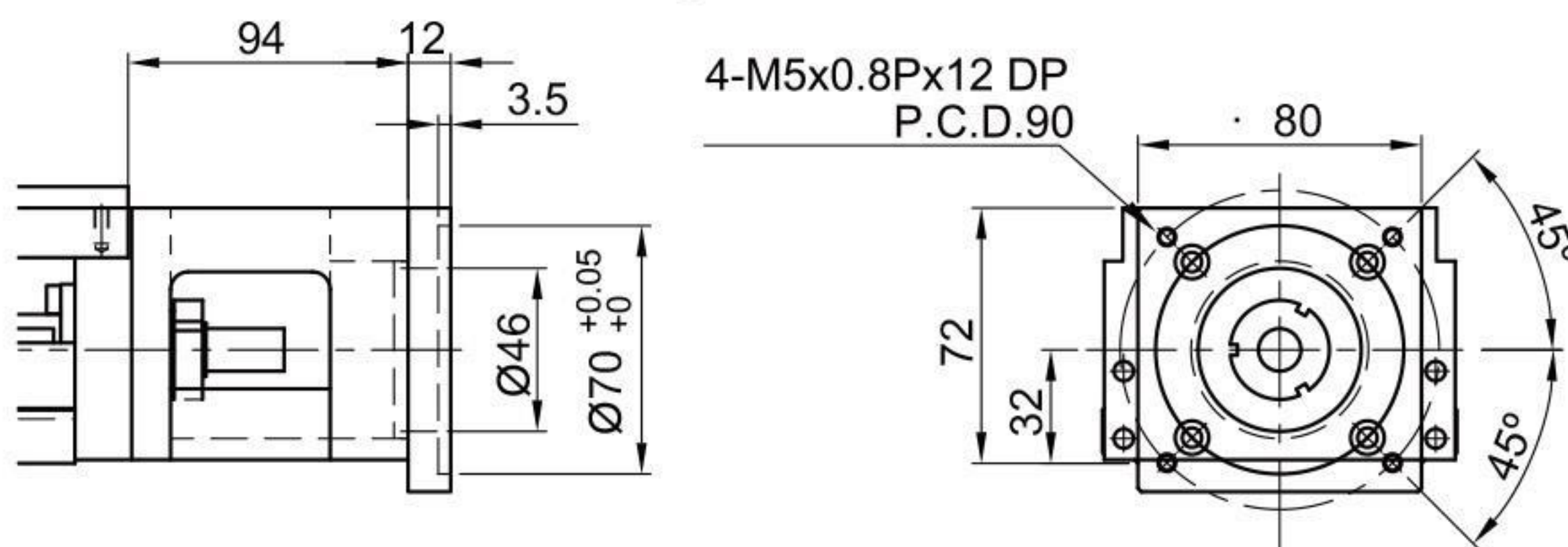

Motor Housing H0

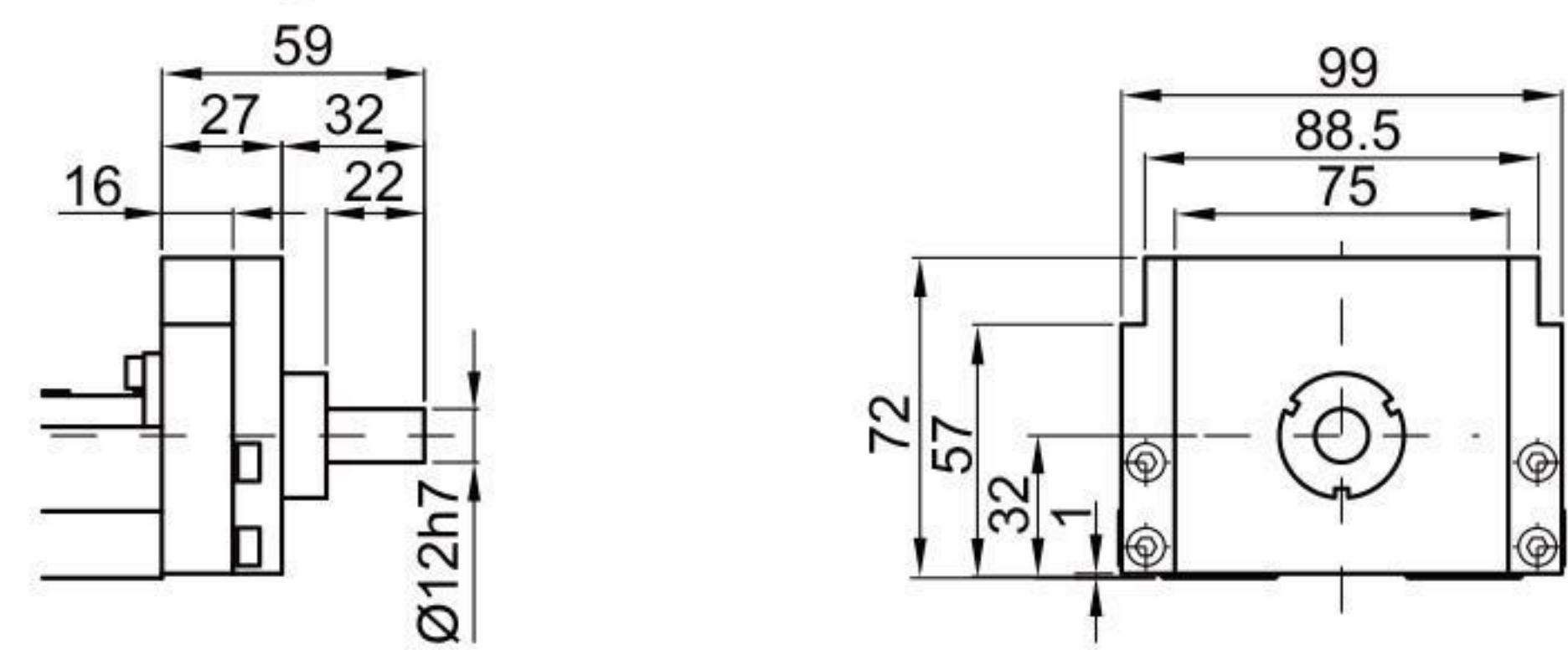

## KK130

Motor Housing F0

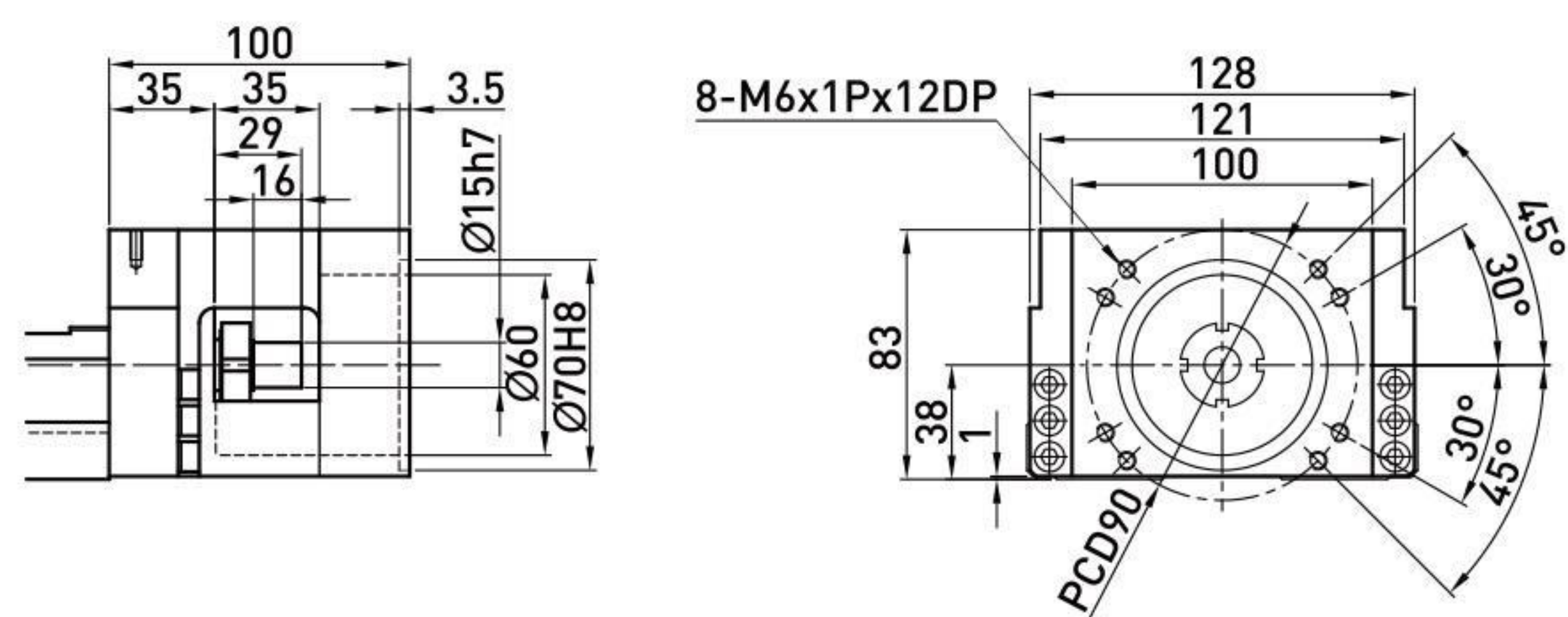

Motor Adaptor Flange F3

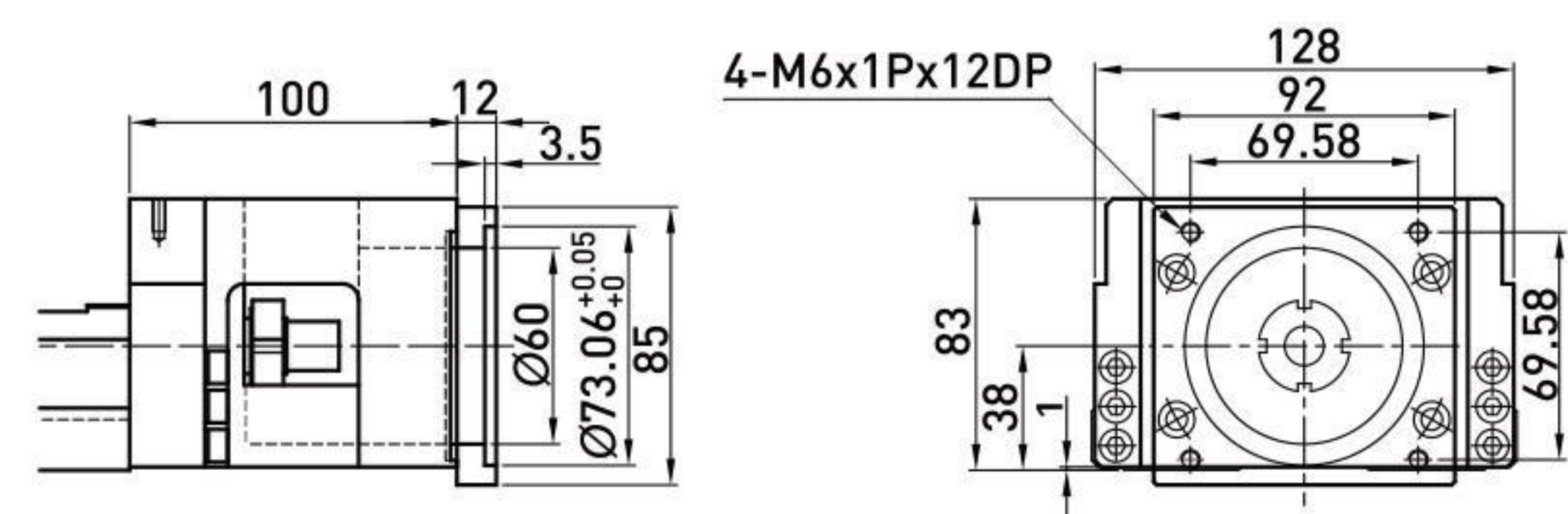

Motor Adaptor Flange F1

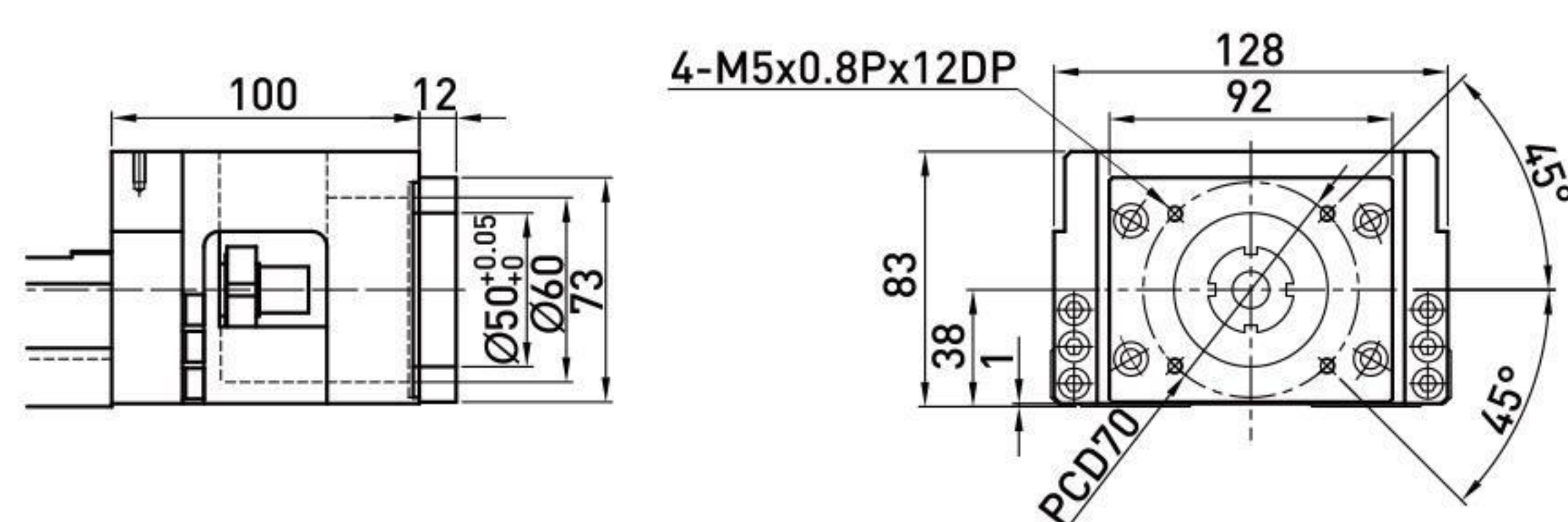

Motor Adaptor Flange F4

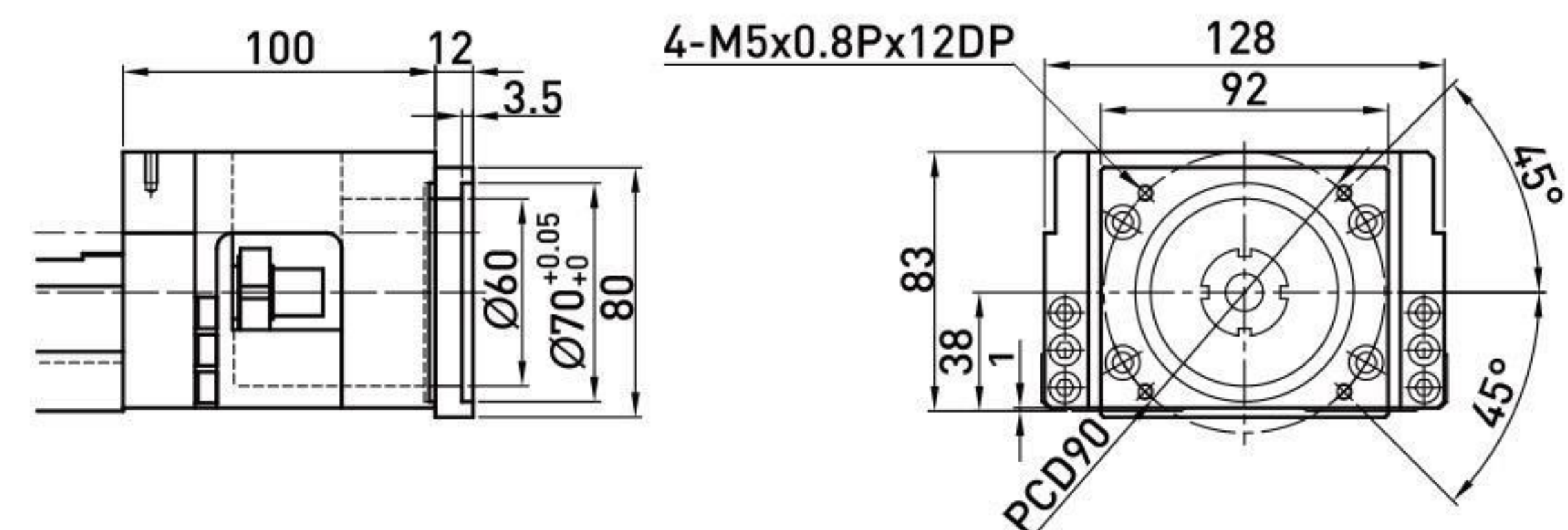

Motor Adaptor Flange F2

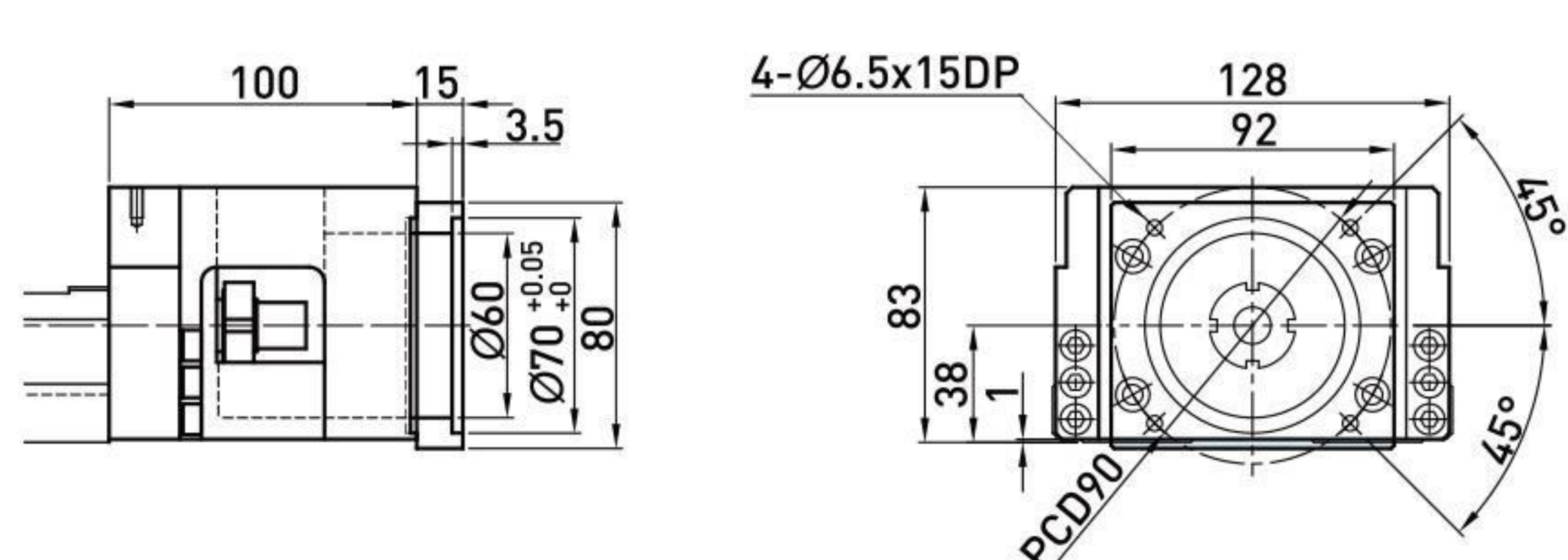

Motor Housing H0

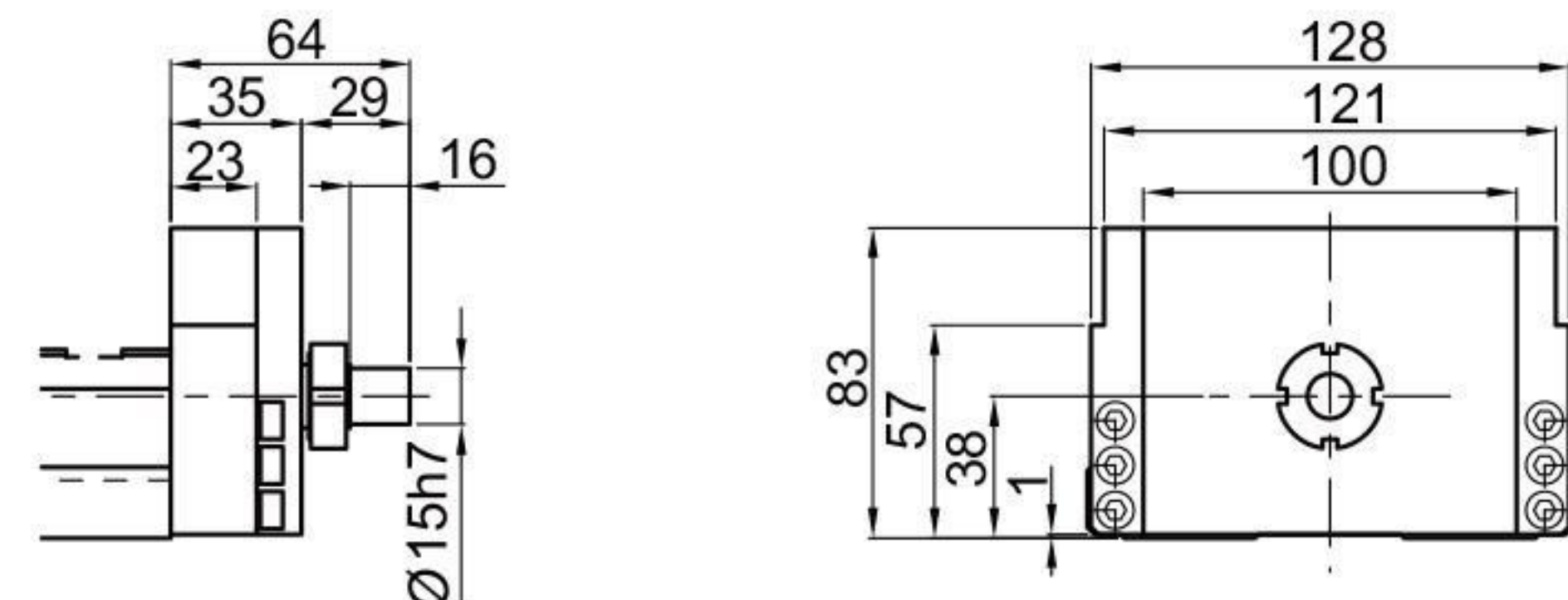



## Dimensions

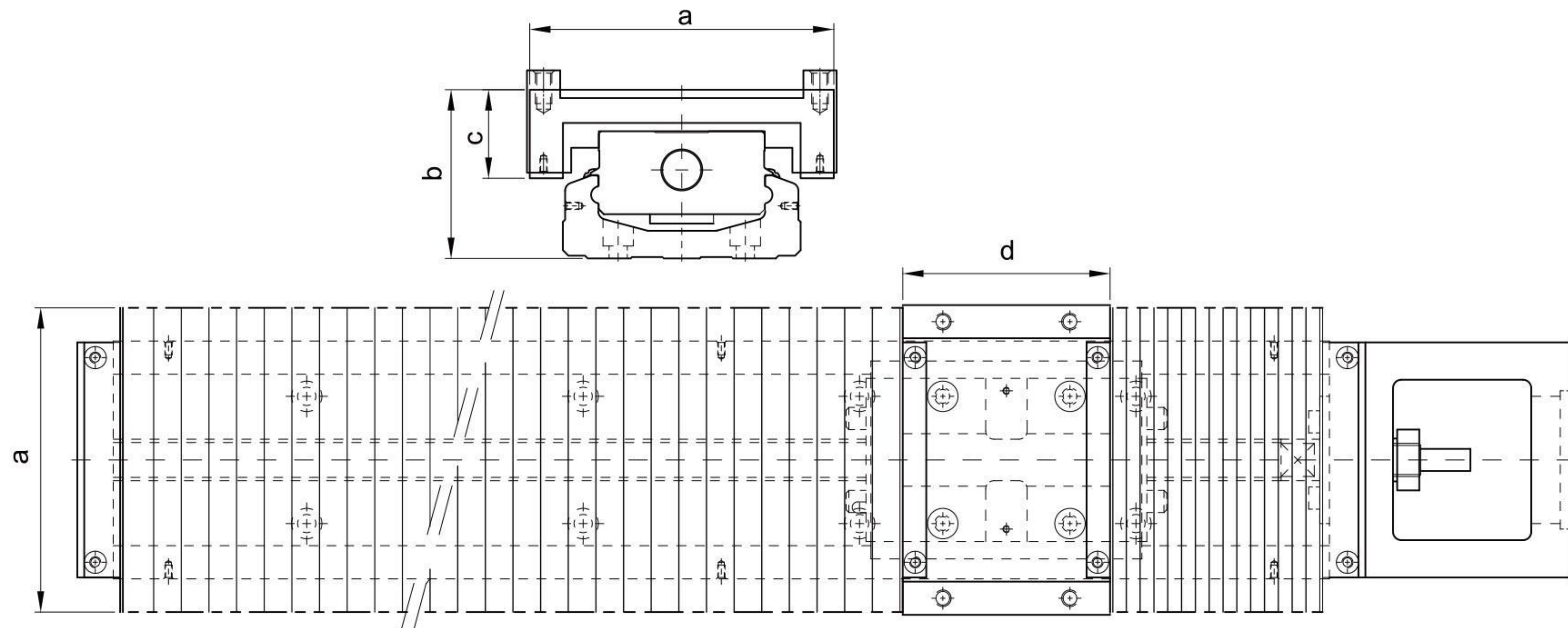

Nominal Width	Rail Length	Stroke	Min.	Max.	a	b	c	d
KK40	100	35	16	51	60	29.5	19	33
	150	63	27	90				
	200	93	37	130				
KK50	150	60	21.5	81.5	62	37	19	47
	200	95	29	124				
	250	130	36.5	166.5				
	300	160	46.5	206.5				
KK60	150	56	16	80	84	45.5	24	54
	200	106	20	126				
	300	166	40	206				
	400	234	56	290				
	500	306	70	376				
	600	366	90	456				
KK86	340	188	36	224	110	61	32	75
	440	260	50	310				
	540	336	62	398				
	640	408	76	484				
	740	480	90	570				
	940	640	110	750				
KK100	980	769	58	827	150	73	41	95
	1080	855	65	920				
	1180	945	70	1015				
	1280	1029	78	1107				
	1380	1115	85	1200				
KK130	980	748	62	810	180	89	53	108
	1180	916	78	994				
	1380	1084	94	1178				
	1680	1346	113	1459				



# Dimensions

## Switch rail

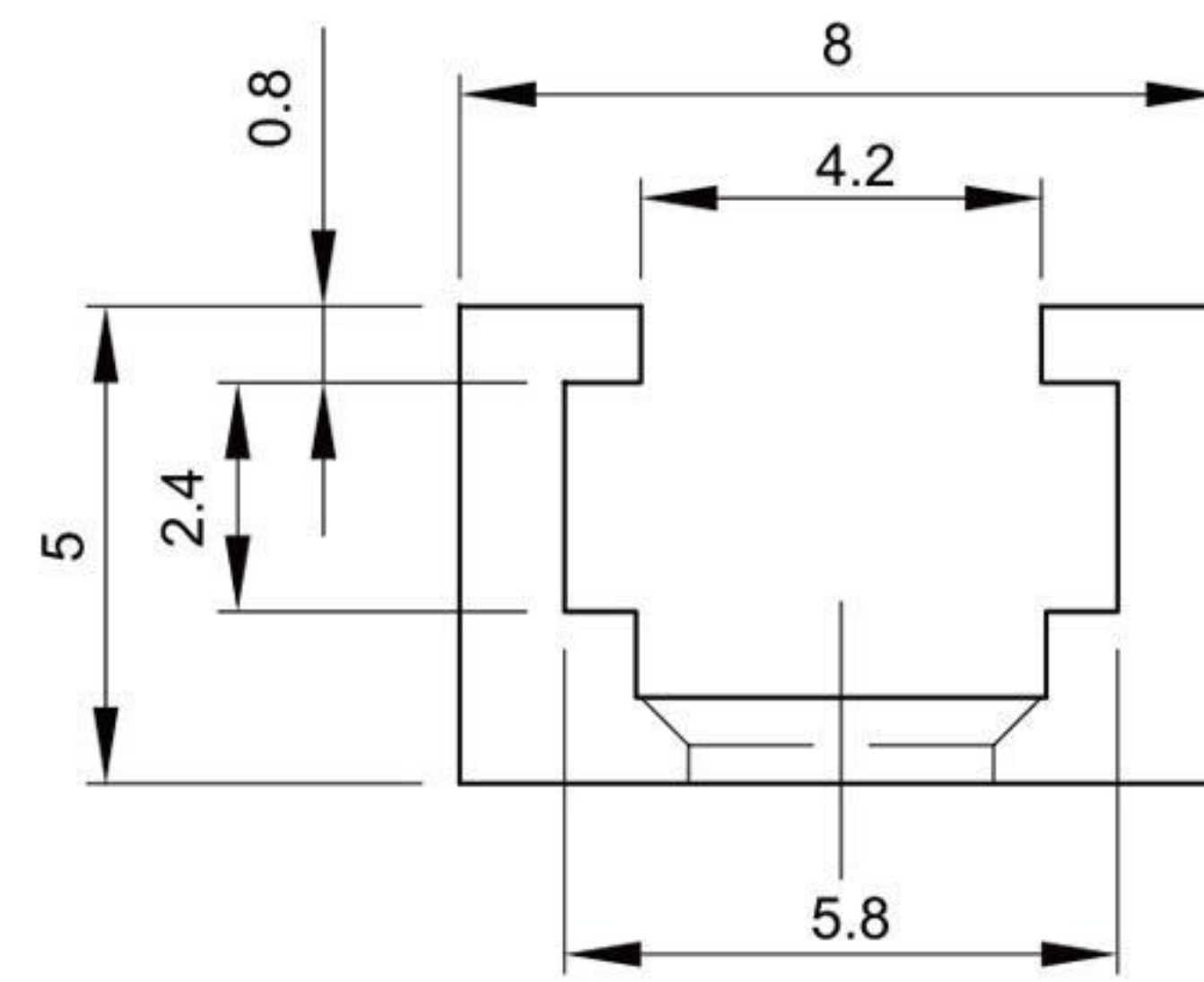

## Switch

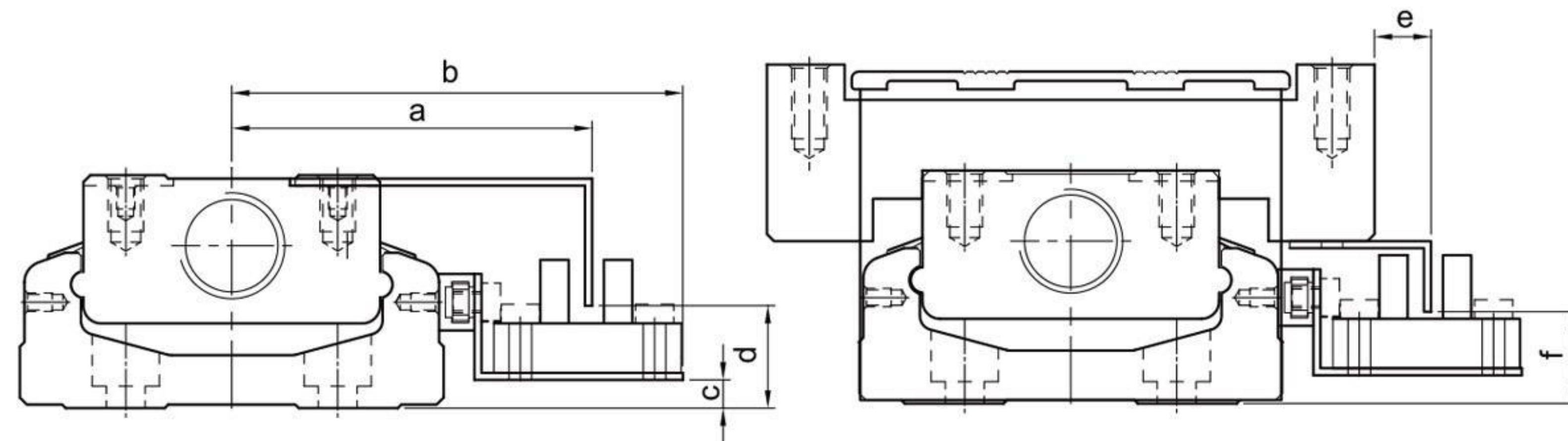

Nominal Width	a	b	c	d	e	f
KK40	41.5	54.1	0.5	10.8	15.3	12
KK50	45.5	59	1	10	15	11
KK60	51	63.8	4	14.5	8	13
KK86	63.5	76.7	8	18	8	18
KKR00	71	84	10	20	9	20
KK130	85.5	98.5	14	24	0.5	23

Switch 1 : Omron EE-SX671

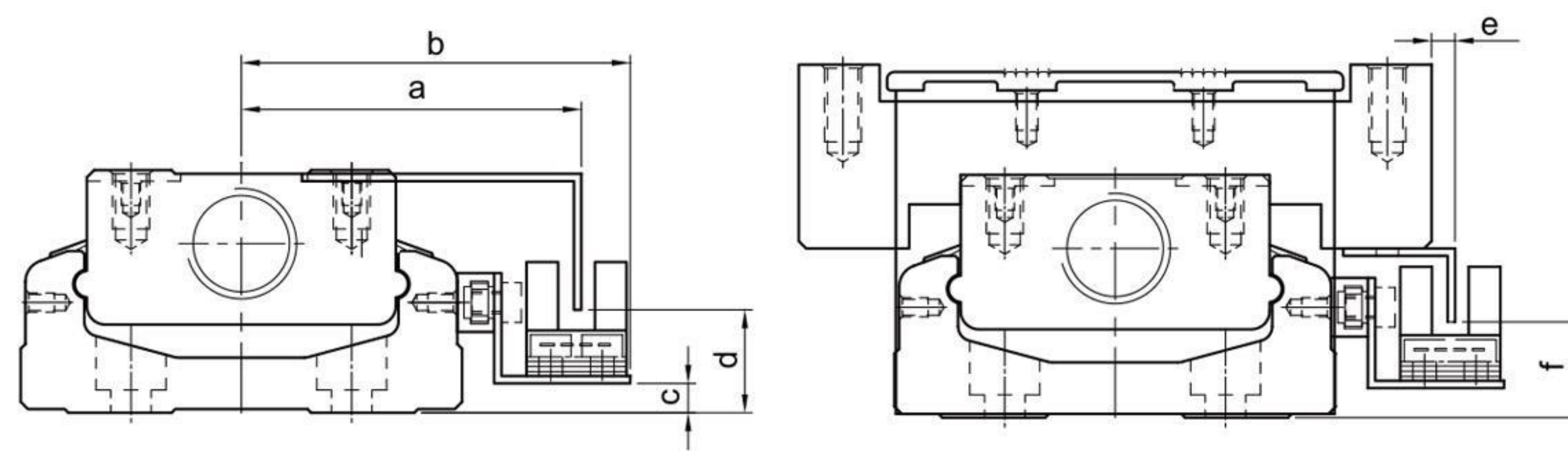

Nominal Width	a	b	c	d	e	f
KK40	36.5	44.3	1	9.8	10.5	12
KK50	41.3	48	1	10.5	10.2	11
KK60	46.2	52.8	4	14	3.2	13
KK86	59	65.7	8	18	3	18
KK100	66	73	10	20	4.2	20
KK130	80.8	87.5	14	23.5	-4.1	23.5

Switch 2 : Omron EE-SX674

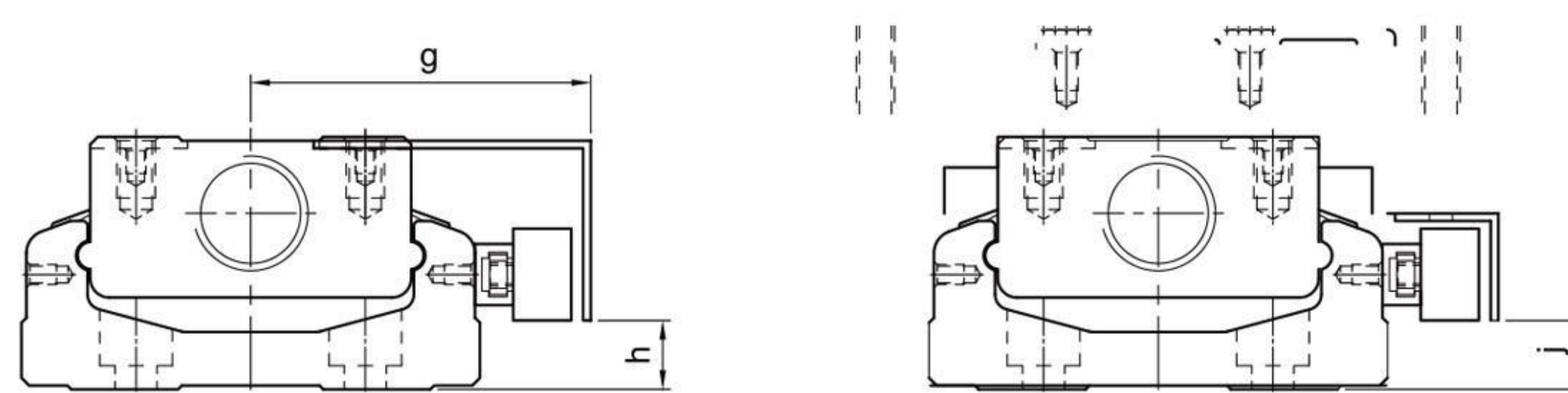

尺寸	g	h	i	j
KK40	40	5.5	13.5	5.5
KK50	39.5	5.7	7	19.5
KK60	44.5	9	2	9
KK86	57	13	1	13
KK100	64.5	15	2.5	15
KK130	79	19	-6	19

Switch 3, 4 : SUNX GX-F12A, SUNX GX-F12A-P