

Features

- LCD display, easy to understand
- High strength plastic shell, compression, and durable
- Low RJ45 cable interface, convenient
- The overall size is not big, small and beautiful, easily with other switch equipment Integrated installation
- Low load percentage and battery capacity



Specification

Models	RT-12
Connection Port	12VDC
applicable models	10-14VDC
Control	MOSFET
Apply to dc voltage	2
For ac voltage	10.5V
self-consuming	0.5W
Size (mm)/Weight (kg)	143*93*32/0.2kg

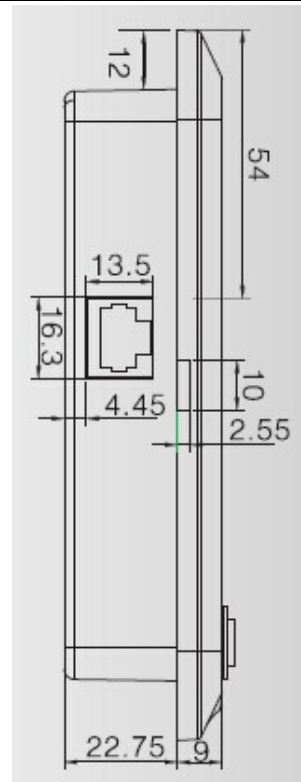
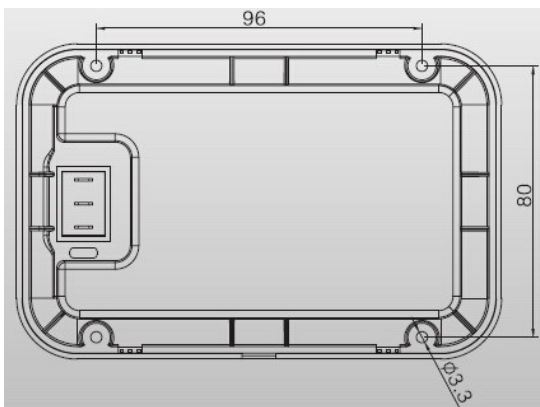
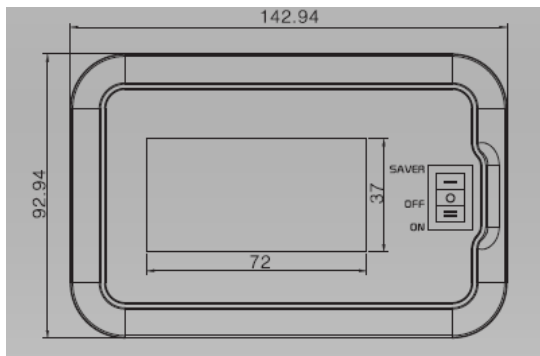

*Note: The Specifications are subject to changes without notice.