



NEG. CONTACT (PAD)

4.00 SQ. MIN

NOTE:

1. ALL INSIDE BEND RADII TO BE A MIN. OF MATERIAL THICKNESS UNLESS OTHERWISE SPECIFIED.
2. PART MUST BE FREE OF ALL BURRS AND SHARP EDGES.
3. MAT'L: 0.254 TH'K FULL HARD PHOSPHOR BRONZE
4. FINISH: NICKEL PLATE
0.00254-0.00762 NICKEL, OVER
0.00127-0.00254 COPPER
5. INDICATES CRITICAL DIMENSION

NOTES:

1. MATERIAL:
0.25mm PHOSPHOR BRONZE, NICKEL PLTD.
2. ROHS 2 COMPLIANT

Order code:

BS - M - SI - R - CR1225A
 ① ② ③ ④ ⑤

- ① BS: Battery Contacts
- ② Appearance for the product
M: SMT TYPE
S: 180 TYPE
- ③ Contact Plating
SI: NICKEL PLTD
SN: Tin
G0: Gold flash
G1: 3U" Gold
G2: 5U" Gold
G3: 10U" Gold
G4: 15U" Gold
G5: 30U" Gold
- ④ Packing method
A: Tray packing
R: Tape & reel packing
- ⑤ Product number
CR1225A

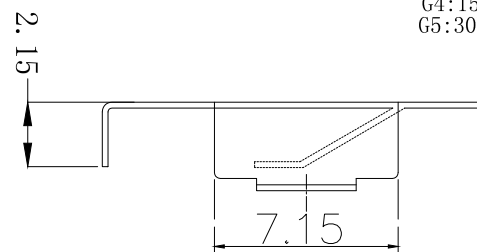
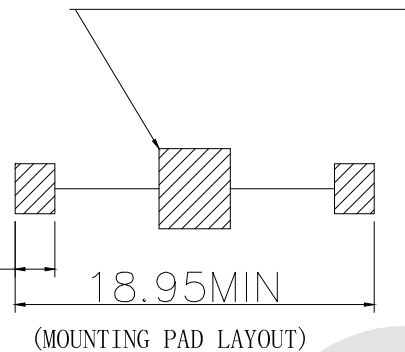
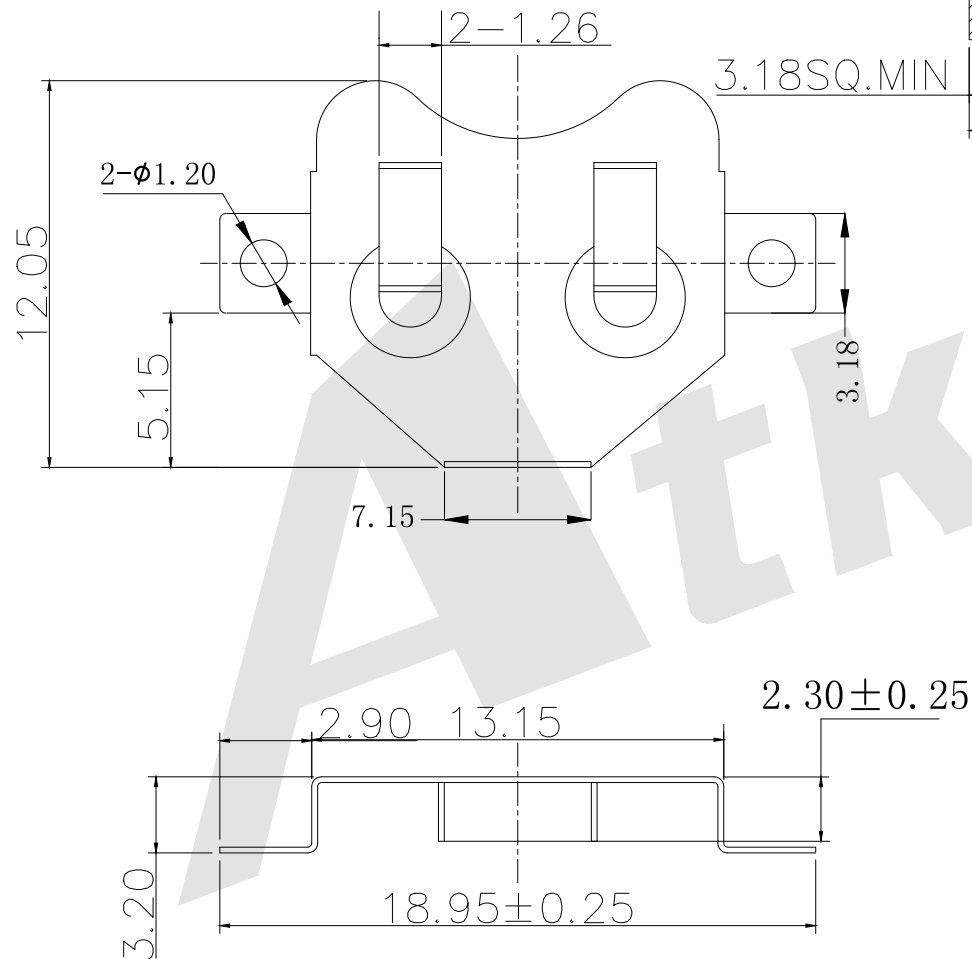

Unless Otherwise specified tolerance
 X. ±0.35 X.XX: ±0.20
 X.X: ±0.25 X.XXX: ±0.15

SCALE: As Shown UNIT: mm
 DRAW ZLA DATE 21/07/2022
 CHECK BobYang DATE 21/07/2022

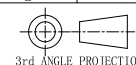

Atkconn® ATKCONN ELECTRONICS CO., LTD
[Http://www.atkconn.com](http://www.atkconn.com)

TITLE: BATTERY Contacts FOR CR1225 CR1216 CR1220

DRAWING NO: BS-M-SI-R-CR1225A

PRODUCT NO: BS-M-SI-R-CR1225A

REV	DESCRIPTION	DATE
1		
2		
3		
4		
5		