

HSF

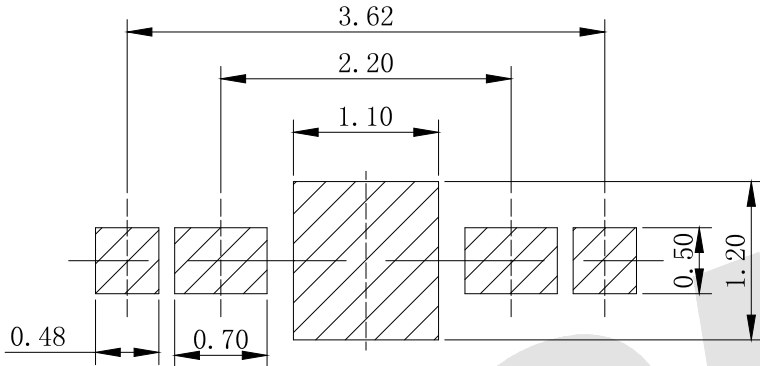

ROHS

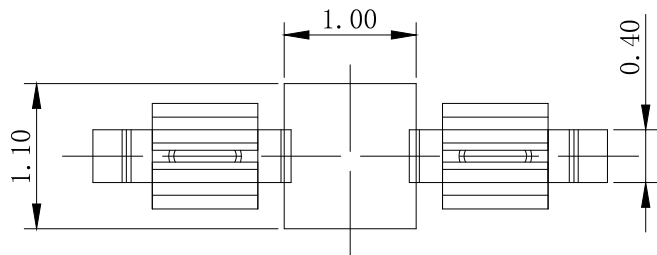

PCB LAYOUT (TOL: ±0.05)

NOTE:

Material: Stainless Steel, T=0.15mm

Electroplating: Tin Plating 1.0 ~ 3.0um

0.4 ~ 1.5um Nickel Base

SOLDERING DATA: SOLDERING HEAT RESISTANCE=250° C±5° /10S

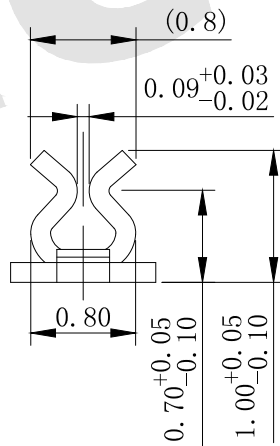
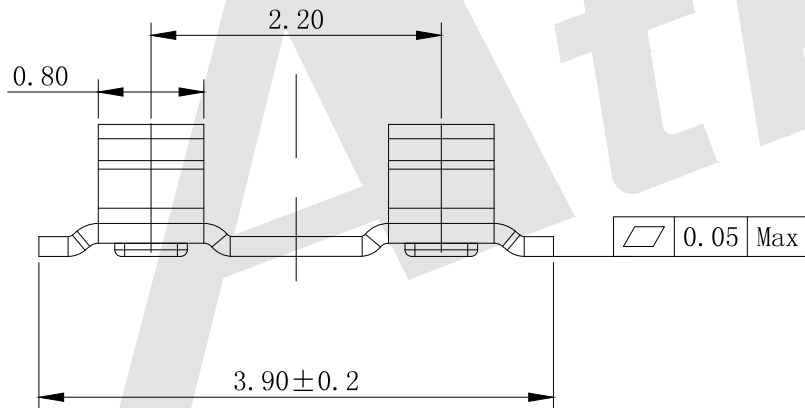

Ordering Code:

TBC.BT-S-SN-S0941-46-R

Contact Plating:
Material:
Stainless Steel

Packing Method
B: Bag Packing
R: Tape & Reel Packing

Contact Plating:
SN: Tin

Unless Otherwise specified tolerance
X. ±0.35 X.XX: ±0.20
X.X: ±0.25 X.XXX: ±0.15

SCALE: As Shown UNIT: mm
DRAW ZLA DATE 21/07/2022
CHECK BobYang DATE 21/07/2022

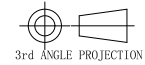

Atkconn® ATKCONN ELECTRONICS CO., LTD
[Http://www.atkconn.com](http://www.atkconn.com)

TITLE:
Battery Contacts S0941

DRAWING NO: TBC.BT-S-SN-S0941-46-R

PRODUCT NO: TBC.BT-S-SN-S0941-46-R

REV	DESCRIPTION	DATE
1		
2		
3		
4		
5		