

HSF

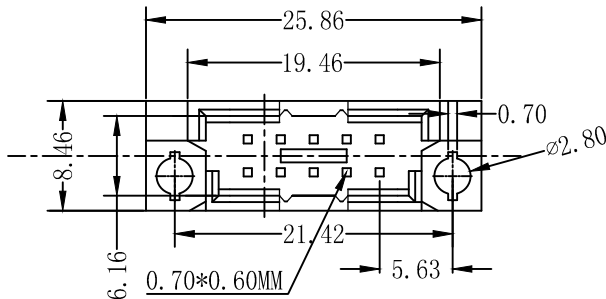

ROHS



Code	Number Of Contacts	Contact Arrangement	Rows With Contacts	Pitch
A	5		a	2.54
C	10		a	2.54

SPECIFICATION

Current Rating: 2.0Amp
 Insulation Resistance: 1000MΩ min.at DC 100V
 Contact Resistance: 20mΩ max
 Withstand Voltage: AC 1000V For 1 Minute
 Operating Temperature: -55° C to +105° C
 Contact Material: Brass
 Contact Plating: Au or Sn Over Ni
 Insulator Material: PBT+30%GF UL 94V-0
 Insertion Force: 20 pin max.18N
 Withdrawal Force: 0.15N min.per individual contact

Ordering Code:

DMS - XX - X - X - X - 220
 ① ② ③ ④ ⑤ ⑥

- ① Series No:
- ② No. of Contacts
10P 5P
- ③ Termination
 A: Straight solder tail length H=2.5mm
 E: Straight solder tail length H=4.0mm
 I: Straight tail length H=5.0mm
 K: Straight tail length H=7.4mm
 M: Wrap post tail length H=13.0mm
 N: Wrap post tail length H=17.0mm
 O: Wrap post tail length H=19.4mm
- ④ Rows Loaded With Contacts
 A: Row a
 C1: Row a+b (2, 4, 6...)
 C: Row a+b
- ⑤ Contact Plating
 G0: Gold flash
 S0: Gold flash/Ni
 G1: 3u" Gold
 S1: 3u" Gold/Ni
 G2: 5u" Gold
 S2: 5u" Gold/Ni
 G3: 10u" Gold
 S3: 10u" Gold/Ni
 G4: 15u" Gold
 S4: 15u" Gold/Ni
 G5: 30u" Gold
 S5: 30u" Gold/Ni
 SN: Tin
- ⑥ Series number
220

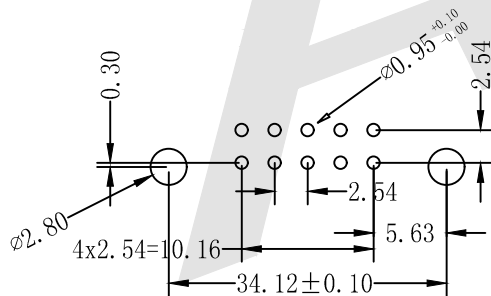
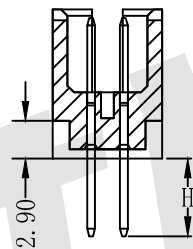
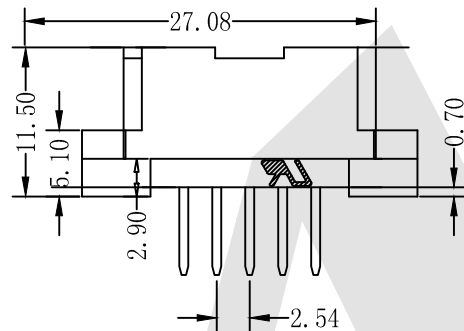

Recommended P. C. B. Layout

Unless Otherwise specified tolerance
 X. XX: ±0.20
 X. X: ±0.25 X. XXX: ±0.15
 X. ±0.35

Atkconn® ATKCONN ELECTRONICS CO., LTD
[Http://www.atkconn.com](http://www.atkconn.com)

SCALE: As Shown UNIT: mm
 DRAW ZLA DATE 24/04/2022
 CHECK BobYang DATE 24/04/2022

TITLE: DIM1612 Vertical Plug Type 1/3Q
 Connectors-Inversed 10 Positions

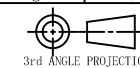

DRAWING NO: DMS-XX-XXX-220
 PRODUCT NO: DMS-XX-XXX-220

REV	DESCRIPTION	DATE