

HSF

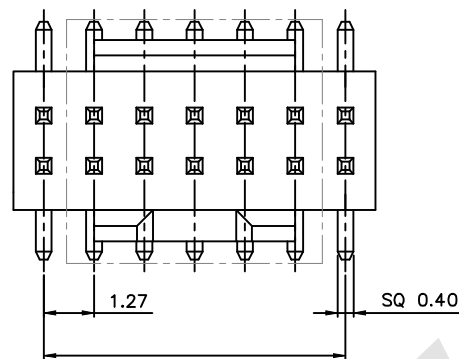

ROHS



1.27\*(N-1)

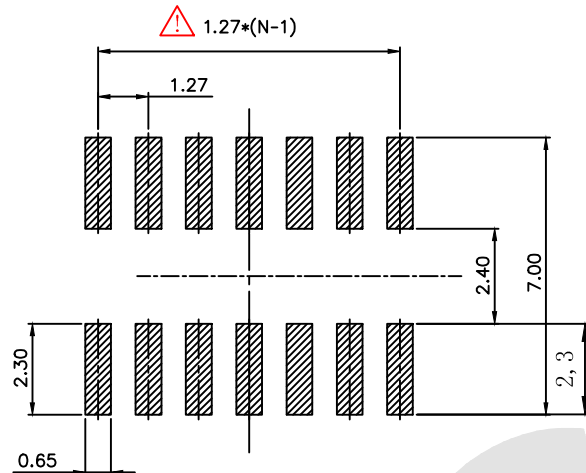

TOLERANCE: ±0.05, THICKNESS: 1.2mm  
RECOMMENDED PCB LAYOUT  
(TOP VIEW)

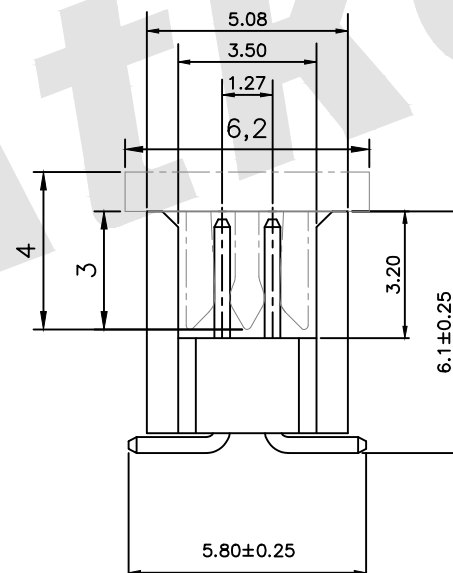
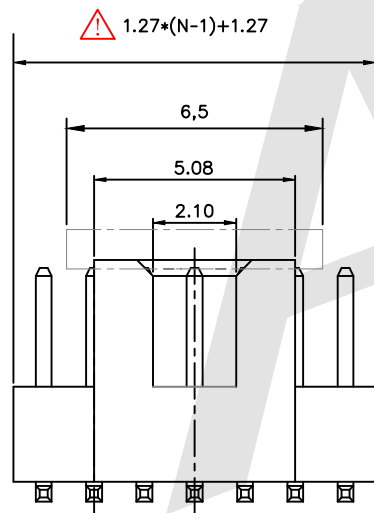

技术参数/Technical Parameters  
 符合规范/Accord With Norm :EIA-364C  
 额定电流/Current Rating :1AMP  
 绝缘阻抗/Insulator Resistance :1000Ω Min.  
 接触阻抗/Contact Resistance :20mΩ Max.  
 耐电压值/Voltage Resistance :AC 500V  
 工作温度/Operating Temperature :-40°C TO+105°C  
 金属材料/Metallic Material :Brass  
 金属处理/Metal Treatment :Ni+Au  
 绝缘材料/Insulator Material :LCP+30%GF UL94V-0  
 耐焊接热/Resistance To Soldering Heat:280° C±5° C 10S MAX

Ordering Code:

BHAM07 - X - X - X - X - X  
 ① ② ③ ④ ⑤ ⑥

- ① Series No:
- ② No. of Contacts  
10PIN, 14PIN, 20PIN
- ③ Contact Plating:  
G0:Gold flash S0:Selective  
G1:3U" Gold S1:Selective 3u"  
G2:5u" Gold S2:Selective 5u"  
G3:10u" Gold S3:Selective 10u"  
G4:15u" Gold S4:Selective 15u"  
G5:30u" Gold S5:Selective 30u"  
SN:Tin
- ④ Color Insulator  
B:Black  
U:Blue  
W:White
- ⑤ Insulator Material  
B:PA6T  
C:LCP  
E:PA9T
- ⑥ Packing  
A:Tray  
B:Bag  
T:Tube  
U:Tube+CAP  
R:Tape&Reel  
W:Tape&Reel+CAP

Unless Otherwise specified tolerance  
 X. ±0.35 X.XX: ±0.20  
 X.X: ±0.25 X.XXX: ±0.15

SCALE: As Shown UNIT: mm  
 DRAW ZLA DATE 24/04/2022  
 CHECK BobYang DATE 24/04/2022

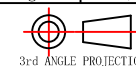

**Atkconn**® ATKCONN ELECTRONICS CO., LTD  
 Http://www.atkconn.com

TITLE:  
 1.27\*1.27MM BOX HEADER WITH THE KEY, SMT H=2.54MM  
 DRAWING NO: BHAM07-XGOBBW  
 PRODUCT NO: BHAM07-XGOBBW

| REV | DESCRIPTION | DATE |
|-----|-------------|------|
| 1   |             |      |
| 2   |             |      |
| 3   |             |      |
| 4   |             |      |
| 5   |             |      |