

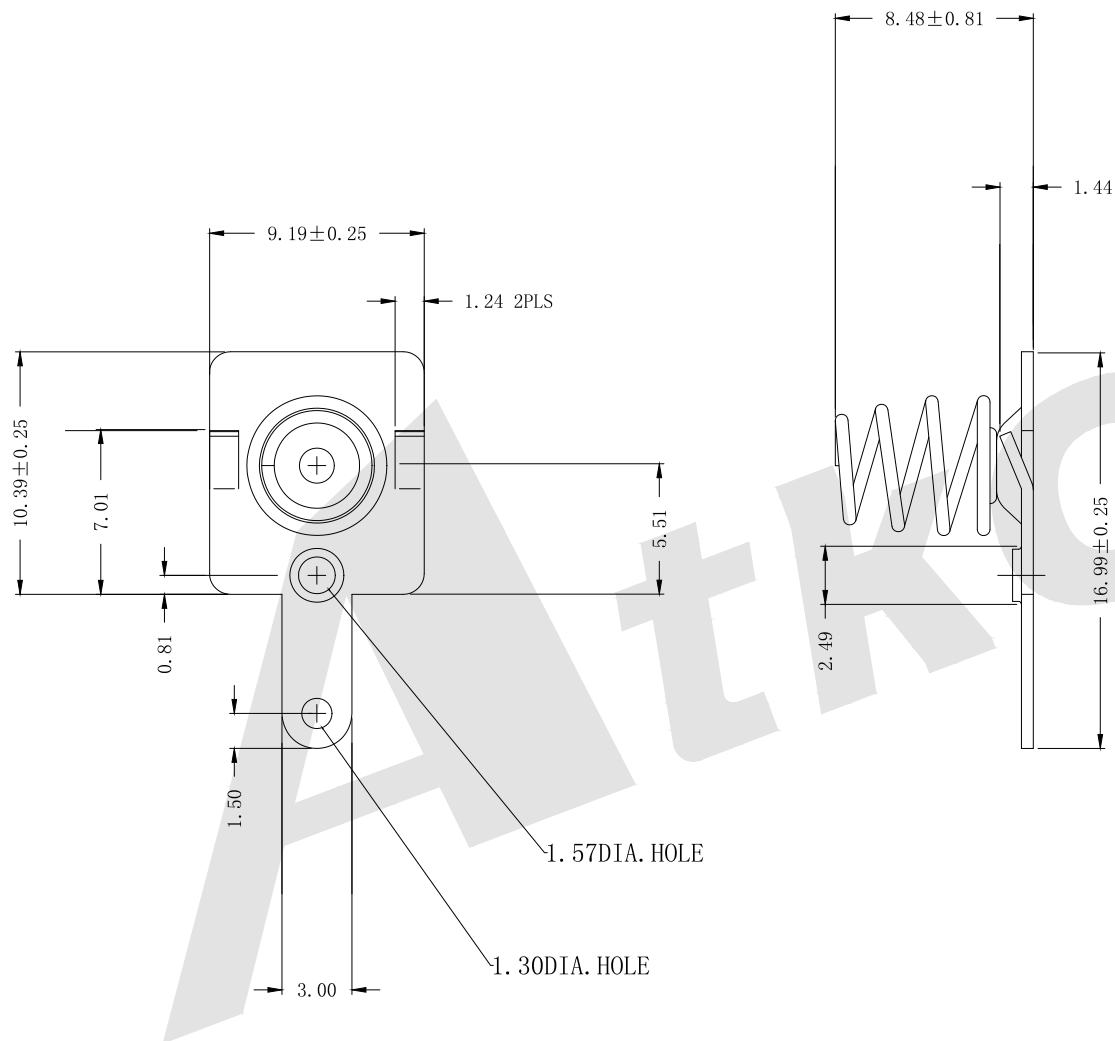

Technical Requirements:

1. Materials:0.5STEEL+0.58DIA.MUSIC WIRE FINISH NICKEL-PLATED.
2. COATING PARAMETERS:4um.
3. TEMPERATURE RANGE:-40° C~270° C
4. VOLTAGE PARAMETERS:270V



Order Code:

BS - S - SI - B - 151

①	②	③	④	⑤
---	---	---	---	---

① BS: Battery Contacts

② Appearance for the product  
S:180 TYPE

③ Contact Plating  
SI:Nickel Plate  
SN:Tin

G0:Gold flash  
G1: 3U" Gold  
G2: 5U" Gold  
G3:10U" Gold  
G4:15U" Gold  
G5:30U" Gold

④ Packing Method  
A: Tray Packing  
B: BAG PACKING  
R: Tape & Reel Packing

⑤ Product Number  
151

Unless Otherwise specified tolerance

X. ±0.35	X.XX:±0.20
X.X:±0.25	X.XXX:±0.15

SCALE: As Shown	UNIT: mm
--------------------	-------------

DRAW ZLA	DATE 21/07/2022
CHECK BobYang	DATE 21/07/2022

CHECK BobYang	DATE 21/07/2022
------------------	--------------------

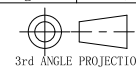

3rd ANGLE PROJECTION

**Atkconn**® ATKCONN ELECTRONICS CO., LTD  
Http://www.atkconn.com

TITLE:  
AAA 7# Cell Battery Contacts(Negative) 151

DRAWING NO: BS-S-SI-B-151

PRODUCT NO: BS-S-SI-B-151

REV	DESCRIPTION	DATE
1		
2		
3		
4		
5		