

Please read this user manual carefully before installation.

JTW-ZOM-TC5402W Wireless Addressable Heat Detector

User Manual

Version	Date	Author	Note
Ver1.1	Oct. 13, 2020	Zhao Jia; Wang Gang	1 st version

I. General

JTW-ZOM-TC5402W wireless addressable heat detector (hereinafter referred to as the detector) is a smart home fire detector that uses a high-precision thermistor as the sensor. It can be used with the company's wireless fire alarm control panel /wireless fire linkage control panel (hereinafter referred to as the device) for supporting use. The detector utilizes advanced wireless transceiver technology and a highly integrated micro-processing chip to process data. It has the characteristics of high sensitivity, long transmission distance, and low power consumption. It can accurately and quickly detect changes in ambient temperature, determine fire and call the police.

This product has beautiful appearance design, convenient and reliable installation, and is suitable for places where smokeless fires may occur, a large amount of dust or smoke and steam are trapped under normal circumstances. This product is widely used in various residential buildings. The fire can be detected as early as possible, and the people's lives and property can be protected to the greatest extent.

Note: This equipment has been tested and found to comply with the limits for a Class B digital device, pursuant to part 15 of the FCC rules. These limits are designed to provide reasonable protection against harmful interference in a residential installation. This equipment generates, uses and can radiate radio frequency energy and, if not installed and used in accordance with the instructions, may cause harmful interference to radio communications.

However, there is no guarantee that interference will not occur in a particular installation. If this equipment does cause harmful interference to radio or television reception, which can be determined by turning the equipment off and on, the user is encouraged to try to correct the interference by one or more of the following measures:

- Reorient or relocate the receiving antenna.
- Increase the separation between the equipment and receiver.
- Connect the equipment into an outlet on a circuit different from that to which the receiver is connected.
- Consult the dealer or an experienced radio/TV technician for help.

Important: You are cautioned that changes or modifications not expressly approved by the party responsible for compliance could void the user's authority to operate the equipment.

This device complies with part 15 of the FCC Rules. Operation is subject to the following two conditions: (1) This device may not cause harmful interference, and (2) this device must accept any interference received, including interference that may cause undesired operation.

Any Changes or modifications not expressly approved by the party responsible for compliance could void the user's authority to operate the equipment.



II. Features

1. Using advanced wireless transceiver technology, signal transmission can be completed without wiring, and the project is simple and convenient.
2. Using 470MHz frequency band communication, FSK coding technology, strong anti-interference ability, long transmission distance;
3. With battery low-voltage detection, remind users to replace when the battery is insufficient to maintain the detector's normal operation.
4. The use of high-sensitivity thermal elements improves the response speed of the temperature detector to temperature changes.

III. Technical Specifications

1. Type: A2R
2. Battery type: CR17450 3V
3. Working Current: Standby Current $\leq 3\mu\text{A}$
Alarm Current $\leq 18\text{mA}$
4. Indicators: Fire Indicator: red, always on when it alarms
Fault Indicator: yellow, flash twice every 48s when the battery is undervoltage. Periodic flashing when communication fails after entering the network
Working Indicator: Green, flashing periodically when the communication is normal after entering the network
5. Coding method: The control panel is automatically assigned during networking
6. Communication method: 470MHz FSK Coded two-way communication
7. Communication distance: $\leq 50\text{m}$
8. Transmitting power: $< 20\text{dBm}$
9. Frequency band: 470MHz
10. Protection area: When the height of the space is less than 8m, the protection area of a detector is $20\text{m}^2 \sim 30\text{m}^2$ for the general protection site. The specific parameters should be based on the "Code for Design of Automatic Fire Alarm System" (GB 50116-2013).
11. Use environment:
Atmosphere pressure: $86\text{kPa} \sim 106\text{kPa}$
Temperature: $-10^\circ\text{C} \sim +50^\circ\text{C}$
Relative humidity $\leq 95\%$, non-condensing
12. Dimensions: diameter 100mm, high 54mm (with base)
13. Protection grade: IP30

14. Material and color: ABS, off-white

15. Weight: about 110g (including battery)

16. Installation hole distance: 60mm

17. Executive standard: GB 4716-2005 "Point Type Temperature Sensing Fire Detector"

XF 1151-2014 "General Requirements for Wireless Communication Function of Fire Alarm System"

IV. Structure and Working Principle

1. The outline diagram of the detector is shown in Figure 1.

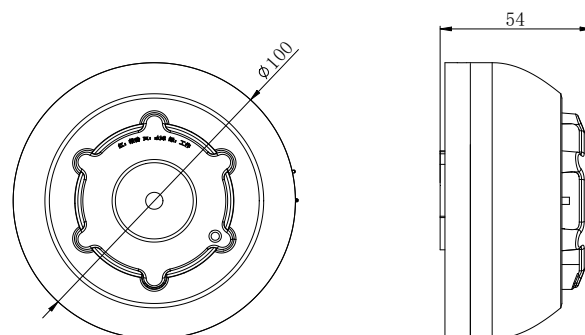

Fig.1 Outline diagram of the detector

2. Working principle

The detector uses a high-precision thermistor sensor, and the output signal of the sensor is input to the single-chip microcomputer after voltage conversion, and the single-chip uses an intelligent algorithm for signal processing. When the temperature in the environment reaches the alarm value, the red light of the detector will be on, and an alarm signal will be sent to the control panel wirelessly. When used as a fire alarm device, the detector is in the state of waiting for the control panel to reset during this process. If the fire alarm is not cleared, the detector will resend the fire alarm signal to the control panel every ten minutes.

V. Installation

Warning: Before installing the detector, please make sure that the battery polarity is correct and that the base has been installed firmly.

1. Installation method

The schematic diagram of the detector installation is shown in Figure 2.

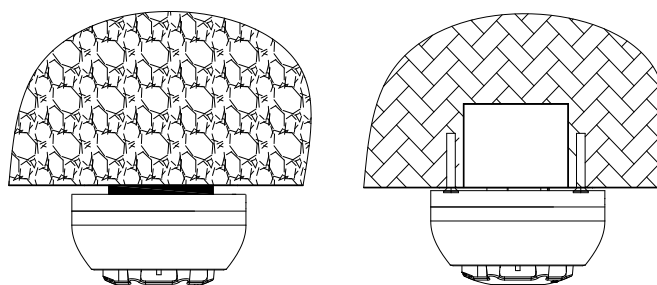

Figure 2 Schematic diagram of the detector installation

The schematic diagram of the base of the detector is shown in Figure 3. Fix the base with two self-tapping screws or stick it firmly with 3M glue. After the base is firmly installed, align the bottom of the detector and rotate the base clockwise to install the detector on the base.

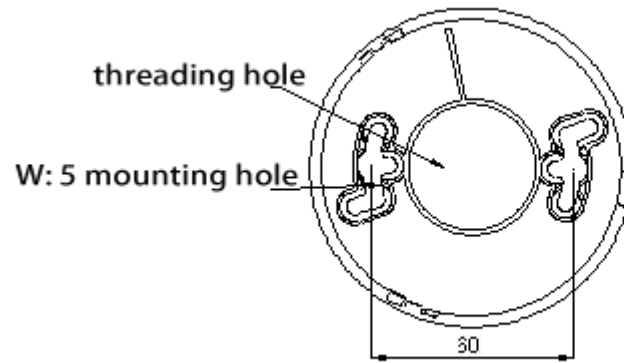

Fig.3 Schematic diagram of the base of the detector

1. Points for on-site installation

The wireless performance indicators of this product will vary according to the actual use environment. The construction personnel should strictly follow the communication requirements of the wireless product and set the working network segment of the wireless fire alarm system in accordance with the actual working environment of the installation site.

VI. Test

Warning: Please make sure that the polarity of the battery is correct before proceeding.

1. The detector must be tested after installation or after each regular maintenance.
2. Simulated fire alarm: After successfully connecting to the network, choose a detector to make it meet the fire alarm conditions artificially (please turn off the fire alarm linkage function to avoid unnecessary alarm linkage), and verify whether the detector reports the fire alarm normally. After the test is over, pass The control panel sends a communication command to reset the detector and informs the relevant management department to restore the system to normal.
3. During the test, the unqualified detector shall be dealt with according to "general failure and repair" and "maintenance", and then be tested. If it still fails to pass the test, it should be returned to the factory for repair.

VII. Use and Operation

1. Network segment setting: Before the detector connects to the network, you should first set the device network segment. Select the network setting on the menu interface of the control panel . After entering the network setting, first set the local address number, and then set the detector to the network according to the actual situation on site Segments (29 options).

2. The device enters and exits the network: After the detector is powered on, press the "Indicators" button once, the green light flashes once, the detector sends an online command to the control panel , and the control panel displays the detector loop address number, indicating that the detector has successfully connected to the network , Otherwise the detector is not connected to the network. The detector sends online commands for 3s, during which other functions of the keys are disabled.

A) Network access operation: When the control panel is in the "wireless registration interface" and the detector is not connected to the network, quickly press the "Indicators" button three times, the green light flashes three times, the detector sends a network access application to the control panel , and the application is successful After that, the total number of network access displayed by the control panel is +1, and the detector sends a network access request for 3 seconds. During this period, other functions of the button are disabled.

B) Network exit operation: When the control panel is in the "wireless registration interface" and the detector is in the network connection state, quickly press the "Indicators" button three times, the green light flashes three times, and the detector sends an exit request to the control panel . After the application is successful, the total number of logout displayed by the control panel is +1, and the detector sends a logout request for 3s. During this period, other functions of the button are disabled.

3. Equipment alarm: When the temperature in the environment reaches or exceeds the alarm temperature set by the detector, the red light of the detector will be on, and an alarm signal will be sent to the control panel wirelessly. After the control panel responds to the alarm signal, the control panel will display a fire alarm. , The detector is in the state of waiting for the control panel to reset. After confirming that the fire alarm is released, the control panel can send a signal to reset the detector.

4. Device reset: When the device reports a fire alarm and the control panel responds, it can be reset by operating the control panel. After the detector receives the reset signal, it will perform the reset operation.

5. Restore factory settings: After the detector is connected to the network, when it is powered on again, the red indicators will be on for 10s; during this period, the factory settings can be restored by pressing the button five times.

Note: The button function only has one click, three consecutive clicks, five consecutive clicks, long press function, and other button methods are invalid.

VIII. General failure and repair

General faults and their solutions are shown in the table below :

Fault	Reason	Solution
No status prompt on the control panel after device alarms	The device is not connected to the network	Restart the network operation
Device networking is unsuccessful	Too far away from the control panel or interference sources nearby	Move the device near the controller, reconnect to the network and remove the source of interference
Red light is off	Low battery or no battery inserted	Replace battery

IX. Maintenance

1. The detector should take corresponding moisture-proof and anti-corrosion measures.
2. The detector is cleaned at least once a year to ensure the normal operation of the system. Before the detector is cleaned, the relevant management department should be notified that the system will be maintained, and the logical control function of the area or the system that will be maintained should be closed to avoid unnecessary alarm linkage.
3. The detector should conduct a simulated fire alarm test every six months to test whether the detector works normally.

10. Matters needing attention

1. The horizontal distance between the detector and the air supply hole of the air conditioner should not be less than 1.5m.
2. The horizontal distance from the detector to the wall and beam side should not be less than 0.5m.
3. The detector should be installed horizontally. If it must be installed at an angle, the inclination angle should not be greater than 45°.
4. When the detectors are installed on the ceiling of the inner walkway with a width less than 3m, they should be arranged in the center, and the installation distance of the temperature sensing detectors should not exceed 10m.
5. After the signal passes through the wall, the signal strength will be greatly attenuated, so try to reduce the number of partition walls for wireless products.
6. When installing the product, keep it away from metal to reduce the shielding of the signal from metal objects. For example, it cannot be installed in a metal box such as a fire hydrant box or outside of a metal cabinet.
7. Install in a low-interference environment and far away from motors or large-scale electrical equipment.

11. Documents and warranty instructions

1. Packing documents: 1) Packing list: 1
- 2) Instructions: 1 copy

2. Warranty: Our company is responsible for the maintenance of this product. If you find any problems, please contact our company's technical service department in time. Users are not allowed to disassemble or repair by themselves, otherwise the consequences will be at their own risk.

3. The maintenance contact information is as follows:

Liaoning • Yingkou Tiancheng Fire Equipment Co., Ltd.

Address: No. 11-2, Kechechang Xili, Xishi District, Yingkou, Pilot Free Trade Zone (Liaoning) China , City

Fax: 0417-4835568

Postcode: 115004

Tel: 400-6930-119

Email: info@tcfiretech.com

Website: www.tcfiretech.com