

南京全宁电器有限公司
Nanjing QuanNing Electric Co.,Ltd

江苏省南京市江宁区东山科创园润麒路 68 号

TEL: (025) 52628081

FAX: (025) 52628051

E-MAIL: nnlppsooss@163.com

CUSTOMER		MODEL NO	QNR20A-G-24
----------	--	----------	-------------

产品外形图



ORDER DESIGNATION (订货标记)

QNR 20A — □ — □

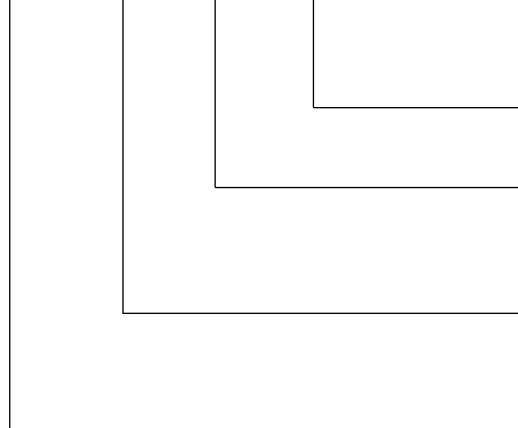

线圈电压rating voltage

结构形式:G 表示环氧密封 Structure form:G indicates Epoxy seal

负载电流: 直接表示负载电流大小和单位

Rated operating current

接触器型号Contactor ts

南京全宁电器有限公司
NanJing QuanNing Electric Co., Ltd.

江苏省南京市江宁区东山科创园润麒路 68 号

QNR20A 高压直流接触器

QNR20A high voltage DC contactor

1、产品应用范围

QNR20A 高压直流接触器用于包括电动汽车辅助电气切换控制、预充电控制、电动汽车、快速充电桩、电池切换和电动摩托车高压直流电压开关控制、电路保护及安全控制等。

QNR20A high voltage DC contactor is used for auxiliary electrical switching control of electric vehicle, precharge control, electric vehicle, fast charging pile, battery switching and high voltage DC voltage switching control of electric motorcycle, circuit protection and safety control, etc.

2、特点:

- 带电能力 20A 以上，在 320VDC 下可切断 2000A 电流，体积小，重量轻；

20A+ charging capacity, can rupture 2000A current at 320VDC; Small size, light weight.

- 开关部分和驱动部分是充气的、密封性的，使得其可以切断高容量负载；

The switch part and the driving part are inflated and sealed to cut off the high-capacity load.

- 全密封结构，安全性高；用于易爆或有害 在使用环境中，其线圈和触点不氧化，即使长时间不工作也是如此；

The switch part and the driving part are inflated and sealed to cut off the high-capacity load.

- 产品设计符合标准：IEC60947-4， GB14048.4；

Product standard: IEC60947-4, GB14048.4

- 产品通过的认证：CE 认证。

Certification: CE

3、产品技术参数Specification:

●触点参数:

产品型号 (见型号说明)		QNR20A-G-24
主触点 contact	额定绝缘电压 Rated Insulation Voltage Ui (V)	1000
	额定工作电压 rating voltage Ue(V DC)	≤900
	约定发热电流 Conventional thermal current Ith(A)	20
	额定工作电流 Rated operating current Ie (DC-1 A)	20
	接触电阻 resistance	≤2mΩ (12VDC/10A)
	最大切换电压 MAX Voltage switching	1000VDC
	最大切换电流 MAX Current switching	100A/320V
	过载切断 Overload cut-off	320VDC 下 100A, 1 次 320VDC 100A Once
	触点形式contact form	一组桥式常开 Bridge 1NO

●性能参数:

绝缘电阻Insulation resistance	$\geq 100M\Omega / 500VDC$	
介质耐压Initial Dielectric Strength	线圈与触点间Between Contacts and Coil	3000VAC/min
	断开触点间Between The Open Contacts	
电气寿命 (阻性负载) Electrical endurance (Resistive load)	1×10^4 次 (320V, 20A)	
机械寿命Mechanical endurance	20×10^4 次	
动作时间active time	$\leq 20ms$ (包括触点弹跳时间)	
释放时间Release Time	$\leq 12ms$	
冲击impulse	11ms, 1/2 正弦波sine, 峰值peak value, $196 m/s^2$	
振动Vibration	正弦波sine, $10 \sim 2000Hz$, 峰值peak value, $196 m/s^2$	
使用环境温度Ambient Temperature	$-40 \sim 85^\circ C$	
使用环境湿度Ambient Humidity	5%~85%RH	
端子形式Wiring Terminal form	螺纹连接型Thread connection type	
封装形式encapsulation form	充气密封型Inflatable seal type	
重量weight	~ 120g	

●线圈工作电压 (适用于整个温度范围) :

标准电压Standard voltage	12VDC	24VDC	48VDC
工作电压working voltage	9.6~13.2VDC	19.2~26.4VDC	38.4~52.8VDC
最大电压MAX voltage	15VDC	30VDC	60VDC
最小吸合电压MIN pull voltage	9.6VDC	19.2VDC	38.4VDC

4、电寿命曲线:

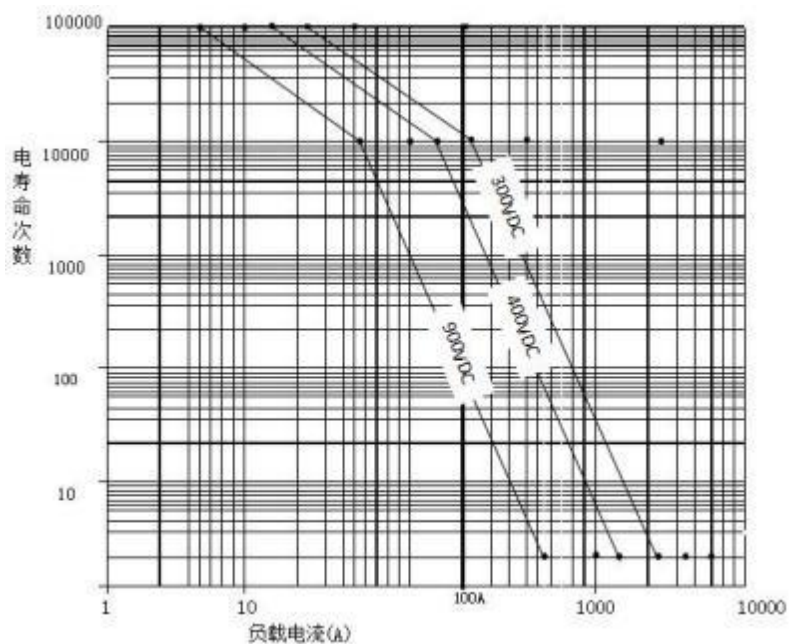

5、外形及尺寸：

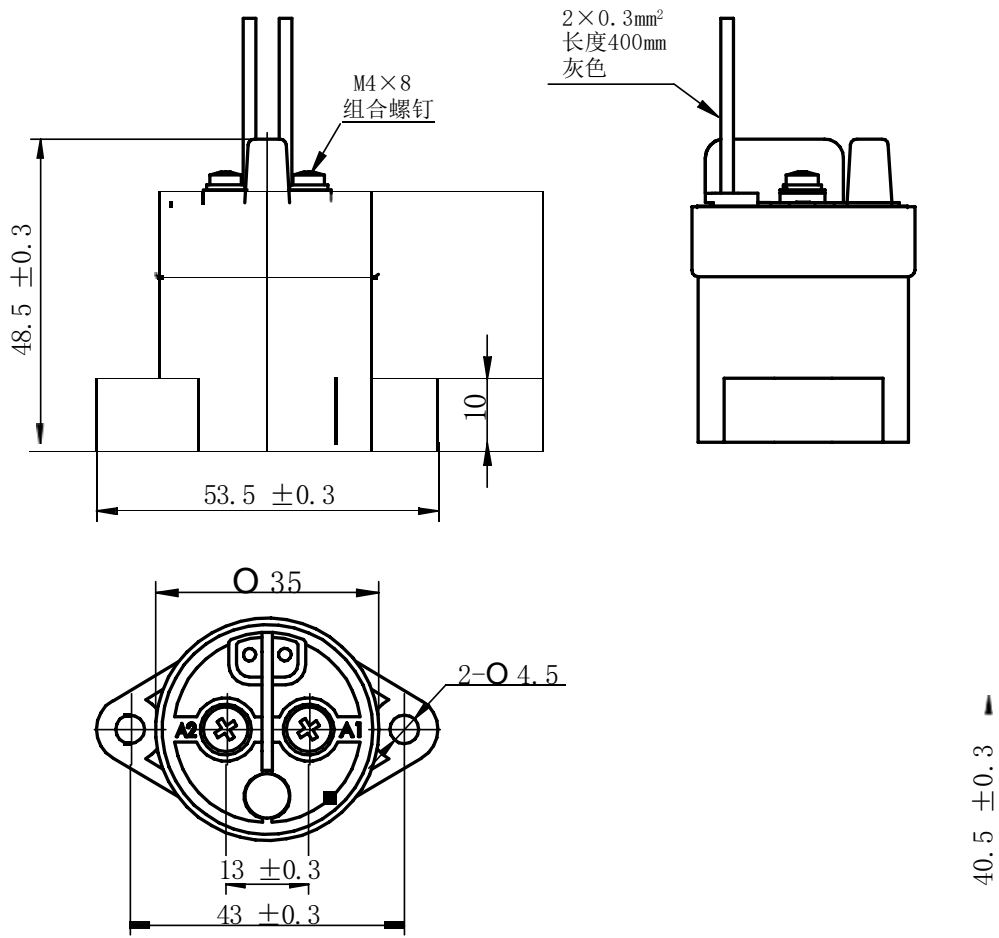

6、接线图：

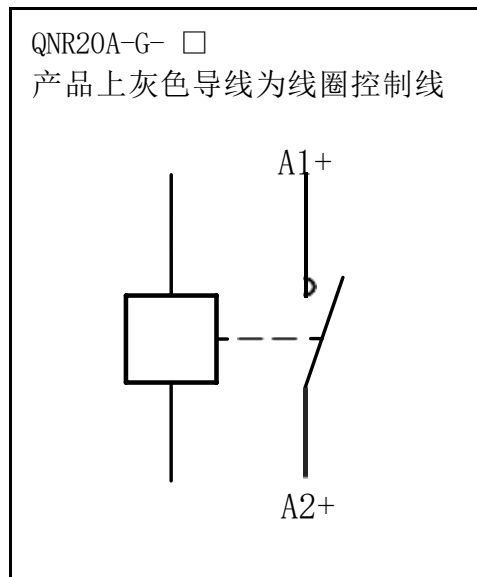

7、应用注意事项:

- 不要在继电器通电状态下，触摸负载接线端子，谨防触电危险；

Do not touch the relay terminal when it is energized or in danger of electric shock

- 当对控制回路及非金属材料做耐压测试时，应断开负载电压；

Disconnect the load voltage when the voltage withstand test is conducted on the control circuit and non-metallic materials

- 避免将产品安装在强磁场的地方（变压器或磁铁），或靠近热辐射的物体；

Avoid installing the product in places with strong magnetic fields (transformers or magnets) or near objects with heat radiation

- 不要将杂物和油污沾到主引出端子，且外引线端子与主引出端子可靠接触，否则会造成端子发热很厉害，导致连接电缆熔化；

Do not stick sundries and oil stains on the main outgoing terminal, and the external lead terminal shall be in reliable contact with the main outgoing terminal, otherwise the terminal will be heated seriously and the connecting cable will melt

- 在进行动作电压测试时，不要使电压缓慢上升，请通过阶跃式供电方式对线圈驱动；

Please drive the coil through step power supply instead of making the voltage rise slowly during the action voltage test

- 各安装部位螺柱锁紧扭矩控制在规定的范围。负载安装部位的螺钉拧紧力矩为 $2\sim 3\text{N} \cdot \text{m}$ ；安装部位螺钉拧紧力矩为 $2\sim 3\text{N} \cdot \text{m}$ ；

Install within the specified range. The tightening torque of the screws at the load installation position is $2 \sim 3\text{N} \cdot \text{m}$; The tightening torque of the screws at the installation position of the contactor is $2\sim 3\text{N} \cdot \text{M}$

- 在继电器意外跌落并受到冲击地情况下，原则上请不要使用

Do not use the relay in case of accidental drop and impact