

南京全宁电器有限公司
Nanjing QuanNing Electric Co.,Ltd
江苏省南京市江宁区东山科创园润麒路 68 号

TEL: (025) 52628081

FAX: (025) 52628051

E-MAIL: nmlppsooss@ 163.com

CUSTOMER		MODEL NO	QNZ-100A DC72V
----------	--	----------	----------------

产品外形图



ORDER DESIGNATION (订货标记)

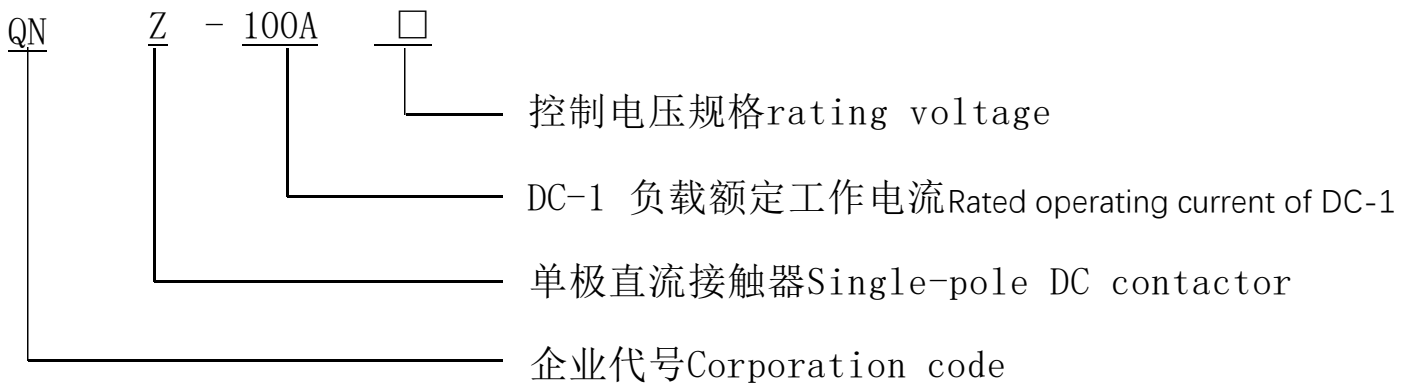

南京全宁电器有限公司 Nanjing QuanNing Electric Co.,Ltd

江苏省南京市江宁区东山科创园润麒路 68 号

TEL: (025) 52628081

FAX: (025) 52628051

E-MAIL: nmlppsooss@163.com

产品应用范围: 蓄电池车辆、牵引机车、不间断电源系统、软启动

Application: Soft starter, battery driven vehicle, traction locomotive, uninterruptible power supply system

产品设计符合标准: IEC60947-4, GB14048.1, GB14048.4, JB2286-78, JB3974-85, YD/T585-92, YD/512-92

Standards: IEC60947-4, GB14048.1, GB14048.4, JB2286-78, JB3974-85, YD/T585-92, YD/512-92

产品通过的认证Certification: CCC 认证

产品技术参数Specifications:

CUSTOMER		MODEL NO	QNZ-100A DC72V
ELECTRICAL SPECIFICATION			
PRIMARY			
环境温度 Ambient Temperature		-25℃~+85℃	
振动 Vibration		频率 1~50Hz 振幅 25±1mm	
海拔高度 Height above sea level		≤3000m	
触点形式 Contact Form		1NO	
额定工作电压 Rated working voltage		DC48V	
额定工作电流 DC-1 Rated operating current Ie		100A	
触头接触电阻 Contact resistance mΩ		≤0.6mΩ	
约定发热电流 Conventional thermal current Ith A		100A	
操作频率 h ⁻¹ Use frequency h ⁻¹		600	
额定绝缘电压 Insulation Resistance		1500V	
介质耐压 Initial Dielectric Strength	线圈触点间 Between Contacts and Coil	3500V/1Min 无击穿或闪络现象, 且泄露电流≤5mA 3500V/1Min No breakdown or flashover, And leakage current ≤5mA	
	开路触点间 Between Open Contacts	3500V/1Min 无击穿或闪络现象, 且泄露电流≤5mA 3500V/1Min No breakdown or flashover, And leakage current ≤5mA	
电气寿命 (DC-1) Electrical Life (DC-1)		5×10 ⁴ 次	
温升 Elevatory temperature	线圈 (额定控制电压下) Coil (Rated control voltage)	≤85K	
	接线端子 (额定工作电流下) Terminal blocks (Rated operating current)	≤70K	
	外壳 Outer Shell	<70K	
漆包线 magnet wire	耐温 Temperature Resistance	≤180℃	
	绝缘等级 Insulation grade	H 级	
	耐压 (漆层对地) Pressure resistance (paint layer against ground)	1000V/1Min 无击穿或闪络现象, 且泄露电流≤5mA	

线圈参数 (在 20℃下) COLLDATE (AT 20℃)

额定电压 RATED VOLTAGE (V DC)	启动电流 Starting Current (A)	保持电流 Holding Current (A)	吸合电范围 PULL IN CURRENT RANGE (V DC)	释放电压范围 DROP VOLTAGE RANGE (V DC)	吸合功率 PULL IN POWER (VA)
72	<0.1	<0.07	61.2-79.2	7.2-43.2	<8

可根据客户要求特殊定做 Specifications can be made according to customer's order.

南京全宁电器有限公司

Nanjing QuanNing Electric Co.,Ltd

江苏省南京市江宁区东山科创园润麒路 68 号

TEL: (025) 52628081

FAX: (025) 52628051

E-MAIL: nllppssooss@163.com

CUSTOMER		MODEL NO	QNZ-100A DC72V
----------	--	----------	----------------

OVERALL AND MOUNTING DIMENSIONS (外型尺寸与安装尺寸)

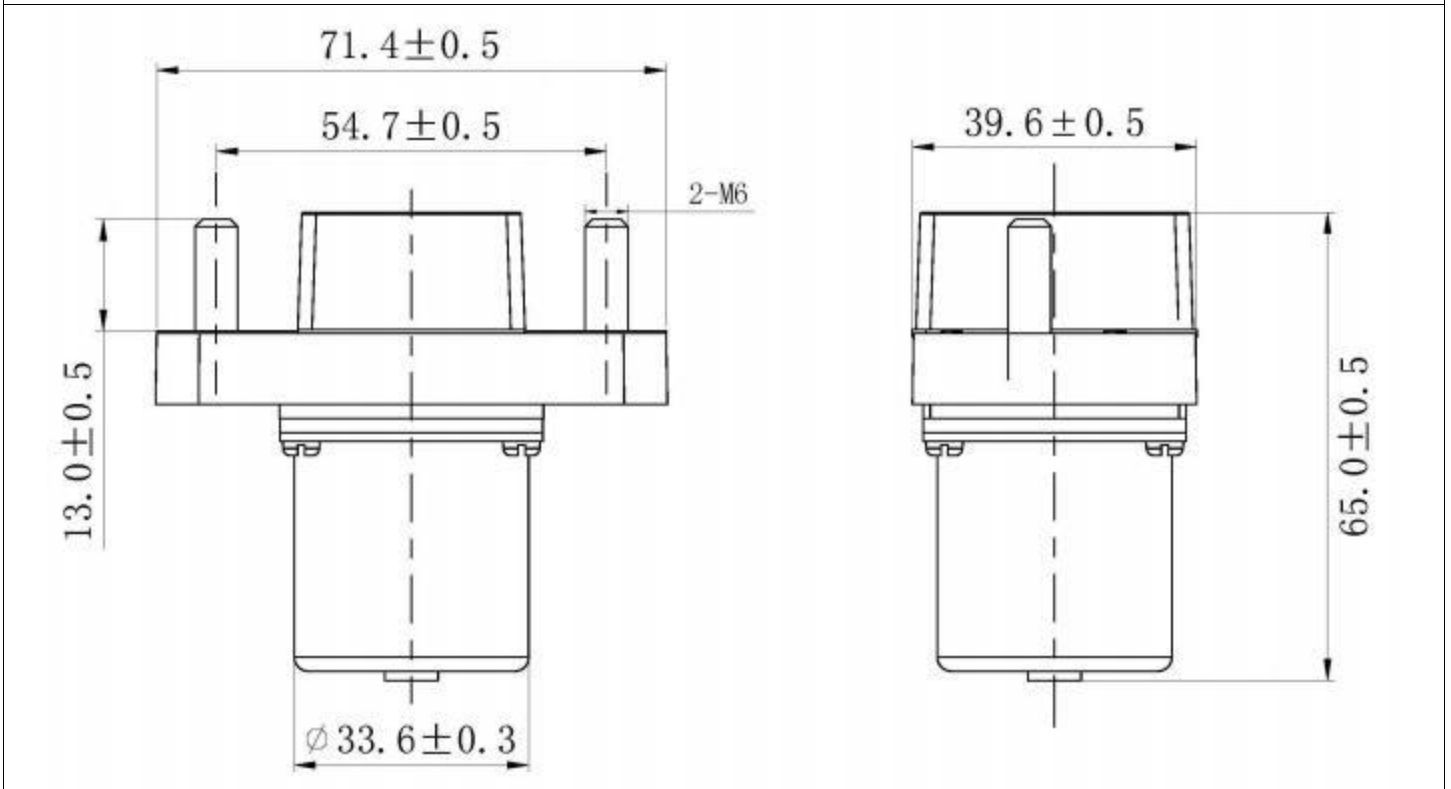

接线图

