

南京全宁电器有限公司

Nanjing QuanNing Electric Co.,Ltd

江苏省南京市江宁区东山科创园润麒路 68 号

TEL: (025) 52628081

FAX: (025) 52628051

E-MAIL: njquanning@outlook.com

CUSTOMER		MODEL NO	QNZ-400A DC72
----------	--	----------	---------------

产品外形图



ORDER DESIGNATION (订货标记)

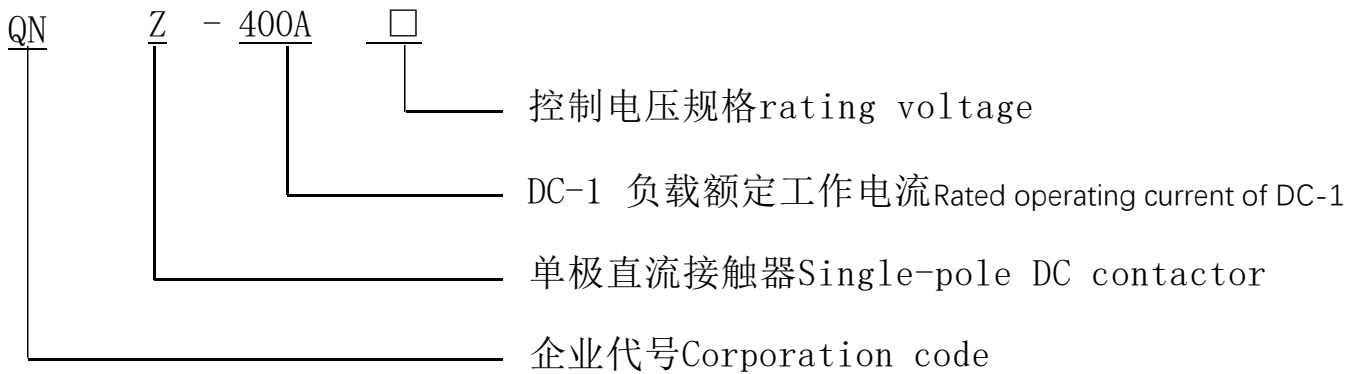

南京全宁电器有限公司

Nanjing QuanNing Electric Co.,Ltd

江苏省南京市江宁区东山科创园润麒路 68 号

TEL: (025) 52628081

FAX: (025) 52628051

E-MAIL: njquanning@outlook.com

产品应用范围: 蓄电池车辆、牵引机车、不间断电源系统、软启动

Application: Soft starter ,battery driven vehicle, traction locomotive, uninterruptible power supply syste

产品设计符合标准: IEC60947-4 , GB14048.1 , GB14048.4 , JB2286-78, JB3974-85, YD/T585-92, YD/512-92

Standards: IEC60947-4 , GB14048.1 , GB14048.4 , JB2286-78, JB3974-85, YD/T585-92, YD/512-92

产品通过的认证Certification: UL、TUV、ROHS、CCC 认证

产品技术参数Specifications:

CUSTOMER			MODEL NO	QNZ-400A DC72V	
ELECTRICAL SPECIFIC ATION					
PRIMARY					
环境温度 Ambient Temperature			-25℃~+85℃		
振动 Vibration			频率 1~50Hz 振幅 25±1mm		
海拔高度 Height above sea level			≤3000m		
触点形式 Contact Form			1NO		
额定工作电压Rated working voltage			DC48V		
额定工作电流 DC-1 Rated operating current Ie			400A		
触头接触电阻 Contact resistance mΩ			≤0.6mΩ		
约定发热电流 Conventional thermat current Ith A			400A		
操作频率 h ⁻¹ Use frequencu h ⁻¹			600		
额定绝缘电压 Insulation voltage			1500V		
介质耐压 Initial Dielectric Strength	线圈触点间 Between Contacts and Coil		3500V/1Min 无击穿或闪络现象, 且泄露电流≤5Ma 3500V/1Min No breakdown or flashover , And leakage current ≤ 5mA		
	开路触点间 Between Open Contacts		3500V/1Min 无击穿或闪络现象, 且泄露电流≤5mA 3500V/1Min No breakdown or flashover , And leakage current ≤ 5mA		
电气寿命 (DC-1) Electrical Life (DC-1)			5×10 ⁴ 次		
温升 Elevatory temperature	线圈 (额定控制电压下) Coil (Rated control voltage)		≤85K		
	接线端子 (额定工作电流下) Terminal blocks (Rated operating current)		≤70K		
	外壳Outer Shell		<70K		
漆包线magnet wire	耐温Temperature Resistance		≤180℃		
	绝缘等级Insulation grade		H 级		
	耐压 (漆层对地) Pressure resistance (paint layer against ground)		1000V/1Min 无击穿或闪络现象, 且泄露电流≤5mA 1000V/1Min No breakdown or flashover , And leakage current ≤ 5mA		

线圈参数 (在 20℃下) COLLDATE (AT 20℃)

额定电压 RATED VOLTAGE (V DC)	启动电流 Starting Current (A)	保持电流 Holding Current (A)	吸合电压范围 PULL IN CURRENT RANGE (V DC)	释放电压范围 DROP VOLTAGE RANGE (V DC)	吸合功率 PULL IN POWER (VA)
72	< 0.11	< 0.09	61.2-79.2	7.2-43.2	< 8

可根据客户要求特殊定做Specifications can be made according to customer's order.

南京全宁电器有限公司
Nanjing QuanNing Electric Co.,Ltd

江苏省南京市江宁区东山科创园润麒路 68 号

TEL: (025) 52628081

FAX: (025) 52628051

E-MAIL: njquanning@outlook.com_

CUSTOMER		MODEL NO	QNZ-400A DC72V
----------	--	----------	----------------

OVERALL AND MOUNTING DIMENSIONS (外型尺寸与安装尺寸)

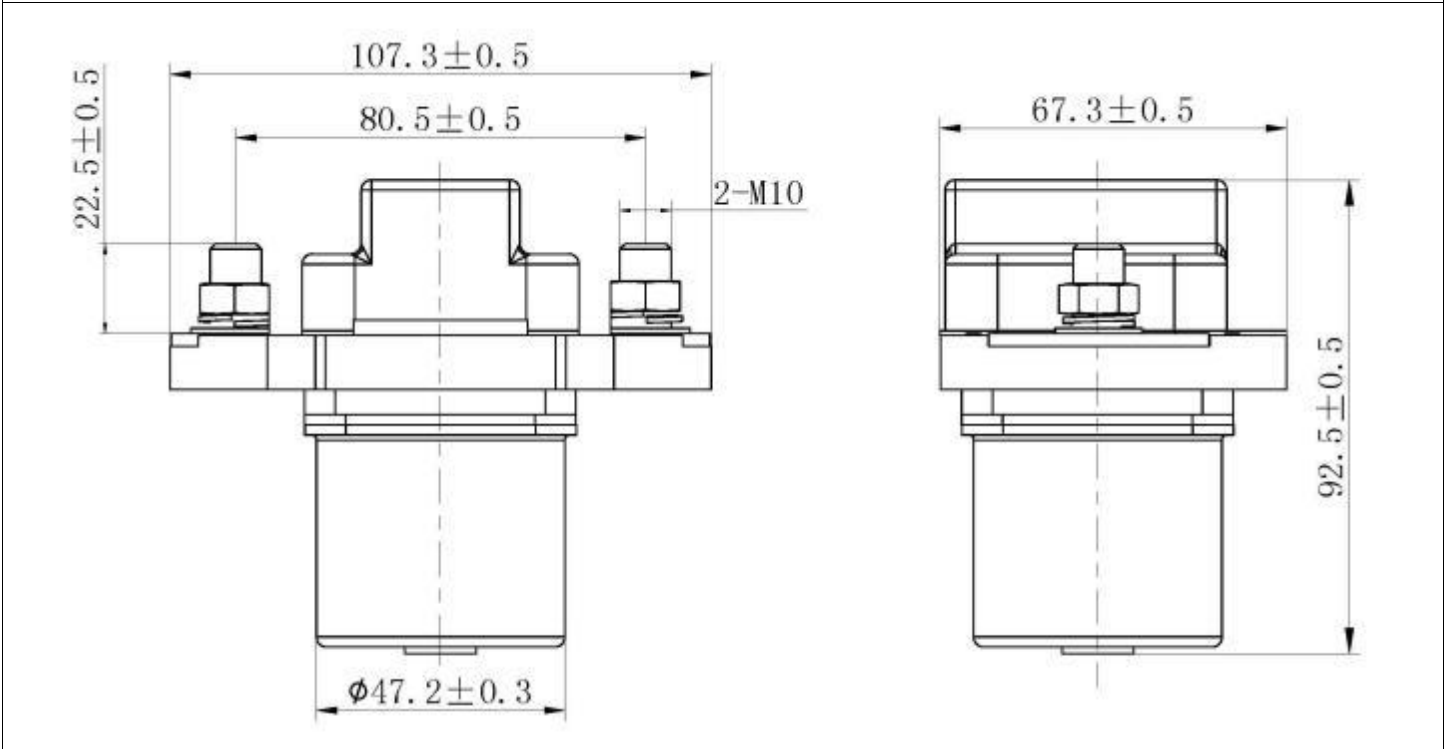

接线图

