

YVF2&YD系列低压交流异步电动机
YVF2&YD series Low-voltage
Three-phase Asynchronous Motor

产品样本
Catalogue



公司概况

Company Profile



西门子电机（中国）有限公司

西门子电机（中国）有限公司是西门子在中国的独资企业，位于江苏省仪征市，占地面积为200亩。公司主要致力于研发和生产中小型低压三相异步电动机，目前生产符合 IEC 标准的西门子品牌三相异步电动机、以及按中国标准设计的贝得品牌系列三相异步电动机。

作为西门子在全球中小型低压电机产品的重要生产基地之一，公司将坚持秉承西门子尖端技术，采用西门子特色的现代化管理模式，严格按照国际标准 ISO9001:2015 实施全面质量管理，竭诚为广大客户提供优质的产品和服务！

Siemens Standard Motors Ltd.

Siemens Standard Motors Ltd. (SSML) is a Siemens-owned company in China. With an area of 133,400 square meters, SSML is located in Yizheng City, Jiangsu Province. The company focuses on developing and producing small and medium low-voltage motors. Currently, SSML mainly produce Siemens brand low voltage AC motors according to IEC standards, and Beide brand low voltage motors designed according to China local standards.

As one of Siemens main low-voltage motor production facilities worldwide, SSML uses the knowledge and experience of more than 100 years in motor design and manufacturing, and implement comprehensive quality control according to ISO9001 2008. SSML will continuously serve customers with high quality products and good service.

公司概况

Company Profile



质量方针

- 质量从我做起,第一次把事情做对。
- 鼓励员工发现问题并勇于承担责任。
- 拒不接受不合格产品。
- 持续改进我们的流程,超越客户期望。

环境方针

西门子电机(中国)有限公司的环境、职业健康和安全方针是:

- 我们依据ISO14001:2015 和 ISO 45001-2018 标准的要求,有效建立、实施环境和职业健康安全管理体系,不断提高,持续改进。
- 我们承诺遵守环境、职业健康安全相关的法律法规,履行环境保护及职业健康安全防护职责。
- 我们致力于履行应负的社会责任和义务,合理使用资源,保护环境,加强职业健康安全管理,实现安全生产零伤害。

Quality Guideline

- Quality starts with me, Do it right in the first time.
- Encourage our employee to address problem openly and take responsibility.
- Refuse to accept defective product.
- Continuously improve our process to exceed customer's expectation.

Environmental Guideline

EHS Policy of Siemens Standard Motors Ltd. is as follows:

- We institute and implement a continuously improving management system addressing our environment, occupational health and safety in compliance with the requirements of ISO14001:2015 and ISO 45001-2018 criteria.
- We commit ourselves to abiding by the environmental, occupational health and safety laws and regulations, and fulfilling our duties in environmental protecting and occupational health safeguarding.
- We commit ourselves to the fulfillment of our social responsibility and obligation, properly harnessing resources, protecting our environment, enhancing occupational health and safety management with the ultimate goal of zero harm in our production process.

目录

Contents



公司概况	2
Company Profile	
YVF2 系列变频调速专用三相异步电动机	5
YVF2 Series Variable Speed Motors	
标准选项 — YVF2	18
Standard Options — YVF2	
YD 系列变极多速三相异步电动机	19
YD Series Change-Poles Multi-Speed Asynchronous Motors	
证书	22
Certificates	

YVF2 系列变频调速专用三相异步电动机

YVF2 Series Variable Speed Motors



额定功率: 0.55 ~ 315 kW	Rated output: 0.55 ~ 315 kW
机座号: 80 ~ 355	Frame Size: 80 ~ 355
额定电压: 380 V	Rated voltage: 380 V
冷却方式: IC416	Cooling method: IC416
防护等级: IP55	Protection degree: IP55
绝缘等级: F	Insulation class: F
环境温度: -15 ~ 40 °C	Coolant temperature: -15 ~ 40 °C
海拔高度: 不超过 1000 m	Site altitude: Up to 1000 m above sea level

概述

YVF2 系列变频调速专用三相异步电动机是一种交流、高效、节能型调速电动机，可与国内外变频器配套使用，该产品运行可靠、维护方便。电机单独装有轴流风机，在不同转速下均有较好的冷却效果。可广泛用于轻工、纺织、化工、冶金、机床行业等需要调节转速的设备中。

Introduction

YVF2 Series Variable Speed Motors are AC high efficiency, energy saving motors. It can be configured with the frequency converter from domestic and abroad. It has the characteristics with reliable operation and easy maintenance. Separate axial-flow ventilator is installed, which can guarantee a better cooling effect in different speed. YVF2 series motors can be widely applied to the equipment which need speed control in light industry, textile, chemical, metallurgy and machine tool industries etc.

安装结构型式 Construction and mounting type

结构型式Construction type	机座带底脚, 端盖无法兰 With feet and without flange on the end-shield (DE)					
安装型式Mounting type	IM B3 FS ³⁾ 80 ~ 355	IM B6 FS 80 ~ 160	IM B7 FS80 ~ 160	IM B8 FS 80 ~ 160	IM V5 ¹⁾ FS 80 ~ 160	IM V6 ²⁾ FS 80 ~ 160
示意图Diagram						
结构型式Construction type	机座不带底脚, 端盖有法兰 Without feet and with flange on the end-shield (DE)			机座带底脚, 端盖有法兰 With feet and with flange on the end-shield (DE)		
安装型式Mounting type	IM B5 FS 80 ~ 280	IM V1 ¹⁾ FS 80 ~ 355	IM V3 ²⁾ FS 80 ~ 160	IM B35 FS 80 ~ 355	IM V15 ¹⁾ FS 80 ~ 160	IM V35 ²⁾ FS 80 ~ 160
示意图Diagram						
结构型式Construction type	机座不带底脚, 端盖有标准小法兰 Without feet and with C-flange on the end-shield (DE)			机座带底脚, 端盖有标准小法兰 With feet and with C-flange on the end-shield (DE)		
安装型式Mounting type	IM B14 FS 80 ~ 112	IM V18 ¹⁾ FS 80 ~ 112	IM V19 ²⁾ FS 80 ~ 112	IM B34 FS80 ~ 112		
示意图Diagram						

¹⁾ 室外使用时推荐使用护罩;

²⁾ 当户外安装时, 推荐对电动机轴采取防护措施, 避免水直接喷射到电动机轴上。

³⁾ FS - 机座号

¹⁾ At outdoor application, the using of protective cover (Option code H00) is recommended

²⁾ At out door application the protection of shaft again jet-water is recommended

³⁾ FS-frame size

YVF2 订货号样例

Order No. example:

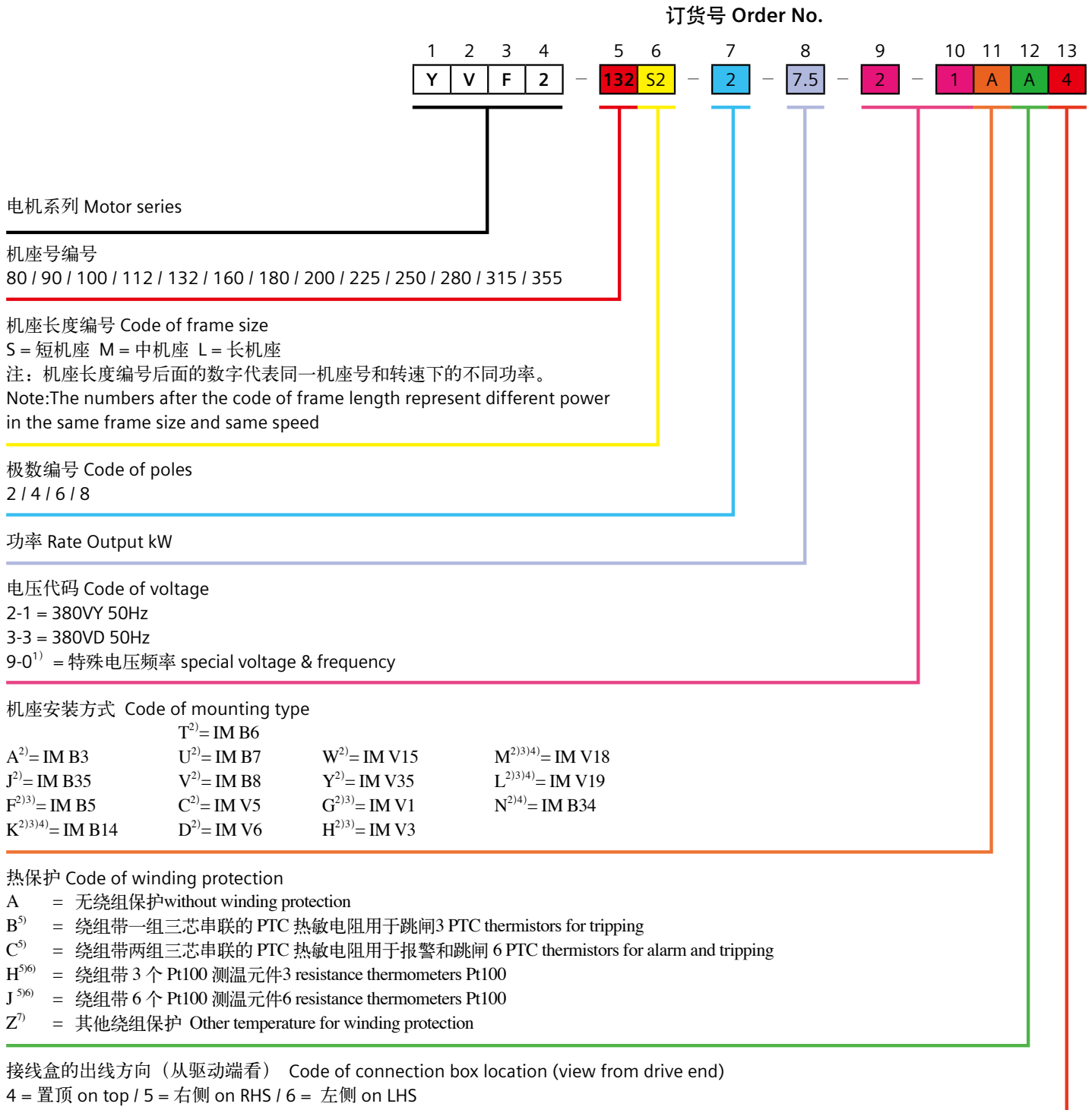

附注:

- 1) 用电压编号 90 及相应选件号来定制其它电压 (参见选件描述) ;
- 2) 铭牌上标有指定的安装结构型式;
- 3) 对于 IM B5、IM V1、IM V3、IM B14、IM V18 和 IM V19 安装结构型式电动机, 须指定电动机订货号第 16 位数字为“4”;
- 4) 只适用于 FS80 ~ 112;
- 5) 选择此选件, 接线盒将更改为铸铁壳。
- 6) 仅适用于机座号100-355。
- 7) 请向西门子另行咨询

Foot notes:

- 1) Order other voltages with voltage code 90 and the corresponding Option code (see under "Option") .
- 2) The type of mounting construction is stamped on the rating plate.
- 3) For motor with IM B5, IM V1, IM V3, IM B14, IM V18 and IM V19 construction and mounting type, the 16th digit of motor order No. must be "4";
- 4) Only for FS80 ~ 112.
- 5) Choose this option, the connection box will be changed to cast iron.
- 6) Only applicable for frame size 100-355.
- 7) Please specially consult with Siemens.

订货号样例:

变频调速专用三相异步电动机
 4 极, 5.5 kW, IM B3, 380VY 50 Hz, IP55 , 接线盒位置处于右侧, 进线孔向下 (从驱动端看)。
 电动机订货号: YVF2-132S-4-5.5-2-1AA5

Order No. example:

Variable Speed Motors
 4 pole, 5.5 kW, IM B3, 380VY 50 Hz, IP55,
 connection box at right side and cable entry at bottom (view from DE)
 Motor order code: YVF2-132S-4-5.5-2-1AA5

Y	V	F	2	-	132	S	-	4	-	5.5	-	2	-	1	A	A	5
---	---	---	---	---	-----	---	---	---	---	-----	---	---	---	---	---	---	---

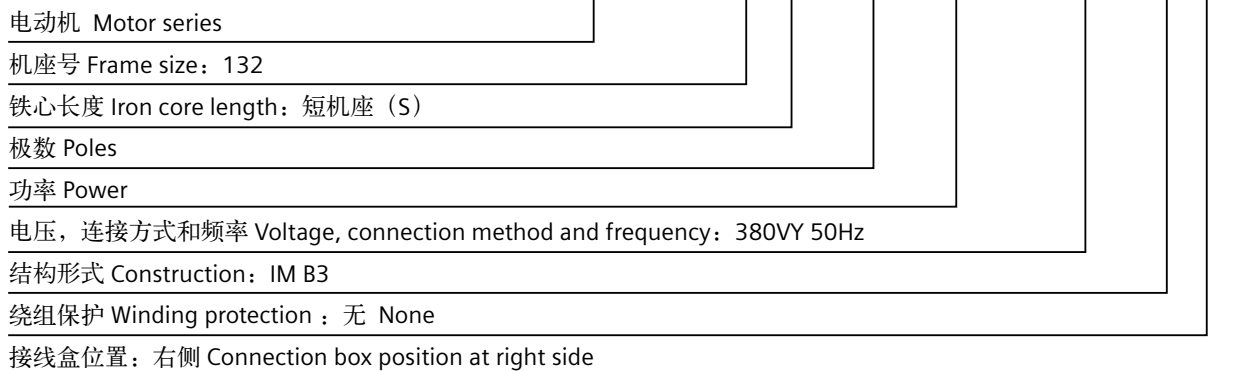

铭牌样例 Nameplate example

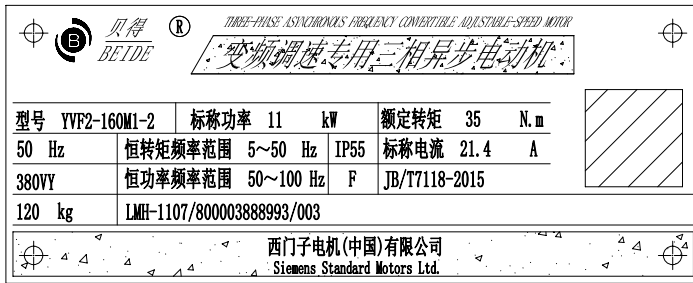

轴承系统

YVF2系列电动机标准配置深沟球轴承或角接触球轴承，这些轴承是密封的或可再润滑型的。

FS80 ~ 160 范围的 YVF2 电动机驱动端与非驱动端轴承浮动；FS180 ~ 355 电动机驱动端轴承浮动，非驱动端轴承固定。

Bearing system

YVF2 series motors are supplied with the ball bearing as standard. These bearings are either of the sealed or regreasable type.

For FS80 ~ 160, the floating bearings are assembled; for FS180 ~ 355, floating bearing at DE, and fixed bearing at NDE assembled.

轴承选配 Bearing Assignment

机座号 Frame size	极数 Pole	驱动端轴承 DE bearing	非驱动端轴承（水平安装） NDE bearing (Horizontal mounting)	非驱动端轴承（立式安装） NDE bearing (Horizontal mounting)
80	2, 4, 6	6204 2RZ C3	6204 2RZ C3	6204 2RZ C3
90	2, 4, 6	6205 2RZ C3	6205 2RZ C3	6205 2RZ C3
100	2, 4, 6	6206 2RZ C3	6206 2RZ C3	6206 2RZ C3
112	2, 4, 6	6206 2RZ C3	6206 2RZ C3	6206 2RZ C3
132	2, 4, 6, 8	6208 2RZ C3	6208 2RZ C3	6208 2RZ C3
160	2, 4, 6, 8	6309 2RZ C3	6209 2RZ C3	6209 2RZ C3
180	2, 4, 6, 8	6310 C3	6210 C3	6210 C3
200	2, 4, 6, 8	6312 C3	6212 C3	6212 C3
225	2, 4, 6, 8	6313 C3	6213 C3	6213 C3
250	2, 4, 6, 8	6314 C3	6215 C3	7215 AC
280	2, 4, 6, 8	6317 C3	6217 C3	7217 AC
315	2	6319 C3	6317 C3	7317 AC
	4, 6, 8	6319 C3	6319 C3	7319 AC
355	2	6319 C3	6319 C3	7319 AC
	4, 6, 8	6322 C3	6322 C3	7322 AC

机座号、极数与变频范围的对应关系表 Frame size、Pole & Frequency Table

机座号 Frame size	极数 Pole	恒转矩频率范围 Constant Torque	恒功率频率范围 Constant Power
FS80~180	2P	3~50	50~100
FS200~355			50~60
FS80~315	4P		50~100
FS355			50~75
FS80~FS355	6P		50~100
FS80~FS355	8P		

接线盒技术参数 Connection boxes technical data

机座号 Frame size	接线螺钉螺纹 Contact screw thread	外接电缆直径 (mm) Outer cable diameter (sealing range)	进线孔尺寸 Cable entry size
80 ~ 100	M4	10 ~ 14	M24 x 1.5
112 ~ 132	M5	13 ~ 18	M27 x 2 + M27 x 2
160 ~ 180	M5	18 ~ 25	M36 x 2 + M36 x 2
200 ~ 225	M8	22 ~ 32	M48 x 2 + M48 x 2
250	M10	37 ~ 44	M64 x 2 + M64 x 2
280	M10		
315	M12		
355	M16	38 ~ 47	M72 x 2 + M72 x 2

独立驱动风扇技术参数 Technical data for separately fan

对应电动机机座号 Motor frame size	额定电压(V) rated voltage	额定频率(Hz) Rated frequency	功率(W) Rated output	电流(A) Current	转速(r/min) Speed
80	220D/380Y	50	30	0.14/0.08	2800
90	220D/380Y	50	30	0.14/0.08	2800
100	220D/380Y	50	52	0.21/0.12	2800
112	220D/380Y	50	52	0.21/0.12	2800
132	220D/380Y	50	45	0.35/0.2	1400
160	220D/380Y	50	45	0.35/0.2	1400
180	220D/380Y	50	120	1.04/0.6	1400
200	220D/380Y	50	120	1.04/0.6	1400
225	220D/380Y	50	120	1.04/0.6	1400
250	220D/380Y	50	230	1.73/1.0	1400
280	220D/380Y	50	300	1.8/1.2	1400
315	220D/380Y	50	1100	4.33/2.5	1350
355-2, 6, 8, 355M-4P	220D/380Y	50	1100	4.33/2.5	1350
355L-4P	220D/380Y	50	2200	8.8/5.1	1410

注：风扇可以在 210 ~ 240VD/360 ~ 420VY 50Hz 电源供电下运行，也可以在 220 ~ 260VD/380 ~ 480VY 60Hz 电源供电下运行。其他电源供电，须特殊询价。

Note: The fan can be running with supply 210 ~ 240VD/360 ~ 420VY 50Hz, and also 220 ~ 260VD/380 ~ 480VY 60Hz. Other voltage supply, possible on request.

技术数据 Technical data

标称功率 Power (kW)	型号 Type	额定转矩 Rated torque (N.m)	电流 Current (A)	重量 (kG)	型号 Type	额定转矩 Rated torque (N.m)	电流 Current (A)	重量 (kG)	匹配变频器容量 Power of suited converter (kW)
0.55					YVF2-80M1-4	3.5	1.61	14.0	1
0.75	YVF2-80M1-2	2.4	1.9	13.5	YVF2-80M2-4	4.8	2.1	15.5	1
1.1	YVF2-80M2-2	3.5	2.7	15.0	YVF2-90S-4	7	2.9	20	2
1.5	YVF2-90S-2	4.8	3.5	19.0	YVF2-90L-4	9.5	3.8	23	2
2.2	YVF2-90L-2	7	4.95	23	YVF2-100L1-4	14	5.2	30	3
3	YVF2-100L-2	9.5	6.4	30	YVF2-100L2-4	19.1	6.9	33	4
4	YVF2-112M-2	12.7	8.3	37	YVF2-112M-4	25.5	9	42	6
5.5	YVF2-132S1-2	17.5	11.2	54	YVF2-132S-4	35	12	58	10
7.5	YVF2-132S2-2	23.9	14.9	59	YVF2-132M-4	47.7	16	72	10
11	YVF2-160M1-2	35	21.5	103	YVF2-160M-4	70	23	113	15
15	YVF2-160M2-2	47.7	29	113	YVF2-160L-4	97.8	29.5	129	20
18.5	YVF2-160L-2	58.9	35.5	131	YVF2-180M-4	118	37	178	30
22	YVF2-180M-2	70	42	175	YVF2-180L-4	140	43.5	200	30
30	YVF2-200L1-2	95.5	56	251	YVF2-200L-4	191	59	255	40
37	YVF2-200L2-2	118	69	261	YVF2-225S-4	236	72	299	50
45	YVF2-225M-2	143	84	305	YVF2-225M-4	287	87	325	60
55	YVF2-250M-2	175	102	410	YVF2-250M-4	350	106	420	70
75	YVF2-280S-2	239	138	510	YVF2-280S-4	478	141	545	100
90	YVF2-280M-2	287	165	580	YVF2-280M-4	573	167	650	120
110	YVF2-315S-2	350	199	795	YVF2-315S-4	700	205	815	150
132	YVF2-315M-2	420	240	920	YVF2-315M-4	840	245	1020	180
160	YVF2-315L1-2	509	285	1020	YVF2-315L1-4	1019	300	1055	210
185	YVF2-315L-2	589	330	1118	YVF2-315L-4	1180	345	1190	220
200	YVF2-315L2-2	637	355	1128	YVF2-315L2-4	1273	365	1155	270
220	YVF2-355M1-2	704	390	1490	YVF2-355M1-4	1401	405	1670	280
250	YVF2-355M2-2	796	445	1490	YVF2-355M2-4	1592	460	1670	350
280	YVF2-355L1-2	896	495	1620	YVF2-355L1-4	1783	510	1700	400
315	YVF2-355L-2	1003	560	1670	YVF2-355L2-4	2005	580	1790	450

技术数据 Technical data

标称功率 Power (kW)	型号 Type	额定转矩 Rated torque (N.m)	电流 Current (A)	重量 (kG)	型号 Type	额定转矩 Rated torque (N.m)	电流 Current (A)	重量 (kG)	匹配变频器容量 Power of suited converter (kW)
0.55	YVF2-80M2-6	5.3	1.66	16.0					1
0.75	YVF2-90S-6	7.2	2.25	20					1
1.1	YVF2-90L-6	10.5	3.2	24					2
1.5	YVF2-100L-6	14.3	4.2	31					2
2.2	YVF2-112M-6	21	6	41	YVF2-132S-8	28	7.5	72	3
3	YVF2-132S-6	28.6	7.9	54	YVF2-132M-8	38.2	9.9	70	4
4	YVF2-132M1-6	38.2	10.1	65	YVF2-160M1-8	51	11.6	105	6
5.5	YVF2-132M2-6	52.5	13.4	73	YVF2-160M2-8	70	15.1	103	10
7.5	YVF2-160M-6	71.6	17.2	115	YVF2-160L-8	95.5	20.5	127	10
11	YVF2-160L-6	105	24.5	145	YVF2-180L-8	140	26	163	15
15	YVF2-180L-6	143	31.5	183	YVF2-200L-8	191	34	233	20
18.5	YVF2-200L1-6	177	39.5	235	YVF2-225S-8	236	42	246	30
22	YVF2-200L2-6	210	46.5	252	YVF2-225M-8	280	50	286	30
30	YVF2-225M-6	287	62	320	YVF2-250M-8	382	64	355	40
37	YVF2-250M-6	353	75	400	YVF2-280S-8	471	84	427	50
45	YVF2-280S-6	430	88	483	YVF2-280M-8	573	97	485	60
55	YVF2-280M-6	525	106	550	YVF2-315S-8	700	115	665	70
75	YVF2-315S-6	716	146	790	YVF2-315M-8	955	156	815	100
90	YVF2-315M-6	859	173	920	YVF2-315L1-8	1146	182	860	120
110	YVF2-315L1-6	1050	210	1055	YVF2-315L2-8	1401	220	1010	150
132	YVF2-315L2-6	1261	250	1195	YVF2-355M1-8	1681	265	1530	180
160	YVF2-355M1-6	1528	300	1770	YVF2-355M2-8	2037	325	1650	210
185	YVF2-355M2-6	1767	350	1770	YVF2-355L1-8	2356	365	1820	220
200	YVF2-355M3-6	1910	375	1810	YVF2-355L2-8	2547	395	1930	270
220	YVF2-355L1-6	2101	415	1980					280
250	YVF2-355L2-6	2387	470	2010					350

安装及外形尺寸 Dimensions of mounting and outline

IM B3 安装结构型式 Type of construction IM B3

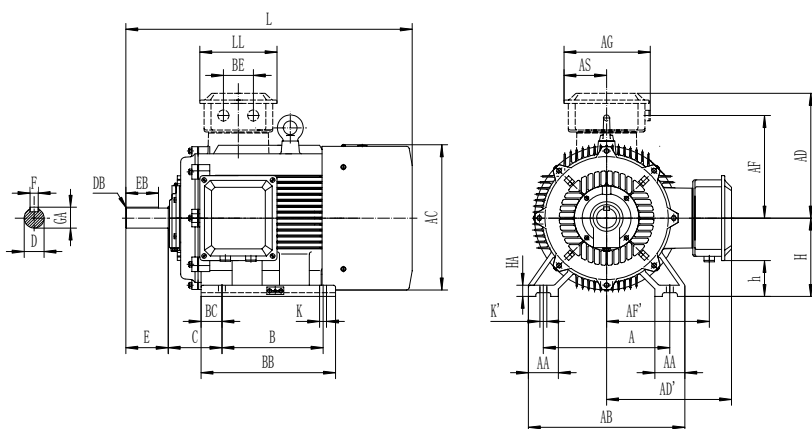

IM B35 安装结构型式 Type of construction IM B35

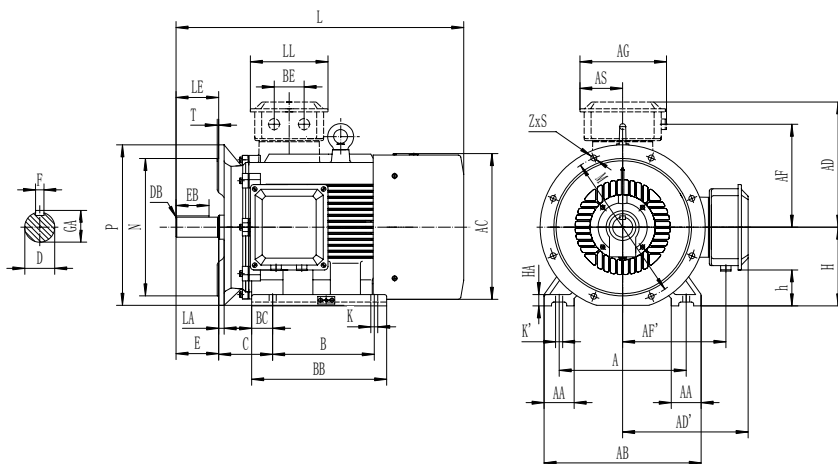

机座号 Frame size	类型 Type YVF2-	极数 pols	尺寸图依据IEC标准 Dimension designation according to IEC standards									
			A	AA	AB	AC	AD / AD'	AF / AF'	AG	AH	AS	B
80 M	80M1-□	2, 4, 6	125	34	160	161	145	107	130	-	52	100
	80M2-□		125	34	160	161	145	107	130	-	52	100
90 S	90S-□	2, 4, 6	140	36	180	175	160	116	135	-	55	100
	90L-□		140	36	180	175	160	116	135	-	55	125
100 L	100L-2	2	160	40	200	196	165	129	135	-	55	140
	100L1-4	4										
	100L-6	6										
	100L2-4	4	160	40	200	196	165	129	135	-	55	140
112 M	112M-□	2, 4, 6	190	45	226	217	193	145	152	-	64	140
132 S	132S1-2	2	216	55	262	258	203	166	152	-	64	140
	132S-□	4, 6, 8										
132 M	132S2-2	2	216	55	262	258	203	166	152	-	64	140
	132M-4	4	216	55	262	258	203	166	152	-	64	178
	132M1-6	6										
	132M-8	8										
	132M2-6	6	216	55	262	258	203	166	152	-	64	178
160 M	160M1-2	2	254	65	314	311	255	207	195	480	83	210
	160M-4	4										
160 L	160M-6	6										
	160M1-8	8										
	160M2-□	2, 8	254	65	314	311	255	207	195	480	83	210
	160L-□	2, 4, 6, 8	254	65	314	311	255	207	195	480	83	254

IM B5 以及 IM V1 安装结构型式 Type of construction IM B5 and IM V1

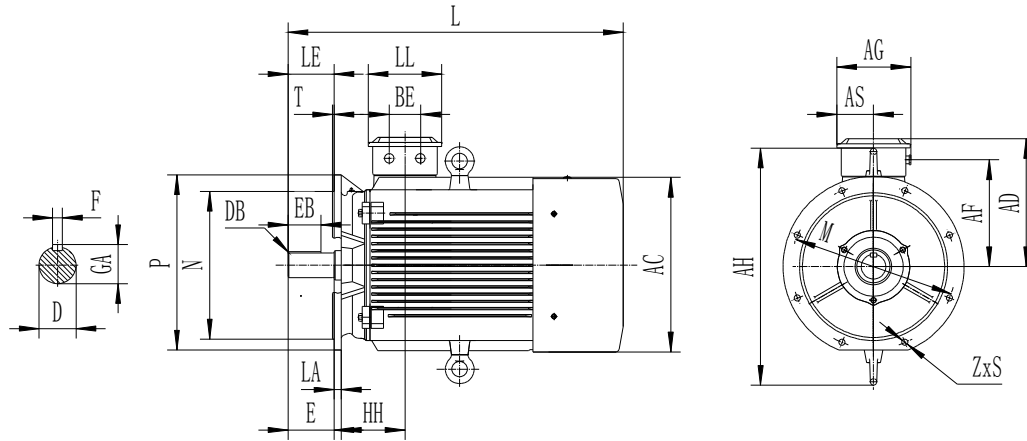

IM B14 安装结构型式 Type of construction IM B14

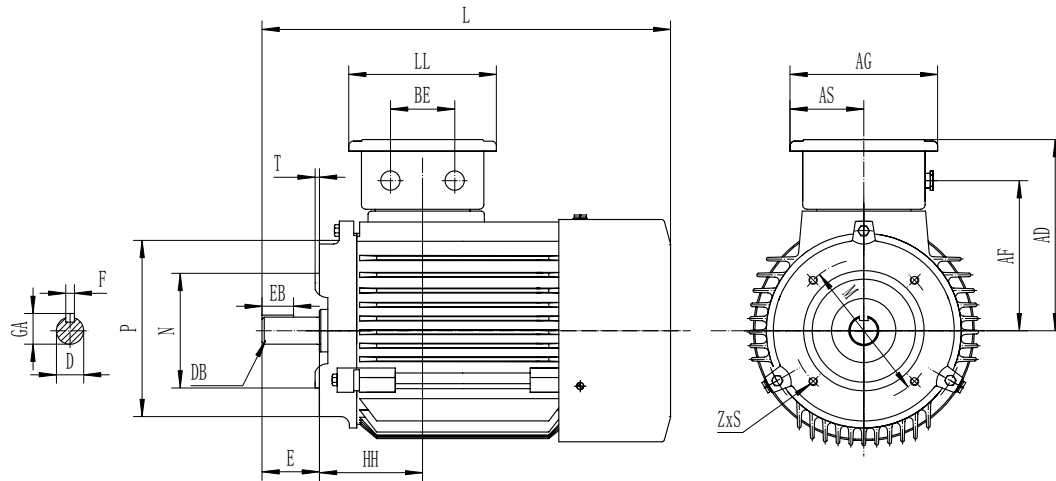

尺寸图依据IEC标准 Dimension designation according to IEC standards

驱动端轴伸直径 DE shaft extension

	BB	BC	BE	C	H	h	HA	HH	K / K'	L	LL	D	DB	E	EB	F	GA
	130	15	-	50	80	29	10	72	10	350	103	19	M6	40	22	6	21.5
	130	15	-	50	80	29	10	72	10	350	103	19	M6	40	22	6	21.5
	140	20	-	56	90	35	12	75	10	395	110	24	M8	50	32	8	27
	165	20	-	56	90	35	12	75	10	420	110	24	M8	50	32	8	27
	188	24	-	63	100	45	14	77	12	455	110	28	M10	60	40	8	31
	188	24	-	63	100	45	14	77	12	455	110	28	M10	60	40	8	31
	180	20	42	70	112	48	15	87	12	480	119	28	M10	60	40	8	31
	186	23	42	89	132	68	18	99	12	545	119	38	M12	80	56	10	41
	186	23	42	89	132	68	18	99	12	545	119	38	M12	80	56	10	41
	224	23	42	89	132	68	18	99	12	585	119	38	M12	80	56	10	41
	224	23	42	89	132	68	18	99	12	585	119	38	M12	80	56	10	41
	260	25	60	108	160	77	20	150	15	660	157	42	M16	110	80	12	45
	260	25	60	108	160	77	20	150	15	660	157	42	M16	110	80	12	45
	320	25	60	108	160	77	20	150	15	720	157	42	M16	110	80	12	45
	304									705							

安装及外形尺寸 Dimensions of mounting and outline

机座号 Frame size	类型 Type YVF2-	极数 pols	尺寸图依据IEC标准 Dimension designation according to IEC standards									
			A	AA	AB	AC	AD / AD'	AF / AF'	AG	AH	AS	B
180M 180L	180M-□	2,4	279	70	349	356	275	223	195	515	83	241
	180L-□	4,6 8	279	70	349	356	275	223	195	515	83	279
200L	200L1-2	2	318	70	388	398	310	248	255	575	107	305
	200L-4	4										
	200L1-6	6										
	200L2-2	2	318	70	388	398	310	248	255	575	107	305
	200L2-6 200L-8	6 8										
225S	225S-4	4	356	75	431	428	325	257	255	605	107	286
	225S-8	8										
225M	225M-2	2	356	75	431	428	325	257	255	605	107	311
	225M-□	4,6	356	75	431	428	325	257	255	605	107	311
	225M-8	8	356	75	431	428	325	257	255	605	107	311
250M	250M-2	2	406	80	484	475	360	292	285	670	124	349
	250M-□	4,6	406	80	484	475	360	292	285	670	124	349
	250M-8	8										
280S	280S-2	2	457	85	542	530	395	322	285	755	124	368
	280S-□	4,6	457	85	542	530	395	322	285	755	124	368
	280S-8	8										
280M	280M-2	2	457	85	542	530	395	322	285	755	124	419
	280M-□	4,6	457	85	542	530	395	322	285	755	124	419
	280M-8	8	457	85	542	530	395	322	285	755	124	419
315S	315S-2	2	508	120	628	581	505	413	370	920	171	406
	315S-□	4,6										
315M	315S-8	8	508	120	628	581	505	413	370	920	171	406
	315M-2	2	508	120	628	581	505	413	370	920	171	457/508
315L	315M-□	4,6										
	315M-8	8	508	120	628	581	505	413	370	920	171	457/508
	315L1-2	2	508	120	628	581	505	413	370	920	171	457/508
	315L-2	2										
	315L2-2	2										
	315L1-4	4	508	120	628	581	505	413	370	920	171	457/508
	315L-4	4										
	315L2-4	4										
	315L1-6	6										
	315L2-6	6										
355M	355M1-2	2	610	120	730	698	625	517	454	1145	181	560/630
	355M1-□	4,6,8	610	120	730	698	625	517	454	1145	181	560/630
	355M2-2	2	610	120	730	698	625	517	454	1145	181	560/630
	355M2-□	4,6										
	355M2-8	8	610	120	730	698	625	517	454	1145	181	560/630
	355M3-6	6	610	120	730	698	625	517	454	1145	181	560/630
	355L1-2	2	610	120	730	698	625	517	454	1145	181	560/630
	355L1-□	4,6										
	355L1-8	8	610	120	730	698	625	517	454	1145	181	560/630
	355L-2	2	610	120	730	698	625	517	454	1145	181	560/630
355L	355L2-□	4,6	610	120	730	698	625	517	454	1145	181	560/630
	355L2-8	8										

尺寸图依据IEC标准 Dimension designation according to IEC standards											驱动端轴伸直径 DE shaft extensiion						
	BB	BC	BE	C	H	h	HA	HH	K / K'	L	LL	D	DB	E	EB	F	GA
	345	35	60	121	180	97	22	161	15	785	157	48	M16	110	80	14	51.5
	385	35	60	121	180	97	22	161	15	825	157	48	M16	110	80	14	51.5
	344									785							
	412	32	72	133	200	94	25	186	19	880	194	55	M20	110	80	16	59
	412	32	72	133	200	94	25	186	19	880	194	55	M20	110	80	16	59
	379									845							
	366	45	72	149	225	119	28	189	19	880	194	60	M20	140	100	18	64
	405	45	72	149	225	119	28	189	19	880	194	60	M20	140	100	18	64
	405	45	72	149	225	119	28	189	19	905	194	55	M20	110	80	16	59
	391	45	72	149	225	119	28	189	19	935	194	60	M20	140	100	18	64
	391	45	72	149	225	119	28	189	19	905	194	60	M20	140	100	18	64
	460	40	80	168	250	126	30	222	24	1020	224	60	M20	140	100	18	64
	460	40	80	168	250	126	30	222	24	1020	224	65	M20	140	100	18	69
	425									970							
	485	74	80	190	280	156	35	216	24	1090	224	65	M20	140	100	18	69
	485	74	80	190	280	156	35	216	24	1090	224	75	M20	140	100	20	79
										1075							
	536	74	80	190	280	156	35	216	24	1140	224	65	M20	140	100	18	69
	536	74	80	190	280	156	35	216	24	1140	224	75	M20	140	100	20	79
	536	74	80	190	280	156	35	216	24	1125	224	75	M20	140	100	20	79
	540	84	120	216	315	155	45	257	28	1320	280	65	M20	140	100	18	69
										1350		80		170	130	22	85
	540	84	120	216	315	155	45	257	28	1300	280	80	M20	170	130	22	85
	680	84	120	216	315	155	45	257	28	1550	280	65	M20	140	100	18	69
										1580		80		170	130	22	85
	680	84	120	216	315	155	45	257	28	1480	280	80	M20	170	130	22	85
	680	84	120	216	315	155	45	257	28	1550	280	65	M20	140	100	18	69
	680	84	120	216	315	155	45	257	28	1580	280	80	M20	170	130	22	85
	680	84	120	216	315	155	45	257	28	1480	280	80	M20	170	130	22	85
	750	68	125	254	355	136	53	281	28	1640	400	75	M20	140	125	20	79.5
	750	68	125	254	355	136	53	281	28	1670	400	95	M24	170	140	25	100
	750	68	125	254	355	136	53	281	28	1640	400	75	M20	140	125	20	79.5
										1670		95	M24	170	140	25	100
	750	68	125	254	355	136	53	281	28	1670	400	95	M24	170	140	25	100
	750	68	125	254	355	136	53	281	28	1670	400	95	M24	170	140	25	100
	750	68	125	254	355	136	53	281	28	1640	400	75	M20	140	125	20	79.5
										1670/1770 ¹⁾		95	M24	170	140	25	100
	750	68	125	254	355	136	53	281	28	1670	400	95	M24	170	140	25	100
	750	68	125	254	355	136	53	281	28	1640	400	75	M20	140	125	20	79.5
	750	68	125	254	355	136	53	281	28	1670/1770 ¹⁾	400	95	M24	170	140	25	100

¹⁾ 此尺寸适用于4极电机。The dimension suitable for 4P motor.

安装及外形尺寸 Dimensions of mounting and outline

法兰尺寸 Flange dimension

IM B5、IM B35、IM V1、IM V3 安装结构型式 Type of construction IM B5, IM B35, IM V1, IM V3

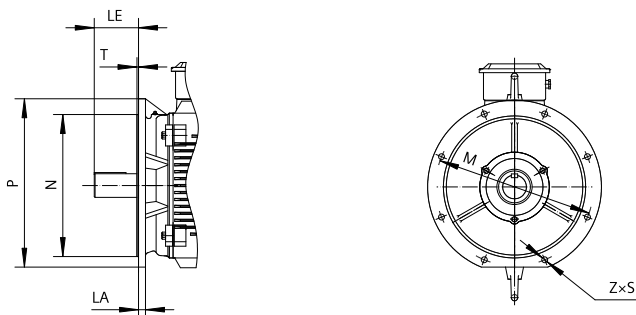

机座号 Frame size	安装结构形式 Type of construction	法兰带通孔 (FF / A) / 法兰带内螺纹孔 (FT / C)
		按 DIN / EN 50 347 标准 According to DIN EN 50347
80	IM B5, IM B35, IM V1, IM V3	FF 165
	IM B14, IM V18, IM V19	FT 100
90	IM B5, IM B35, IM V1, IM V3	FF 165
	IM B14, IM V18, IM V19	FT 115
100	IM B5, IM B35, IM V1, IM V3	FF 215
	IM B14, IM V18, IM V19	FT 130
112	IM B5, IM B35, IM V1, IM V3	FF 215
	IM B14, IM V18, IM V19	FT 130
132	IM B5, IM B35, IM V1, IM V3	FF 265
160	IM B5, IM B35, IM V1, IM V3	FF 300
180	IM B5, IM B35, IM V1, IM V3	FF 300
200	IM B5, IM B35, IM V1, IM V3	FF 350
225	IM B5, IM B35, IM V1, IM V3	FF 400
250	IM B5, IM B35, IM V1, IM V3	FF 500
280	IM B5, IM B35, IM V1, IM V3	FF 500
315	IM B5, IM B35, IM V1, IM V3	FF 600
355	IM B5, IM B35, IM V1, IM V3	FF 740

法兰尺寸 Flange dimension

IM B14、IM V18、IM V19 安装结构型式 Type of construction IM B14, IM V18, IM V19

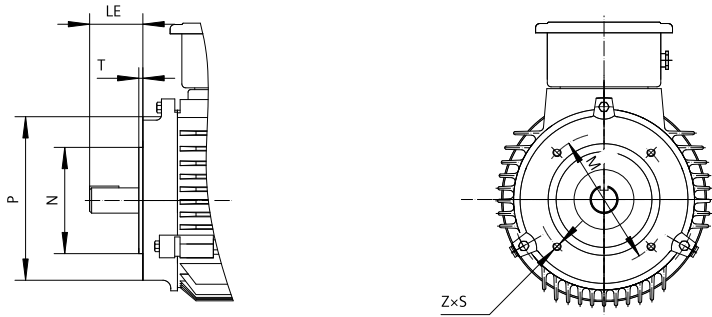

尺寸图依据 Dimension designation according to IEC standards

	LA	LE	M	N	P	S	T	Z
12		40	165	130	200	12	3.5	4
—		40	100	80	120	M 6	3	4
12		50	165	130	200	12	3.5	4
—		50	115	95	140	M 8	3	4
13		60	215	180	250	14.5	4	4
—		60	130	110	160	M 8	3.5	4
14		60	215	180	250	14.5	4	4
—		60	130	110	160	M 8	3.5	4
14		80	265	230	300	14.5	4	4
14		110	300	250	350	18.5	5	4
15		110	300	250	350	18.5	5	4
17		110	350	300	400	18.5	5	4
20		110 / 140	400	350	450	18.5	5	8
22		140	500	450	550	18.5	5	8
22		140	500	450	550	18.5	5	8
22		140 / 170	600	550	660	24	6	8
25		140 / 170	740	680	800	24	6	8

标准选件 — YVF2

Standard Options – YVF2

选件号 Option Code	描述 Option Code	应用范围 Application Scope
X658	415VY 50Hz 50Hz 功率输出 50Hz output	FS80~250
X662	380VY 60Hz 50Hz 功率输出 50Hz output	FS80~250
Q72	轴承装两个PT100测温元件 Installation of 2 PT 100 screw-in resistance thermometers (basic circuit) for rolling-contact bearings	FS180~355
Q04 ¹⁾	绕组带220V防潮加热带 Anti-condensation heater for 220V	FS80~355
R10 ²⁾	接线盒旋转90度, 进线方向为驱动端方向 Rotation of terminal box by 90 ° , inserted from drive end	FS80~355
R11 ³⁾	接线盒旋转90度, 进线方向为非驱动端方向 Rotation of terminal box by 90 ° , inserted from non-drive end	FS80~355
R12	接线盒旋转180度 Rotation of terminal box by 180 °	FS80~355
M12	英文铭牌 English Nameplate	FS80~355
P80 ⁴⁾	全圆法兰 Round flange	FS80~315
X77	光整机 Turning flange	FS80~315
S01	不喷外观漆 Unpainted	FS80~355
L80	SKF轴承 SKF bearings	FS80~355
W02	NSK轴承 NSK bearings	FS80~355
H00	电动机带防护罩 Motor with protective cover	FS80~355

¹⁾ 选择此选件, 接线盒将更改为铸铁壳

²⁾ 不适用 FS80-100 法兰安装电机

³⁾ 不适用于顶出线

⁴⁾ 对于机座号为180、200、225和280的电动机不适用, 这些机座号的电动机标配的法兰为全圆法兰

¹⁾ When choose these options, the connection boxes will be changed to cast iron shell

²⁾ Not applicable to the FS80~100 flange mounted motors

³⁾ Not applicable to the outlet on top

⁴⁾ Not applicable to the FS180、200、225 and 280 motors, these motors include the full circle flange

选件号 Option Code	描述 Option Code	应用范围 Application Scope
L23	再润滑装置 Regreasing device	FS100~250
L81	其他进口品牌轴承 Other import brand bearing	FS80~355
X07	铸铁接线盒 Cast iron connection box	FS80~355
F90	风机电机（无风扇和风扇罩，非驱动端全封闭） Fan motor (no fan cover, NDE fully enclosed)	FS80~355
B80	出厂检验报告 Acceptance test certificate 3.1 in accordance with EN 10204	FS80~355
N01	温度等级 155 (F)，使用 155 (F)，带有服务系数 (SF1.15) Temperature class 155 (F), used according to 155 (F), with service factor (SF1.15)	FS80~355
B90	包装（FS80~132电动机采用纸箱包装，FS160~355电动机采用木箱包装） Packing(FS80~132 motors adopt the carton packaging, FS160~355 motors adopt the wooden cases packaging)	FS80~355
B12	出口包装 Export packing	FS80~355
X50	安装欧姆龙编码器（E6B2-CWZ6C）和独立驱动风扇 Install OMRON encoder (E6B2-CWZ6C-1024)and independent drive fan	FS80~355

YD 系列变极多速三相异步电动机

YD Series Change-Poles Multi-Speed Asynchronous Motors



机座号: 80 ~ 280	Frame size: 80 ~ 280
额定电压: 380 V	Rated voltage: 380 V
额定频率: 50 Hz	Rated frequency: 50 Hz
冷却方式: IC411	Cooling method: IC411
防护等级: IP54	Protection degree: IP54
绝缘等级: F 级	Insulation class: F
环境温度: -15 ~ 40 °C	Coolant temperature: -15 ~ 40 °C
海拔高度: 不超过 1000 m	Site altitude: Up to 1000 m above sea level

概述

YD 系列变极多速三相异步电动机，适用于需要逐级调速的各种传动机构。

Introduction

YD series pole-changing multi-speed three-phase asynchronous motors can apply to various transmission mechanism which need control speed step by step.

安装型式 Mounting type

示意图 Diagram												
安装型式 (IM) Mounting type (IM)	B3	B5	B35	V1	V3	V5	V6	B6	B7	B8	V15	V36
机座号 Motor size	80 ~ 280	80 ~ 225	80 ~ 280	80 ~ 280	80 ~ 160							

规格表 Specification table

型号 Type	同步转速 Synchronous speed (r/min)			
	1500/3000	1000/1500	750/1500	500/1000
	极数 poles			
	4/2	6/4	8/4	12/6
功率 Power (kW)				
YD801	0.45/0.55			
YD802	0.55/0.75			
YD90S	0.85/1.1	0.65/0.85		
YD90L	1.3/1.8	0.85/1.1	0.45/0.75	
YD100L1	2/2.4	1.3/1.8	0.85/1.5	
YD100L2	2.4/3	1.5/2.2		
YD112M	3.3/4	2.2/2.8	1.5/2.4	
YD132S	4.5/5.5	3/4	2.2/3.3	
YD132M1	6.5/8	4/5.5	3/4.5	
YD132M2				
YD160M	9/11	6.5/8	5/7.5	2.6/5
YD160L	11/14	9/11	7/11	3.7/7
YD180M	15/18.5	11/14		
YD180L	18.5/22	13/16	11/17	5.5/10
YD200L1	26/30	18.5/22	14/22	7.5/13
YD200L2			17/26	9/15
YD225S	32/37	22/28		
YD225M	37/45	26/32	24/34	12/20
YD250M	45/52	32/42	30/42	15/24
YD280S		42/55	40/55	20/30
YD280M		55/67	47/67	24/37

YD 订货号样例

Order No. example:

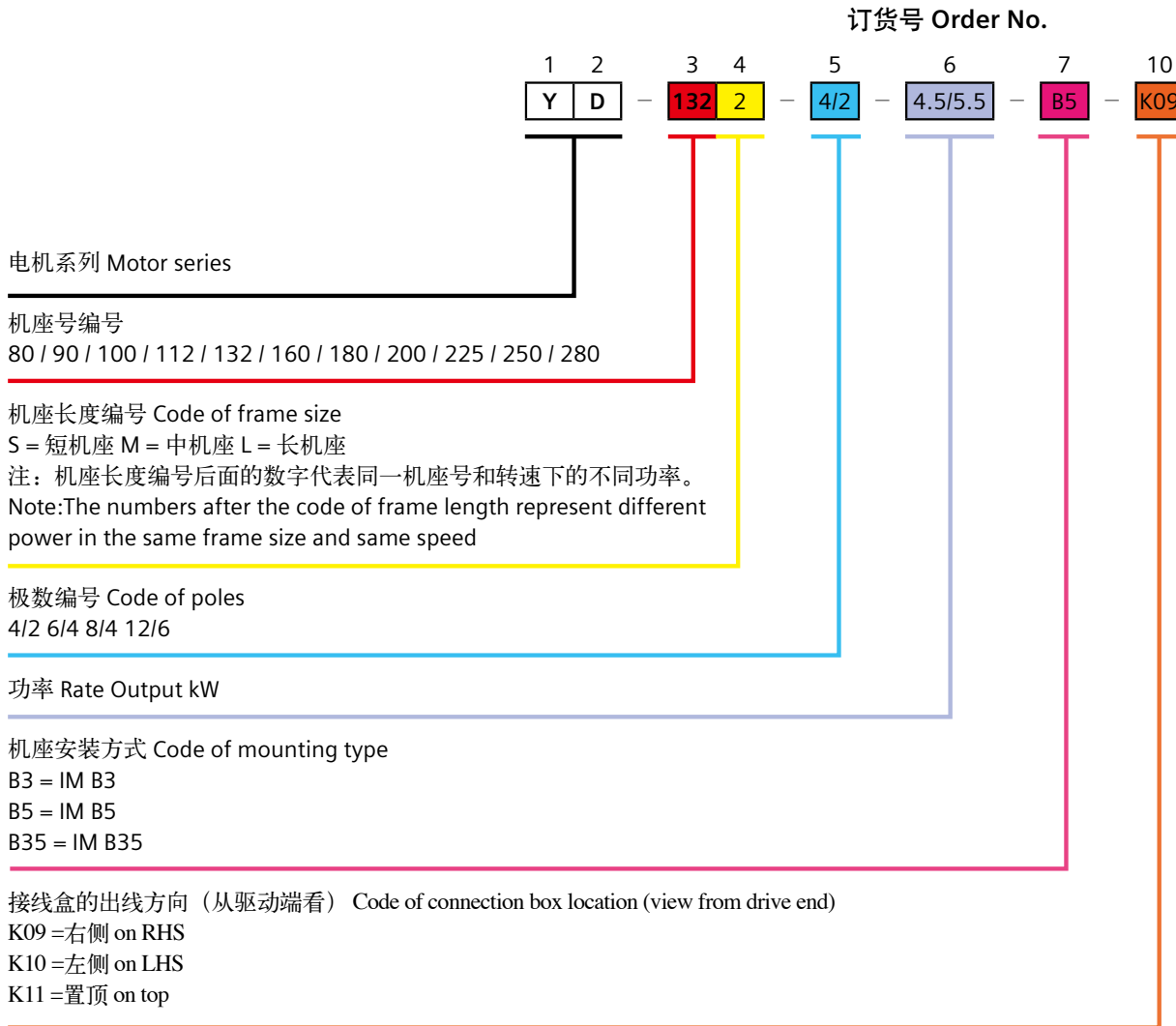

安装及外形尺寸

Dimensions of mounting and Outline

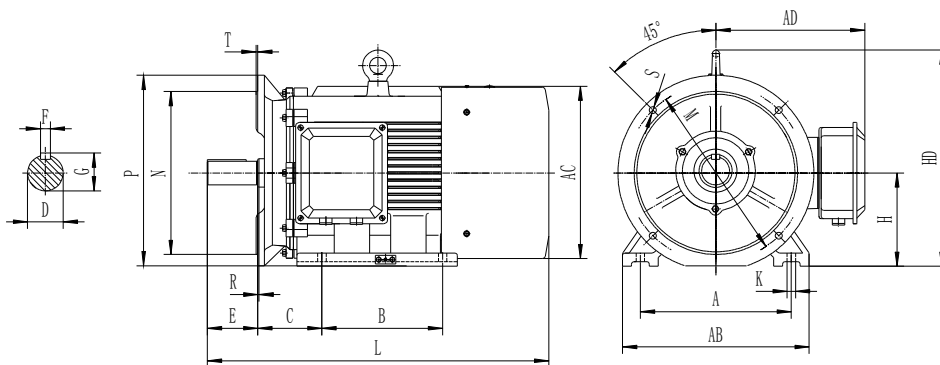

注:

1. 图为 B35 型图样，机座带底脚，端盖上有凸缘。
2. B3 型机座带底脚，端盖上无凸缘，无尺寸 M、N、P、R、S、T。
3. B5 型机座无底脚，端盖上有凸缘，无尺寸 A、B、C、AB。
4. 机座号：225~280 电机凸缘安装孔 S 为 8 孔均布。
5. R 为凸缘配合面至轴伸肩的距离。

Note:

1. The drawing is B35 type. There have housing feet and flange on end shield.
2. B3 type motors have frame feet but no flange, the dimensions have no M、N、P、R、S、T。
3. B5 type motors have flange but no frame feet, the dimensions have no A、B、C、AB。
4. There are eight symmetrical distributed holes for flange mounting on the FS225 ~ 355 motors.
5. R is the distance from the flange to the drive shaft end.

机座号 Motor size	安装尺寸 (mm) Mounting Dimensions															外形尺寸 (mm) Outline Dimensions				
	H	A	B	C	D	E	F	G	K	M	N	P	R	S	T	AB	AC	AD	HD	L
80	80	125	100	50	19	40	6	15.5	10	165	130	200	0	12	3.5	165	175	150	175	290
90S	90	140	100	56	24	50	8	20	10	165	130	200	0	12	3.5	180	195	160	195	315
90L	90	140	125	56	24	50	8	20	10	165	130	200	0	12	3.5	180	195	160	195	340
100L	100	160	140	63	28	60	8	24	12	215	180	250	0	15	4	205	215	180	245	380
112M	112	190	140	70	28	60	8	24	12	215	180	250	0	15	4	245	240	190	265	400
132S	132	216	140	89	38	80	10	33	12	265	230	300	0	15	4	280	275	210	315	475
132M	132	216	178	89	38	80	10	33	12	265	230	300	0	15	4	280	275	210	315	515
160M	160	254	210	108	42	110	12	37	15	300	250	350	0	19	5	330	335	265	385	610
160L	160	254	254	108	42	110	12	37	15	300	250	350	0	19	5	330	335	265	385	655
180M	180	279	241	121	48	110	14	42.5	15	300	250	350	0	19	5	355	380	285	430	670
180L	180	279	279	121	48	110	14	42.5	15	300	250	350	0	19	5	355	380	285	430	710
200L	200	318	305	133	55	110	16	49	19	350	300	400	0	19	5	395	420	315	475	775
225S	225	356	286	149	60	140	18	53	19	400	350	450	0	19	5	435	475	345	530	820
225M	225	356	311	149	60	140	18	53	19	400	350	450	0	19	5	435	475	345	530	845
250M	250	406	349	168	65	140	18	58	24	500	450	550	0	19	5	490	515	385	575	930
280S	280	457	368	190	75	140	20	67.5	24	500	450	550	0	19	5	550	585	410	640	1000
280M	280	457	419	190	75	140	20	67.5	24	500	450	550	0	19	5	550	585	410	640	1050

证书 Certificates



西门子电机（中国）有限公司

地址:江苏省仪征市汽车工业园众鑫路99号

电话:+86 514 85718108

传真:+86 514 85718083

邮编:211400

邮箱:beide-motor.ssml@siemens.com

网址:www.beide-motor.cn

订货号: E20001-A-0214-C600-X-5D00
664-SH902076-07125

西门子电机（中国）有限公司版权所有
如有改动 恕不事先通知。