

Modular UPS User Manual

(20-300KVA)

Contents

1. Safety	2
1.1 Safety notes	2
1.2 Symbols used in this guide	2
2. Main Features	3
2.1 Summarization	3
2.2 Functions and Features	3
2.3 Model description	4
3. Installation	5
3.1 Unpack checking	5
3.2 The appearance of the product	5
3.3 UPS module appearance	9
3.4 Installation notes	10
3.5 External Protective Devices	11
3.6 Power Cables	12
3.7 Power cable connect	14
3.9 Battery connection	15
3.10 Online UPS Modules Replacement	16
3.11 UPS Multi—Module Installation	17
3.11.1 Cabinet installation	17
3.11.2 Parallel cable installation	18
3.12 LBS installation (optional)	18
3.12.1 LCD setting	18
3.12.2 LBS cable installation	18
3.12.3 UPS installation	19
4. Operation	20
4.1 Operation Modes	20
4.2 Turn on/off UPS	22
4.2.1 Restart procedure	22
4.2.2 Test procedure	23
4.2.3 Cold start procedure	23
4.2.4 MAINTENANCE BYPASS	24
4.2.5 Shut down procedure	24
4.2.6 Startup procedure for parallel system	25
4.3 The Display	25
4.4 Display Messages/Troubleshooting	25
4.5 Options	27
Appendix 1 Specifications	29
Appendix 2 Problems and Solution	30
Appendix 3 CAN communication port definition	32
Appendix 4 RS485 communication port definition	33
Appendix 5 COM communication port definition	34
Appendix 6 LBS port definition	35
Appendix 7 REPO instruction	36

1. Safety

Important safety instructions – Save these instructions

There exists dangerous voltage and high temperature inside the UPS. During the installation, operation and maintenance, please abide the local safety instructions and relative laws, otherwise it will result in personnel injury or equipment damage. Safety instructions in this manual act as a supplementary for the local safety instructions. Our company will not assume the liability that caused by disobeying safety instructions.

1.1 Safety notes

1. Even no connection with utility power, 220/230/240VAC voltage may still exist at UPS outlet!
2. For the sake of human being safety, please well earth the UPS before starting it.
3. Don't open or damage battery, for the liquid spilled from the battery is strongly poisonous and do harmful to body!
4. Please avoid short circuit between anode and cathode of battery, otherwise, it will cause spark or fire!
5. Don't disassemble the UPS cover, or there may be an electric shock!
6. Check if there exists high voltage before touching the battery
7. Working environment and storage way will affect the lifetime and reliability of the UPS. Avoid the UPS from working under following environment for long time
 - ◆ Area where the humidity and temperature is out of the specified range (temperature 0 to 40°C, relative humidity 5%-95%)
 - ◆ Direct sunlight or location nearby heat
 - ◆ Vibration Area with possibility to get the UPS crashed.
 - ◆ Area with erosive gas, flammable gas, excessive dust, etc
8. Keep ventilations in good conditions otherwise the components inside the UPS will be over-heated which may affect the life of the UPS.

1.2 Symbols used in this guide



WARNING!

Risk of electric shock



CAUTION!

Read this information to avoid equipment damage

2. Main Features

2.1 Summarization

Our UPS is a kind of three-in- three -out high frequency online UPS, it provides 20~300kVA. The products are modularized and adopt the N+X redundancy. It can flexibly increase the number of the UPS modules according to the load capacity which is convenient for flexible allocation and gradually investment.

The UPS can solve most of the power supply problems, such as blackout, over-voltage, under-voltage, voltage sudden drop, oscillating of decreasing extent, high voltage pulse, voltage fluctuation, surge, inrush current, harmonic distortion (THD), noise interference, frequency fluctuation, etc..

This UPS can be applied to different applications from computer device, automatic equipment, communication system to industry equipment

2.2 Functions and Features

◆Digital control

◆19-inch standard cabinet

1.35-meter and 2-meter high cabinets are provided according to the user's requirement.

◆Modularized design

◆High power-density design

The height of the single module is 2U, each module is 20kVA/25kVA/30kVA.

◆N+X parallel redundancy

This series UPS adopts N+X parallel redundancy design, user can set different redundancy according to the importance of the load. While the redundancy modules are set more than two, the availability of UPS system will achieve 99.999%, which may satisfy the required reliability of the critical load connected. Through LCD display setting, you may configure the required quantity of the redundancy unit. When the load connected is over the number of the redundancy, the UPS will alert right away. The design of the MTBF (Meantime before Failure) is up to 250,000 hours.

This series can set the number of redundancy modules. When the load exceeds the redundancy setting, the UPS can still work normally and simultaneously send out corresponding warning as long as the load doesn't exceed the total capacity of modules.

◆Parallel redundant control system

◆Optimizing distributed convergence for the cabinet

◆Centralized bypass

◆Common Battery

◆Automatic charge current adjustment according to battery capacity connected.

◆3-Stage Intelligent charging

◆Touch-screen 7inch LCD display

◆Remote monitoring via SNMP

◆Optional Accessories available such as Isolation transformer, distribution Panel, SNMP Card,

Relay Contact Board, etc...

◆Equip with Maintenance Bypass Switch for easy maintenance purpose.

◆Superior MTTR (Meantime to repair) & Short shutdown time in maintenance

◆Centralized monitoring module is also available

- ◆ EPO and REPO function

2.3 Model description

This document describes the following UPS models:

- ◆ 60/75/90kVA(with 3pcs modules)

The models provide 3 configurations: 60 kVA, 75 kVA and 90kVA.

- ◆ 100/125/150kVA(5pcs modules)

The models provide 3 configurations: 100 kVA, 125kVA and 150 kVA.

- ◆ 200/250/300kVA(10pcs modules)

The models provide 3 configurations: 200 kVA, 250 kVA and 300 kVA.

- * **Standard configuration : cabinet only with maintenance bypass switch**
- * **Full configuration : cabinet with mains, bypass, maintenance and output switch**

3. Installation

3.1 Unpack checking

1. Don't lean the UPS when moving it out from the packaging
2. Check the appearance to see if the UPS is damaged or not during the transportation, do not switch on the UPS if any damage found. Please contact the dealer right away.
3. Check the accessories according to the packing list and contact the dealer in case of missing parts.

3.2 The appearance of the product

60 - 150kVA cabinet

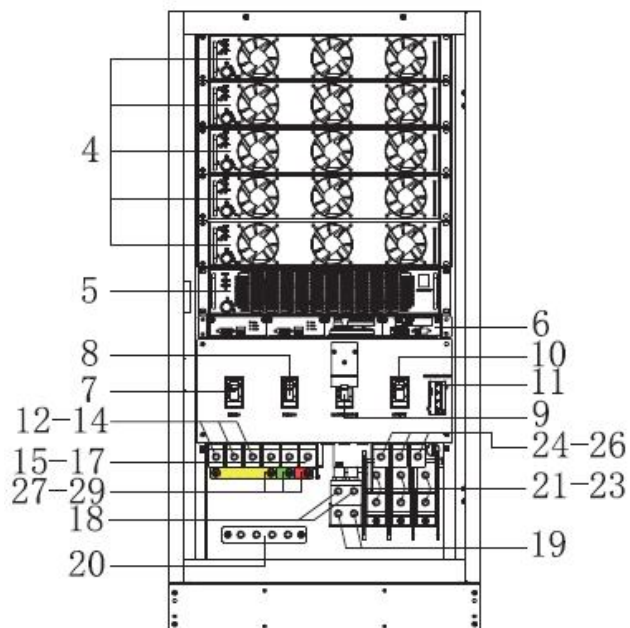
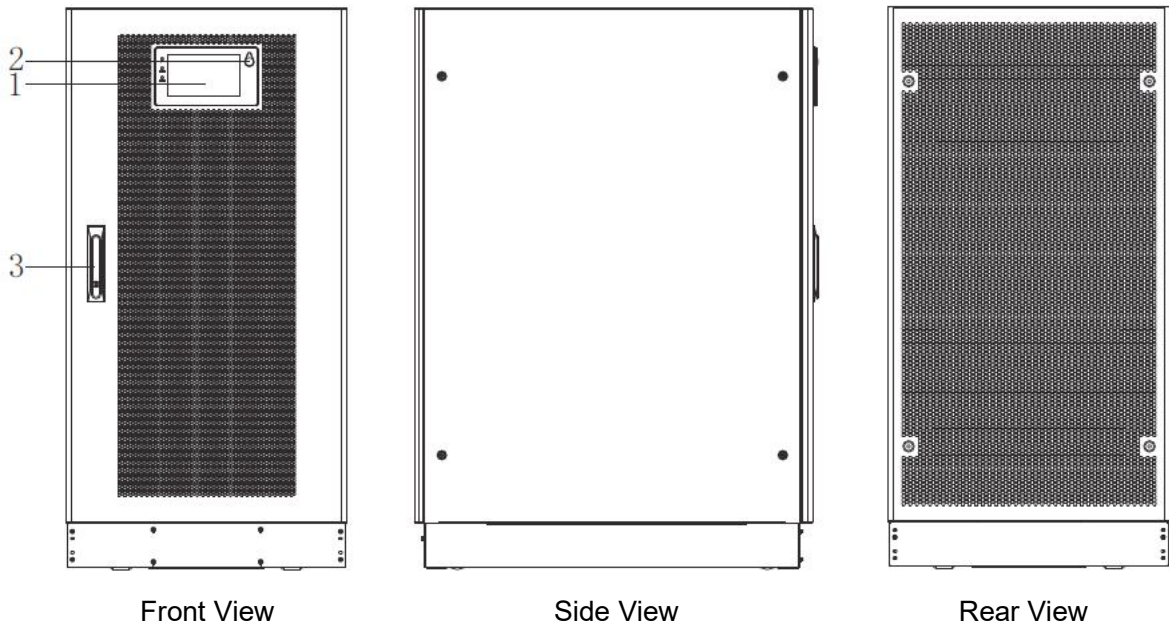

60-150kVA Inner Front View

200 - 300kVA cabinet

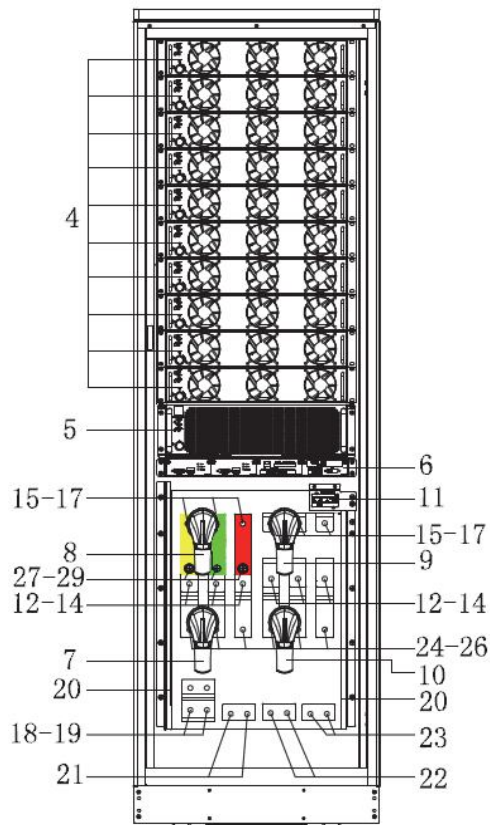
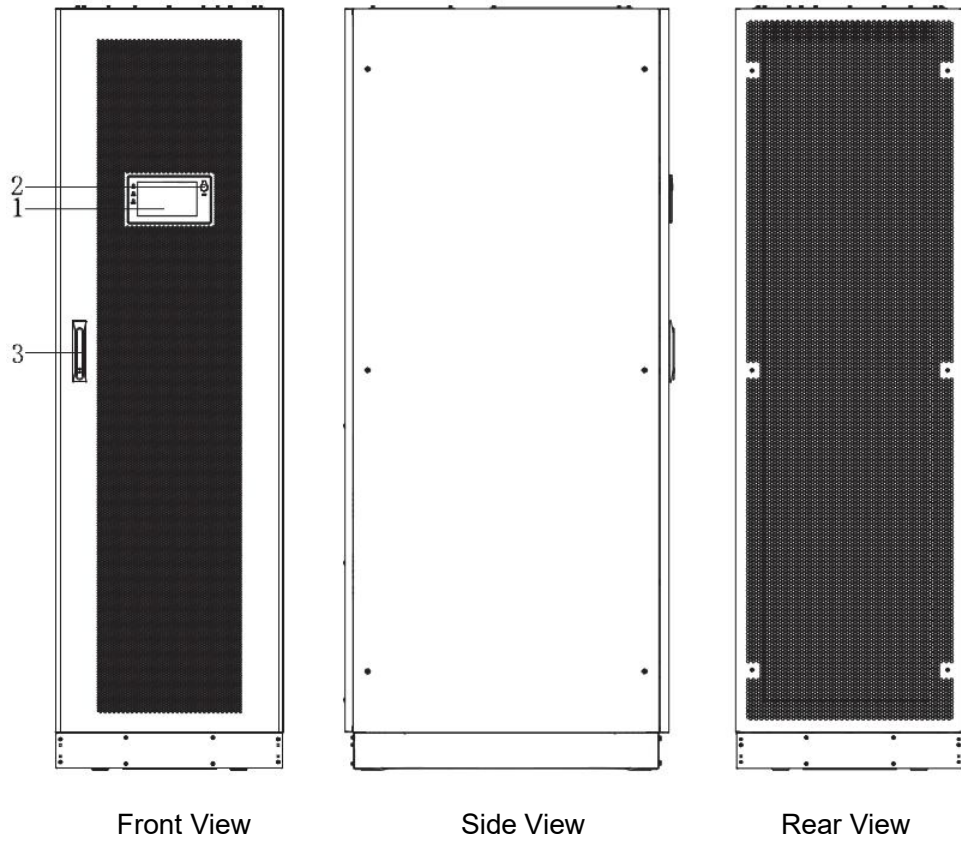

(1) LCD panel : Display UPS data and status
(2) EPO key : for location energy power stop
(3) Front door lock
(4) Power module
(5) Bypass module
(6) Control unit
(7) Mains switch
(8) Bypass switch
(9) Maintenance switch
(10) Output switch
(11) Intelligent Slot (SNMP card/ Relay card)
(12) Mains-A input copper bar
(13) Mains-B input copper bar
(14) Mains-C input copper bar
(15) Bypass-A input copper bar : Wiring must be used when mains-bypass separation
(16) Bypass-B input copper bar : Wiring must be used when mains-bypass separation
(17) Bypass-C input copper bar : Wiring must be used when mains-bypass separation
(18) Input neutral copper bar
(19) Output neutral copper bar
(20) Ground copper bar
(21) Battery positive copper bar
(22) Battery neutral copper bar
(23) Battery negative copper bar
(24) Output-A input copper bar
(25) Output-B input copper bar
(26) Output-C input copper bar
(27) Phase A mains-bypass common input connect copper bar
(28) Phase B mains-bypass common input connect copper bar
(29) Phase C mains-bypass common input connect copper bar

Control unit

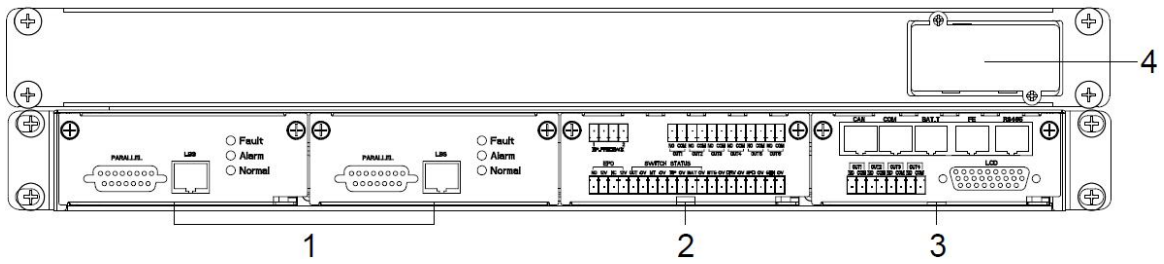

(1) ECU1/2 : Centralized control unit

(2) Dry-contact unit

(3) monitor unit

(4) Intelligent slot

ECU unit

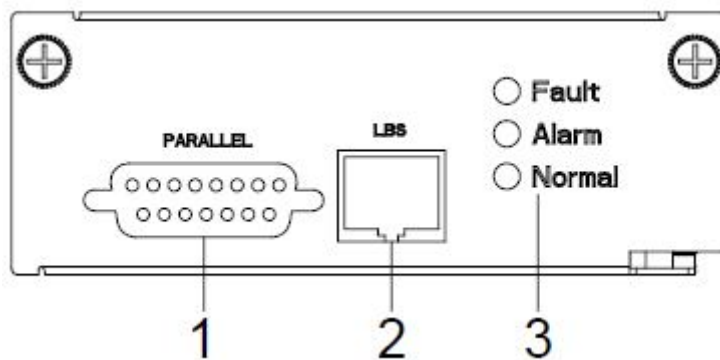

(1) PARALLEL port

(2) LBS port

(3) LED

Dry-contact unit

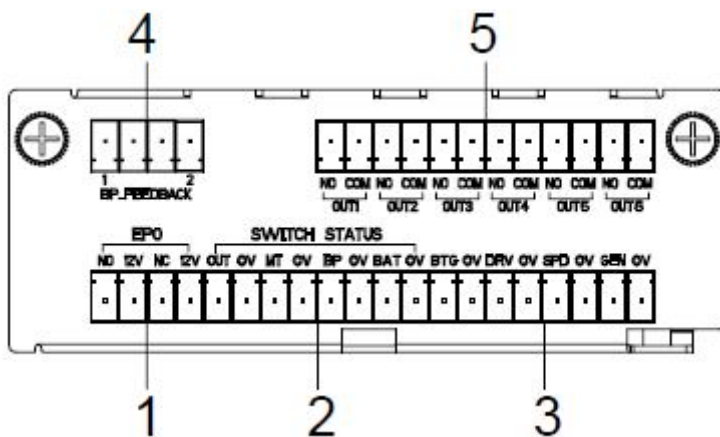

(1) EPO port

(2) SWITCH STATUS

(3) the other port

(4) BP_FEEDBACK : PIN1_NC, PIN2_NO, PIN4_common

(5) Optional dry contacts

Monitor unit

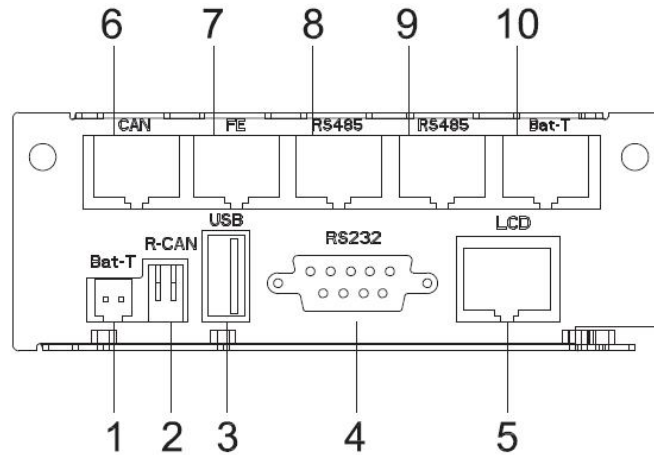

- (1) BAT_T : NTC temperature sensor port
- (2) R-CAN : CAN communication resistor adjust
- (3) USB port : for software update and history download
- (4) RS232 port : for communication
- (5) LCD port
- (6) CAN port : BMS port
- (7) FE : Net port (reserve)
- (8) RS485 port: for communication
- (9) RS485 port: for communication
- (10) BAT_T : battery temperature sensor port (RS485)

3.3 UPS module appearance

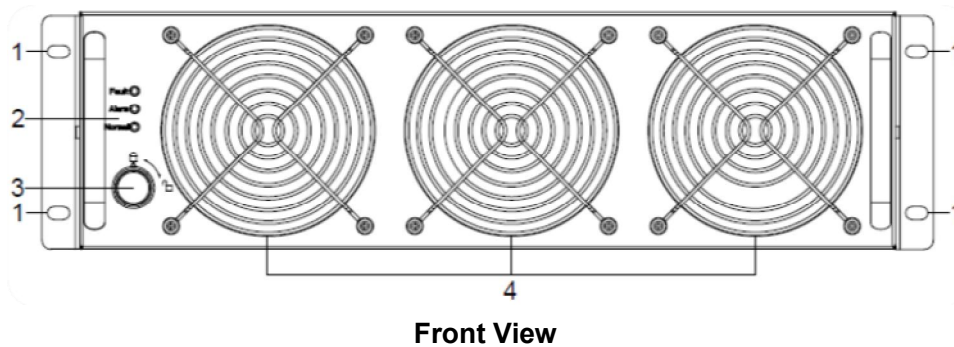

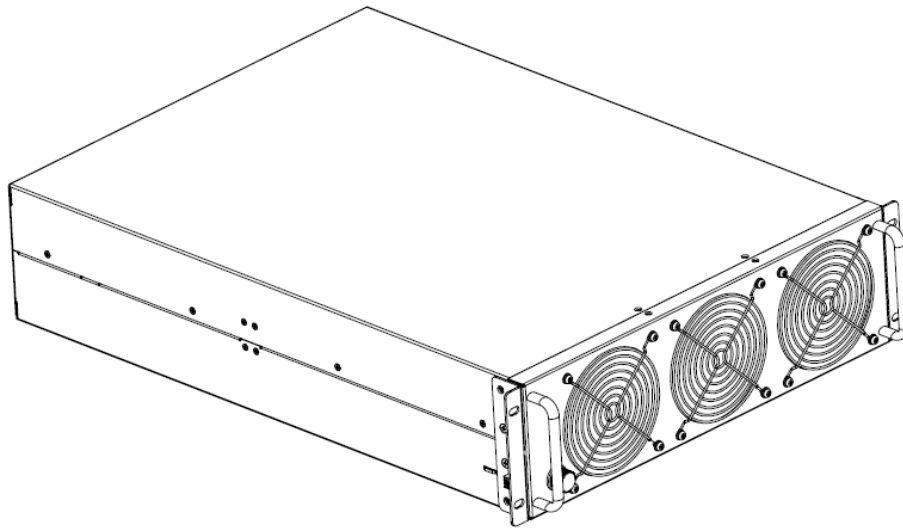

Side View

(1) Module fixed screw
(2) LED
(3) Module switch
(4) Fan

3.4 Installation notes

Note: Consider for the convenience of operation and maintenance, the space in front and back of the cabinet should be left at least 800mm and 800mm respectively when installing the cabinet.

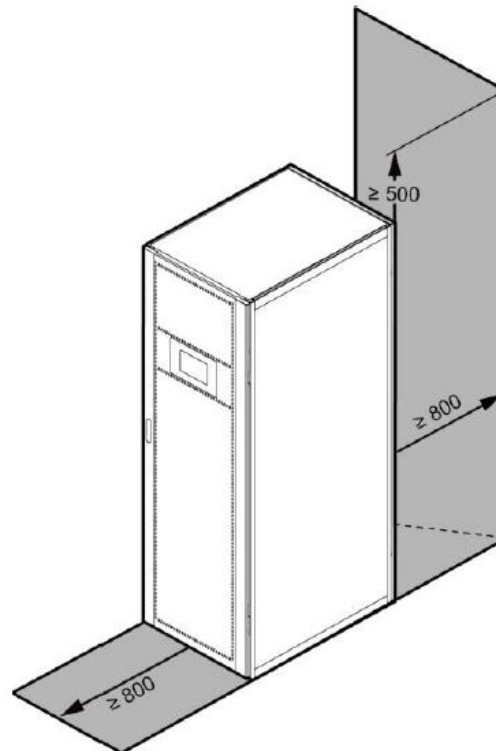

◆ Please place the UPS in a clean, stable environment, avoid the vibration, dust, humidity, flammable gas and liquid, corrosive. To avoid from high room temperature, a system of room extractor fans is recommended to be installed. Optional air filters are available if the UPS operates in a dusty environment.

◆ The environment temperature around UPS should keep in a range of 0°C ~ 40°C. If the environment temperature exceeds 40°C, the rated load capacity should be reduced by 12% per 5°C. The max temperature can't be higher than 50°C.

◆ If the UPS is dismantled under low temperature, it might be in a condensing condition. The UPS can't be installed unless the internal and external of the equipment is fully dry. Otherwise, there will be in danger of electric shock.

◆ Batteries should be mounted in an environment where the temperature is within the required specs. Temperature is a major factor in determining battery life and capacity. In a normal installation, the battery temperature is maintained between 15°C and 25°C. Keep batteries away from heat sources or main air ventilation area, etc.



WARNING!

Typical battery performance data are quoted for an operating temperature between 20°C and 25°C. Operating it above this range will reduce the battery life while operation below this range will reduce the battery capacity.

◆ Should the equipment not be installed immediately it must be stored in a room so as to protect it against excessive humidity and or heat sources.



CAUTION!

An unused battery must be recharged every 6months temporarily connecting the UPS to a suitable AC supply mains and activating it for the time required for recharging the batteries.

◆ The highest altitude that UPS may work normally with full load is 1500 meters. The load capacity should be reduced when this UPS is installed in place whose altitude is higher than 1500 meters, shown as the following table:

(Load coefficient equals max load in high altitude place divided by nominal power of the UPS)

Altitude(m)	1500	2000	2500	3000	3500	4000	4500	5000
Load coefficient	100%	95%	90%	85%	80%	75%	70%	65%

◆ The UPS cooling is depending on fan, so it should be kept in good air ventilation area. There are many ventilation holes on the front and rear, so they should not be blocked by any exotic obstacles.

3.5 External Protective Devices

For safety reasons, it is necessary to install, external circuit breaker at the input A.C. supply and the battery. This chapter provides guidelines for qualified installers that must have the knowledge of local wiring practices for the equipment to be installed.

◆ **External Battery**

The UPS and its associated batteries are protected against the effect of over-current through a DC compatible thermo-magnetic circuit-breaker (or a set of fuses) located close to the battery.

◆ **UPS Output**

Any external distribution board used for load distribution shall be fitted with protective devices that may avoid the risk of UPS overloaded.

◆ **Over-current**

Protection device shall be installed at the distribution panel of the incoming main supply. It may identify the power cables current capacity as well as the overload capacity

of the system.

3.6 Power Cables

- ◆ The cable design shall comply with the voltages and currents provided in this section, Kindly follow local wiring practices and take into consideration the environmental conditions (temperature and physical support media).

WARNING!



UPON STARTING, PLEASE ENSURE THAT YOU ARE AWARE OF THE LOCATION AND OPERATION OF THE EXTERNAL ISOLATORS WHICH ARE CONNECTED TO THE UPS INPUT/BYPASS SUPPLY OF THE MAINS DISTRIBUTION PANEL. CHECK TO SEE IF THESE SUPPLIES ARE ELECTRICALLY ISOLATED, AND POST ANY NECESSARY WARNING SIGNS TO PREVENT ANY INADVERTENT OPERATION

3.6.1 Recommended cross-sectional areas for power cables

- ◆ For future expansion purpose, it is economical to install power cable according to the full rating capacity initially. The diameter of cable is shown below:

UPS Cabinet (kVA)	Cable Dimension				
	AC Input (mm ²)	BPS Input (mm ²)	AC Output (mm ²)	DC Input (mm ²)	Grounding (mm ²)
30	10	10	10	25	10
45	16	16	16	35	16
50	16	16	16	50	16
60	35	35	35	70	35
75	35	35	35	95	35
90	70	70	70	120	70
100	95	95	95	120	95
120	95	95	95	150	95
125	95	95	95	185	95
135	95	95	95	185	95
150	120	120	120	185	120
180	150	150	150	120*2	150
200	185	185	185	120*2	185
225	185	185	185	150*2	185
250	120*2	120*2	120*2	185*2	120*2
270	120*2	120*2	120*2	185*2	120*2
300	150*2	150*2	150*2	240*2	150*2

- ◆ When selecting, connecting, and routing power cables, follow local safety regulations and rules.
- ◆ If external conditions such as cable layout or ambient temperatures change, perform verification in accordance with the IEC-60364-5-52 or local regulations.
- ◆ If the rated voltage is 400 V, multiply the currents by 0.95. If the rated voltage is 415 V, multiply the currents by 0.92.
- ◆ If primary loads are non-linear loads, increase the cross-sectional areas of neutral wires 1.5–1.7 times.
- ◆ The nominal battery discharge current refers to the current of forty 12 V batteries at 480V in standard configuration.
- ◆ The maximum battery discharge current refers to the current when forty 12 V batteries in standard configuration, that is, two hundred and forty 2 V battery cells (1.67 V/cell), stop discharging.

- ◆ The battery cable specifications are selected based on 40 batteries by default and compatible with application scenarios with 30–40 batteries.
- ◆ When the mains input and bypass input share a power source, configure both types of input power cables as mains input power cables. The cables listed in Table are used only when the following requirements are met:
 - Routing mode: Routing the cables over the cable ladder or bracket in a single layer (IEC60364-5-52 middle E).
 - The ambient temperature is 30°C.
 - The AC voltage loss is less than 3%, and the DC voltage loss is less than 1%.
 - 90°C copper flexible cable.
 - The length of the AC power cables of a UPS is no longer than 30 m and DC power cables no longer than 50 m.

3.6.2 Power cable connector requirements

UPS Cabinet (kVA)	Connector	Connection Mode	Bolt Type	Bolt Hole Diameter	Torque
30/50 45/60 50/100 75/125 120/150 1.2 m	Mains input connector	Crimped OT terminals	M10	10.5mm	26N•m
	Bypass input connector	Crimped OT terminals	M10	10.5mm	26N•m
	Battery input connector	Crimped OT terminals	M10	10.5mm	26N•m
	Output connector	Crimped OT terminals	M10	10.5mm	26N•m
	Grounding connector	Crimped OT terminals	M10	10.5mm	26N•m
90/100 135/150 180/200 225/250 270/300 2 m	Mains input connector	Crimped OT terminals	M12	12.5mm	26N•m
	Bypass input connector	Crimped OT terminals	M12	12.5mm	26N•m
	Battery input connector	Crimped OT terminals	M12	12.5mm	26N•m
	Output connector	Crimped OT terminals	M12	12.5mm	26N•m
	Grounding connector	Crimped OT terminals	M12	12.5mm	26N•m

3.6.3 Recommended input front-end and output back-end circuit breakers

UPS Cabinet (kVA)	Mains input circuit breaker	Bypass input circuit breaker	Maintenance circuit breaker	Output circuit breaker	Battery circuit breaker
30k	63A 3P	63A 3P	63A 4P	63A 3P	100A 3P
45k	80A 3P	80A 3P	80A 4P	80A 3P	160A 3P
50k	100A 3P	100A 3P	100A 4P	100A 3P	160A 3P
60k	125A 3P	125A 3P	125A 4P	125A 3P	175A 3P
75k	160A 3P	160A 3P	160A 4P	160A 3P	250A 3P
90/100k	200A 3P	200A 3P	200A 4P	200A 3P	315A 3P
120/125k	250A 3P	250A 3P	250A 4P	250A 3P	400A 3P
135/150k	250A 3P	250A 3P	250A 4P	250A 3P	500A 3P
180/200k 225k	400A 3P	400A 3P	400A 4P	400A 3P	630A 3P
250/270K	500A 3P	500A 3P	500A 4P	500A 3P	800A 3P
300K	600A 3P	600A 3P	600A 4P	600A 3P	1000A 3P



CAUTION!

Protective earth cable: Connect each cabinet to the main ground system. For Grounding connection, follow the shortest route possible.



WARNING!

FAILURE TO FOLLOW ADEQUATE EARTHING PROCEDURES MAY RESULT IN ELECTROMAGNETIC INTERFERENCE OR IN HAZARDS INVOLVING ELECTRIC SHOCK AND FIRE

3.7 Power cable connect

Before equipment has been installed, must confirm the input source type, common input or Split input, if the input source is dual input, must remove the copper bar that connected bypass and mains.

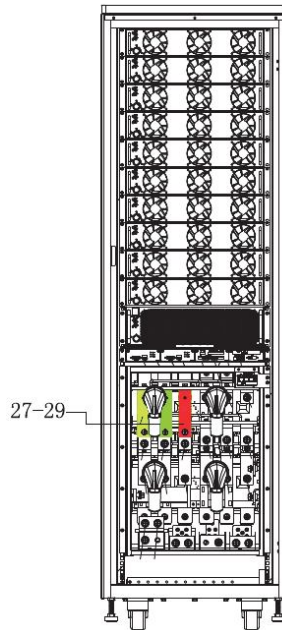

Choose appropriate power cable. (Refer to the table above) and pay attention to the diameter of the connection terminal of the cable that should be greater than or equal to that of the connection poles;

Wiring

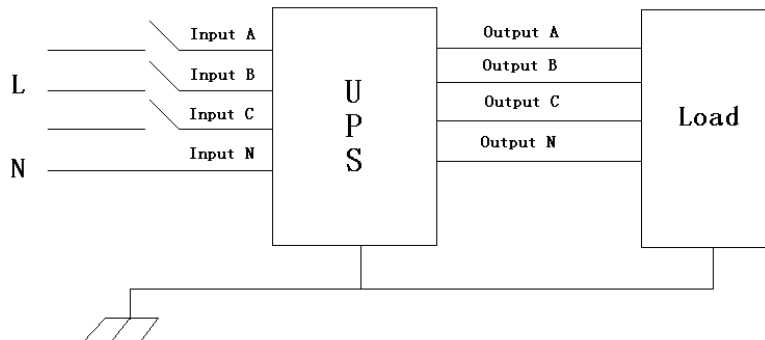

WARNING!



If the load equipment is not ready to accept power on the arrival of the commissioning engineer then ensure that the system output cables are safely isolated at their ends

Connect the safety earth and any necessary bonding earth cables to

the copper earth screw located on the floor of the equipment below the power connections. All cabinets in the UPS must be grounded properly.



CAUTION!

The earthing and neutral bonding arrangement must be in accordance with local and national codes of practice.

3.9 Battery connection

The UPS adopts positive and negative double battery framework, total 30(optional 32/34/36/38/40/42/44/46/48/50) in series. A neutral cable is retrieved from the joint between the cathode of the 15th (16th/17th/18th/19th/20th/21th/22th/23th/24th/25th) and the anode of the 16th (17th/18th/19th/20th/21th/22th/23th/24th/25th/26th) of the batteries. Then the neutral cable, the battery Positive and the battery negative are connected with the UPS respectively. The battery sets between the Battery anode and the neutral are called positive batteries and that between neutral and cathode are called negative ones. The user can choose the capacity and the numbers of the batteries according to their desire.

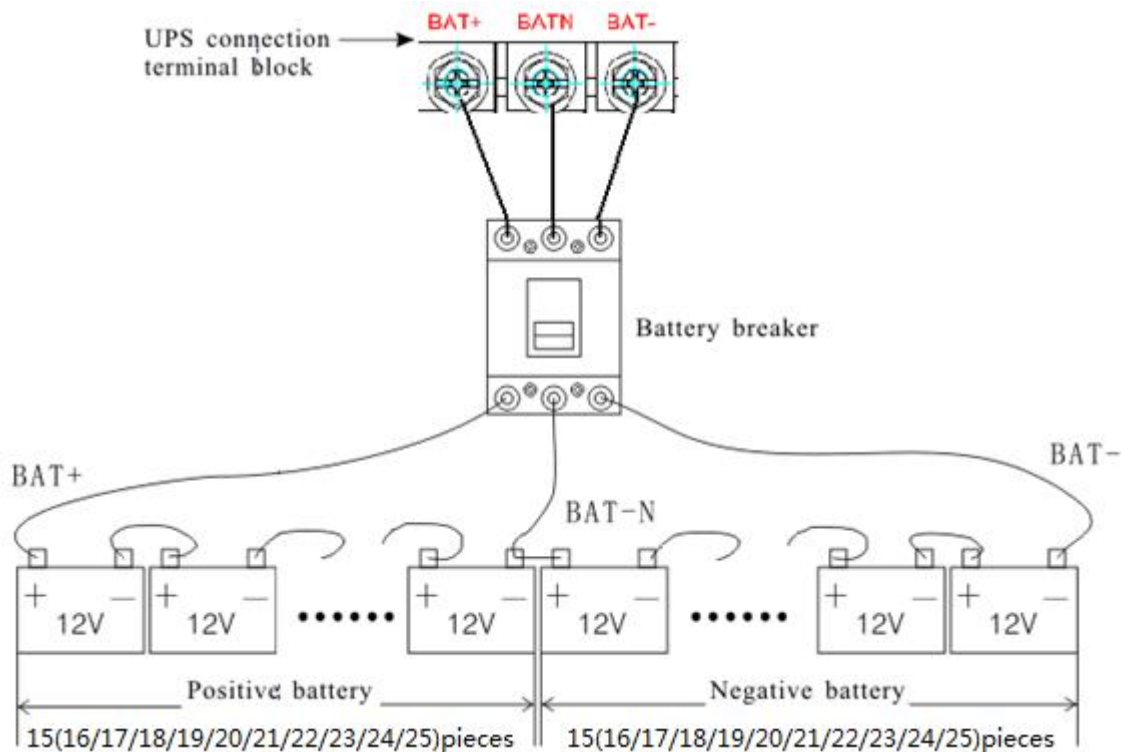

Note:

The BAT+ of the UPS connect poles is connected to the anode of the positive battery, the BAT-N is connected to the cathode of the positive battery and the anode of the negative battery, the BAT- is connected to the cathode of the negative battery.

Factory setting of the long-run unit is battery quantity---40pcs, battery capacity---12V 100AH. When connecting 30/32/34/36/38/42/44/46/48/50 batteries, please re-set desired battery quantity and its capacity after UPS starts at AC mode. Charger current could be adjusted automatically according to battery capacity selected. All related settings can be done through LCD panel or monitoring software.

CAUTION!



Ensure correct polarity battery string series connection. i.e. inter-tier and inter block connections are from (+) to (-) terminals.

Don't mix batteries with different capacity or different brands, or even mix up new and old batteries, either.

WARNING!



Ensure correct polarity of string end connections to the Battery Circuit Breaker and from the Battery Circuit Breaker to the UPS terminals i.e. (+) to (+) / (-) to (-) but disconnect one or more battery cell links in each tier. Do not reconnect these links and do not close the battery circuit breaker unless authorized by the commissioning engineer.

3.10 Online UPS Modules Replacement

For the UPS, modules must be inserted to make a complete UPS system.

The replacement of UPS module is very simple and can be operated online. The control system of the UPS can detect the inserted or removed module(s) automatically. The user may operate easily by following the steps mentioned below.

◆ **NOTE: The UPS module is rather heavy, please move it by two people!**

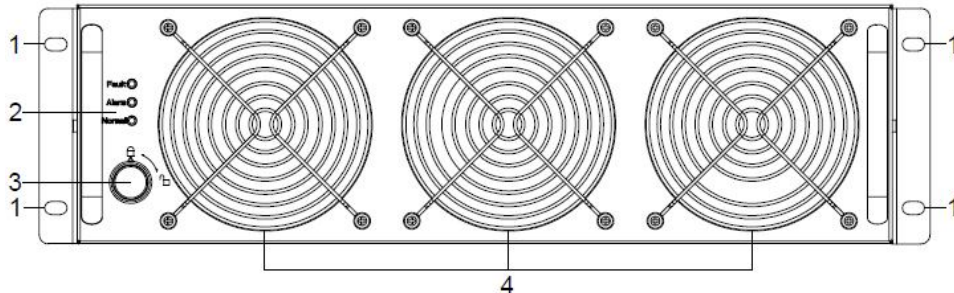

◆ Insert module

- (1) Remove decorated panel;
- (2) Put the UPS module in the cabinet module slot. Push the module along the slot into the cabinet until the module is inserted properly, then the indicator will flash.
- (3) Fix the module with screws (1) at the positioning screw holes;
- (4) Switch on the module_ON switch (3) at the left of the module panel, then the red indicator (2) will off.
- (5) After the modules start up, the system will detect the modules inserted automatically and parallel up the modules into whole system.

◆ Remove UPS module

Switch off the module_ON switch (3) at the left of the module panel, then the red indicator (2) will light and green indicator flash. Remove the screws (1) of the module and remove the module from the cabinet.

WARNING!



- (1) Before start the module, the module_ON switch must on the "ON" status and the red indicator must flash or off.
- (2) Before remove the module, the module_ON switch must on the "OFF" status and the red indicator must light.
- (3) When insert the module under battery mode, please press "ON" button at module's LCD panel until the module starts.

3.11 UPS Multi—Module Installation

The basic installation procedure of a parallel system comprising of two or more UPS modules is the same as that of single module system. The following sections introduce the installation procedures specified to the parallel system.

3.11.1 Cabinet installation

Connect all the UPS needed to be put into parallel system as below picture.

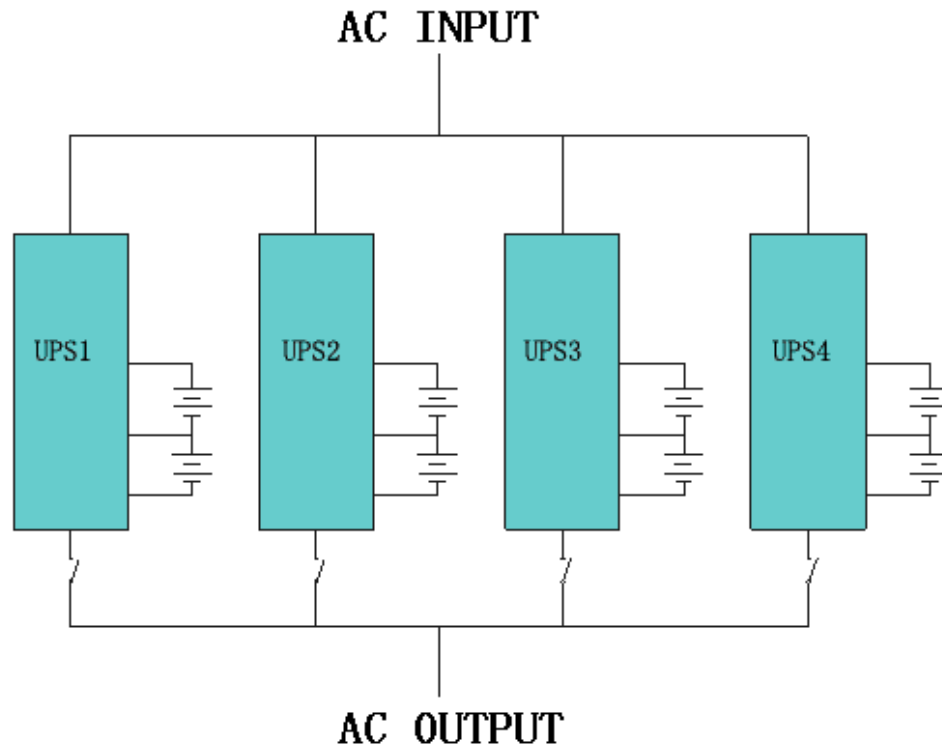

Make sure each UPS input switch is in “off” position and there is no any output from each UPS connected. Battery groups can be connected separately or in parallel, which means the system itself provides both separate battery and common battery.



CAUTION!

A group of parallel systems is equivalent to a large capacity UPS, but it has higher reliability. In order to ensure that all UPS machines are current sharing, and comply with the relevant wiring rules, the following requirements should be met:

- ◆ All UPS must be the same rated and connected to the same way bypass power supply.
- ◆ Bypass and the mains input power must be received with the same neutral.
- ◆ The output of all UPS machines must be connected to a common output bus.
- ◆ All bypass input cables and UPS output cables should be of the same length and specification, which is to make the machine operate in the bypass mode and compare the current sharing.

3.11.2 Parallel cable installation

Shielded and double insulated control cables available must be interconnected in a ring configuration between UPS modules as shown below. The parallel control board is mounted on each UPS module. The ring configuration ensures high reliability of the control.

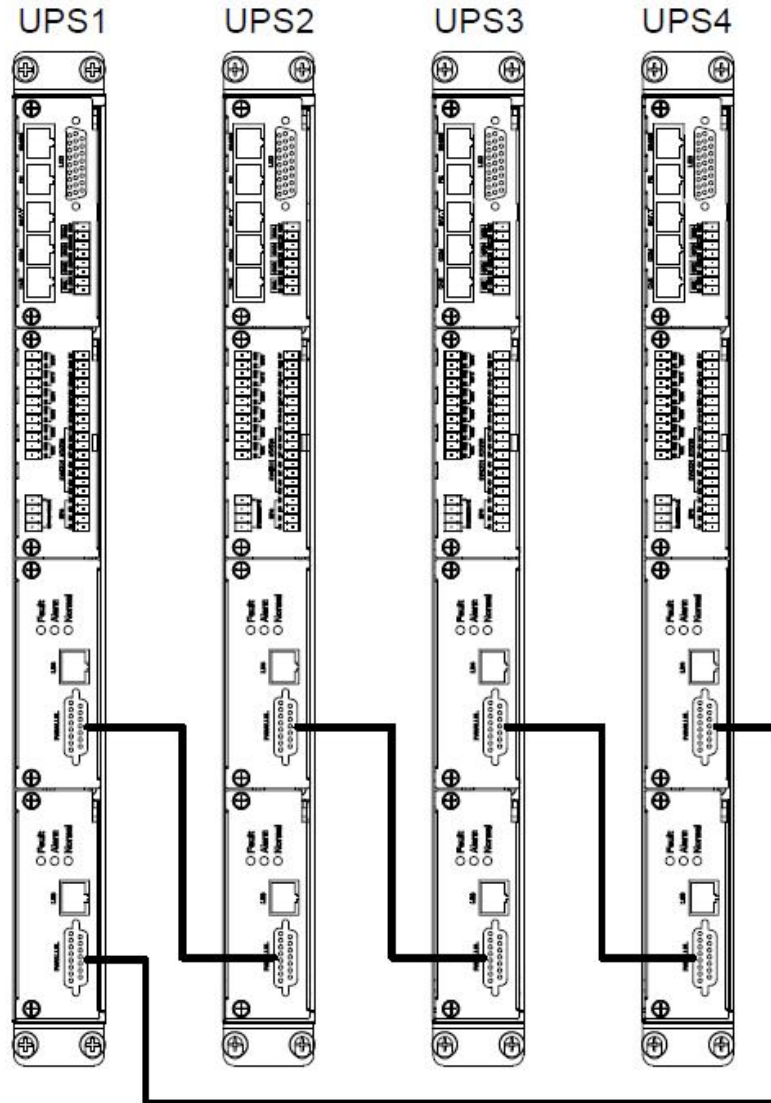

3.12 LBS installation (optional)

LBS system contains LCD set, cable connect and STS device.

3.12.1 LCD setting

Set every UPS of the systems to be LBS Master or LBS Slave. For instance if the UPS belongs to LBS master system, its LBS setting must be set to Master.

3.12.2 LBS cable installation

The two ports of one mesh wire should be plug into RJ45 interface of any one UPS of both master and slave system.

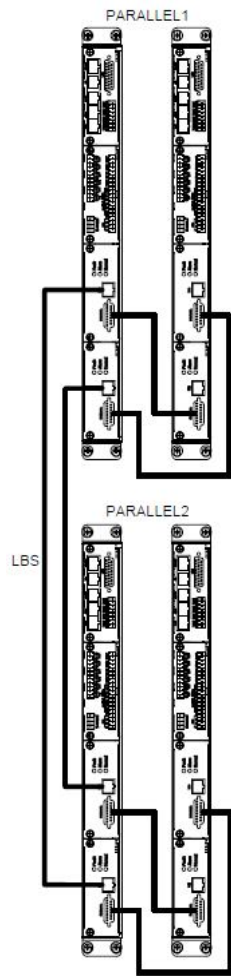

3.12.3 UPS installation

The whole systems are showed below.

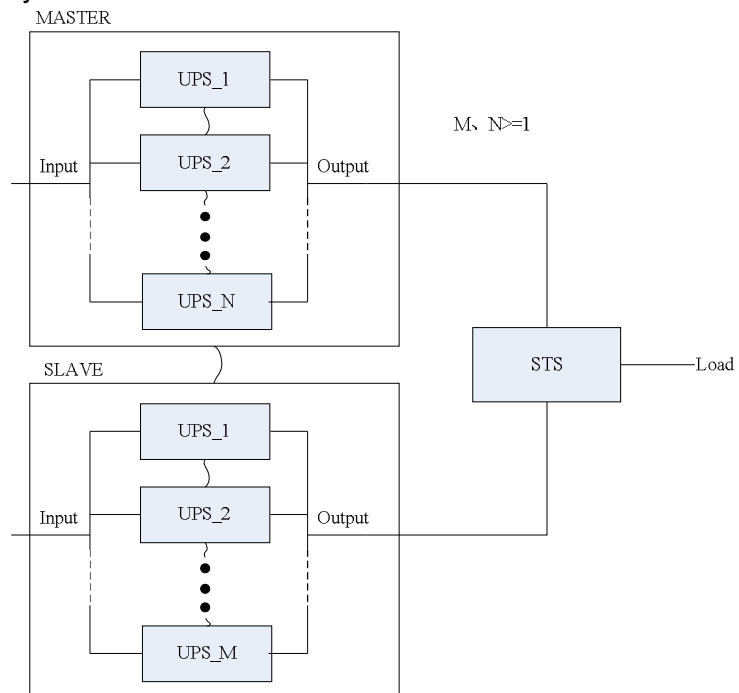

4. Operation

4.1 Operation Modes

The UPS is a double-conversion on-line UPS that may operate in the following alternative modes:

◆ Normal mode

The rectifier/charger derives power from the AC Mains and supplies DC power to the inverter while floating and boosting charge the battery simultaneously. Then, the inverter converts the DC power to AC and supplies to the load.

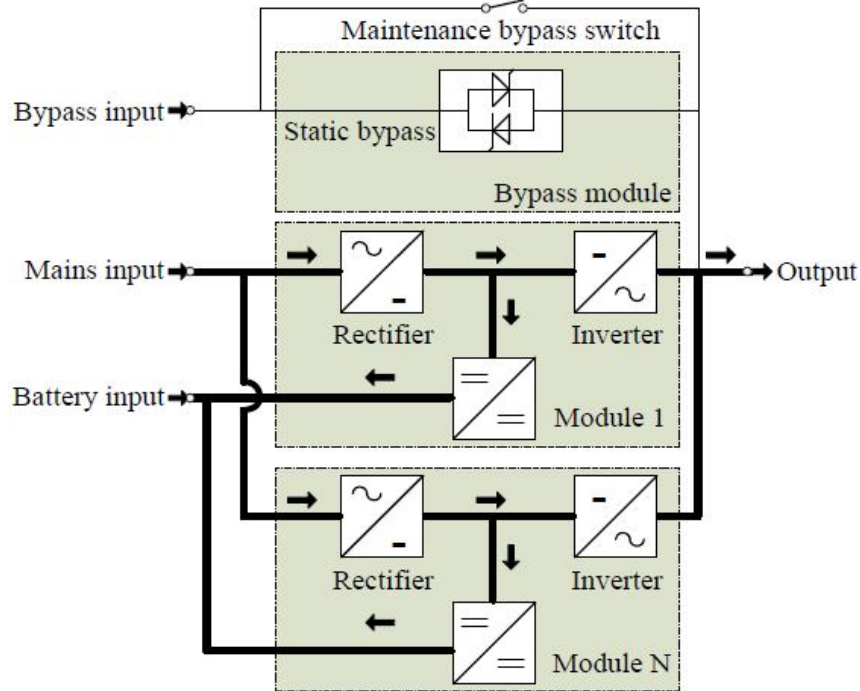

◆ Battery mode (Stored Energy Mode)

If the AC mains input power fails, the inverter, which obtains power from the battery, supplies the critical AC load. There is no power interruption to the critical load. The UPS will automatically return to Normal Mode when AC recovers.

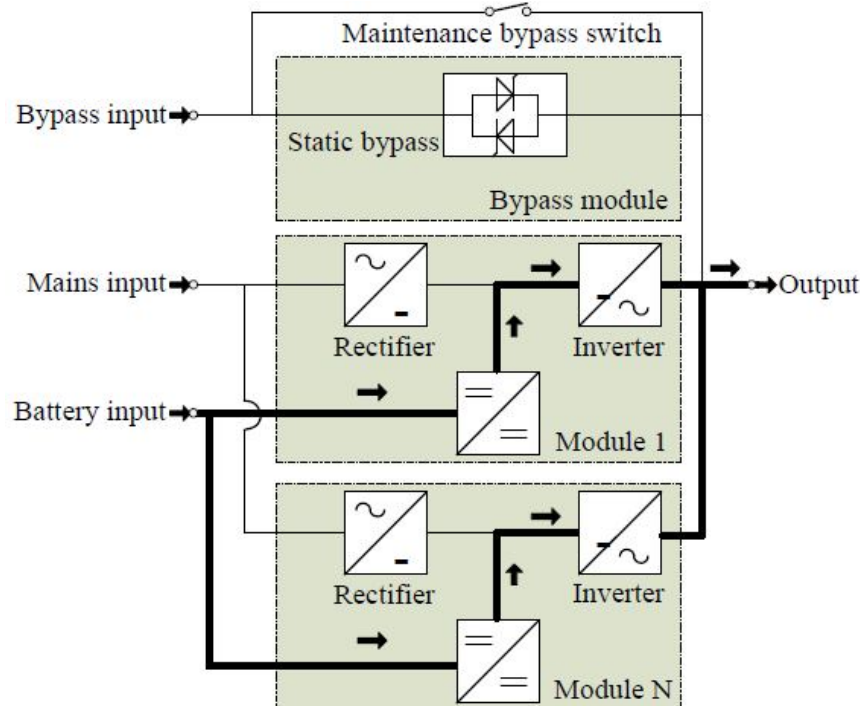

◆Bypass mode

If the inverter is out of order, or if overload occurs, the static transfer switch will be activated to transfer the load from the inverter supply to bypass supply without interruption to the critical load. In the event that the inverter output is not synchronized with the bypass AC source, the static switch will perform a transfer of the load from the inverter to the bypass with power interruption to the critical AC load. This is to avoid paralleling of unsynchronized AC sources. This interruption is programmable but typically set to be less than an electrical cycle e.g. less than 15ms (50Hz) or less than 13.33ms (60Hz).

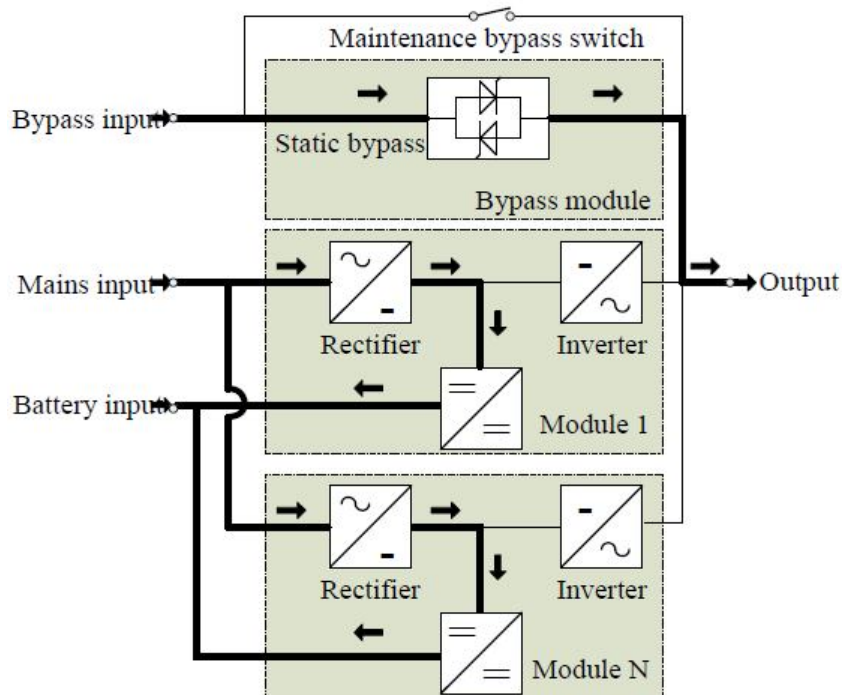

◆ECO Mode

When the UPS is at AC Mode and the requirement to the load is not critical, the UPS can be set at ECO mode in order to increase the efficiency of the power supplied. At ECO mode, the UPS works at Line-interactive mode, so the UPS will transfer to bypass supply. When the AC is out of set window, the UPS will transfer from bypass to Inverter and supplies power from the battery, and then the LCD shows all related information on the screen.

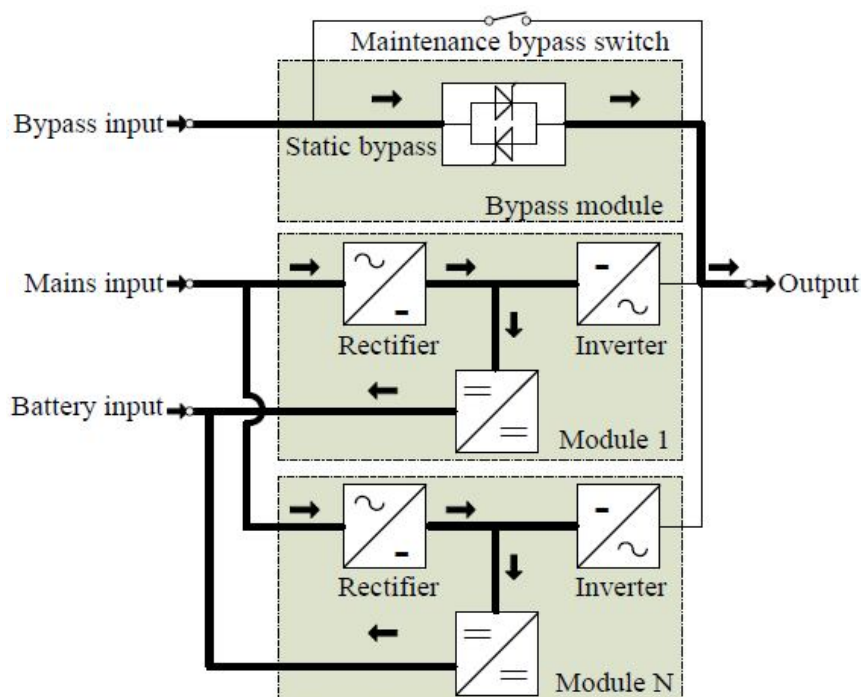

◆ Maintenance mode (Manual Bypass)

A manual bypass switch is available to ensure continuity of supply to the critical load when the UPS is out of order or in repair. This manual bypass switch is fitted for all UPS modules and bears for equivalent rated load.

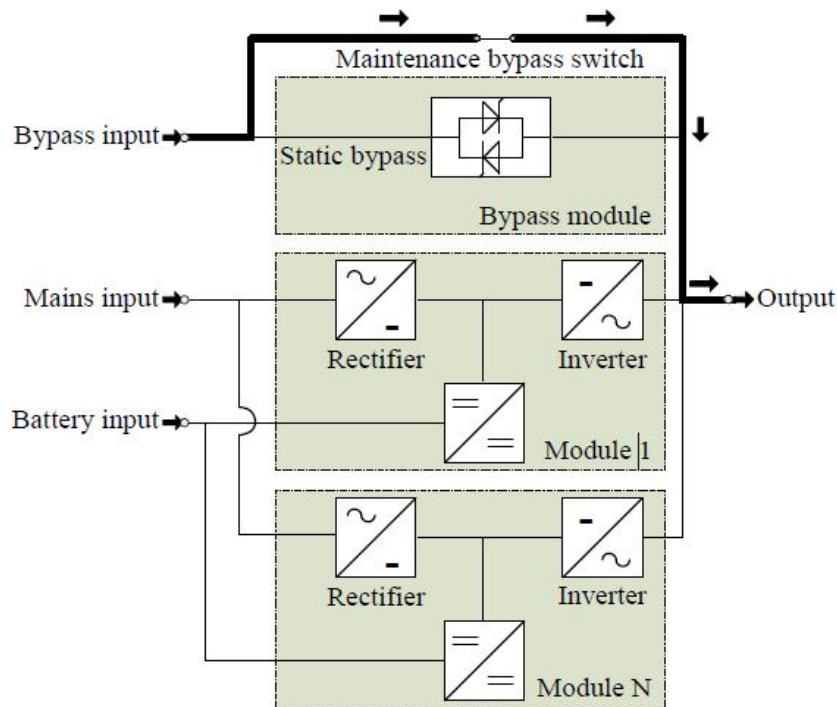

4.2 Turn on/off UPS

4.2.1 Restart procedure



CAUTION!

MAKE SURE GROUNDING IS PROPERLY DONE!

- ◆ Set the Battery Switch to the "ON" position according to the user's manual.
- ◆ Open the front and rear doors of the UPS to access to the main power switches. During this procedure the output terminals will become alive.



CAUTION!

Check to see if the load is safely connected with the output of the UPS. If the load is not ready to receive power from the UPS, make sure that it is safely isolated from the UPS output terminals

- ◆ Turn ON the bypass and input switches of the UPS, make sure that "Bypass module" insert the cabinet and fix with screws and the module_in switch at the on status

When AC MAINS input voltage within the range, and the rectifiers of the UPS will be started up in 30 seconds, then the inverter is started completely. When the output switch is "ON", the inverter LED lights up.

- ◆ Switch ON output switch

If the rectifier of the module does not start-up, the green LED will flash, bypass module green LED will light on, the power module green LED will flash. when UPS turn to inverter mode power module and display panel green LED will light on.

No matter the UPS is operated normally or not, the LCD display will indicate current status.

4.2.2 Test procedure



CAUTION!

The UPS is operating normally.
It may take 60 seconds to boost up the system and perform self-test completely.

- ◆ Switch off the MAINS to simulate utility failure, the rectifier will turn off and the battery should feed the inverter without interruption.
- ◆ Switch on the MAINS to simulate utility recovery, the rectifier will restart automatically after 20 seconds and the inverter will supply to the load. It is suggested to use Dummy loads for testing. The UPS can be loaded up to its maximum capacity during load test.

4.2.3 Cold start procedure

CAUTION!



Follow these procedures when the input AC Utility Failure, but battery is normal

- ◆ Switch on the battery switch.
The battery will feed the Auxiliary power board.
- ◆ Switch on the Output switch
- ◆ Trigger the cold start button of the bypass module.

When battery normal, rectifier starts operation, 30s later, inverter starts and operates and the green LED will light on.

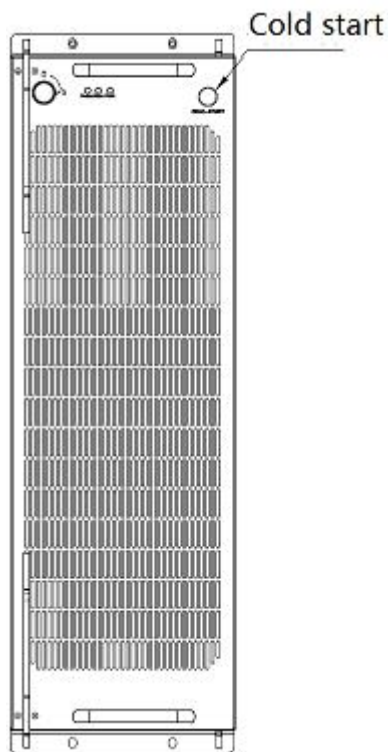

CAUTION!

Wait for approximately 30 seconds before you press the black start key

4.2.4 MAINTENANCE BYPASS

To supply the load via Mains, you may simply active the internal mechanical bypass switch.



CAUTION!

The load is not protected by the UPS when the internal mechanical bypass system is active and the power is not conditioned.

Switch to mechanical bypass



CAUTION!

If the UPS is running normally and can be controlled through the display, carry out steps 1 to 5; otherwise, jump to Step 4.

- ◆ Open the cover of maintenance switch, the UPS turns to bypass mode automatically.
- ◆ Switch on MAINTANCE switch;
- ◆ Switch OFF BATTERY switch;
- ◆ Switch OFF the MAINS switch;
- ◆ Switch OFF OUTPUT switch;

At this time the bypass source will supply to the load through the MAINTENANCE switch.

Switch to normal operation (from mechanical bypass)



CAUTION!

Never attempt to switch the UPS back to normal operation until you have verified that there are no internal UPS faults

- ◆ Open the front and rear doors of the UPS to be easily access to the main power switches
- ◆ Switch ON the output switch;
- ◆ Switch ON the input switch;
- ◆ Switch ON the battery switch;

The UPS powers from the static bypass instead of the maintenance bypass.

- ◆ Switch OFF the maintenance bypass switch, then the output is supplied by the bypass of the modules.
- ◆ Put on the maintenance switch cover.

The rectifier will operate normally after 30 seconds. If the inverter works normally, the system will be transferred from bypass mode to normal mode.

4.2.5 Shut down procedure



CAUTION!

This procedure should be followed to completely shut down the UPS and the LOAD. After all power switches, isolators and circuit breakers are opened, there will be no output.

- ◆ Press the INVERTER OFF key on the LCD display;

- ◆ Switch OFF the BATTERY switch;
- ◆ Open the UPS door to easily access to the main power switch;
- ◆ Switch OFF the input switch.
- ◆ Switch OFF the OUTPUT switch. The UPS shuts down;



WARNING!

Wait for about 5 minutes for the internal D.C. bus bar capacitors to be completely discharged.

4.2.6 Startup procedure for parallel system

- ◆ Connect parallel cable, input/output cable, and battery cable well; modify the parallel board jumpers correctly.
- ◆ Measure the positive and negative battery pack voltage. Battery switch is opened temporarily.
- ◆ Switch ON the output switch at the front door.
- ◆ According to the startup procedure for single unit, set the operation mode of each UPS: single mode is changed to parallel mode; set the parallel number for each UPS; up to 4 units can be parallel; set the ID of each cabinet, the ID of each unit must be different.
- ◆ Switch ON the input switch. Close the external input switch and start from mains.
- ◆ After start from mains, check the LCD interface of each UPS to see if the ID, VA is the same with the actual values.
- ◆ Switch ON the external battery switch of each UPS. Check if the charging current displayed in LCD is normal.



Note!

The UPS cannot be parallel until each single unit is normal.

4.3 The Display

The LCD shows the UPS operating flow chart, and there are the data entrance of input, output, battery, as well as the setting information.



4.4 Display Messages/Troubleshooting

This section lists the event and alarm messages that the UPS might display. The messages are listed in alphabetical order. This section is listed with each alarm message to help you troubleshoot problems.

Fault Information

No	Fault Cord	UPS Alarm Warning	Buzzer	LED
1	2	REC Over Temperature	Twice per second	Fault LED lit
2	3	REC par. cable Fault	Twice per second	Fault LED lit
3	4	REC Over Current	Beep continuously	Fault LED lit
4	5	REC Power Fault	Beep continuously	Fault LED lit
5	7	Input SCR Fault	Beep continuously	Fault LED lit
6	10	Battery SCR Fault	Beep continuously	Fault LED lit
7	12	Charge SCR Fault	Beep continuously	Fault LED lit
8	14	Fan Fault	Beep continuously	Fault LED lit
9	17	Fan Power fault	Beep continuously	Fault LED lit
10	18	Charger Over Temp.	Beep continuously	Fault LED lit
11	19	Soft Start Failed	Beep continuously	Fault LED lit
12	20	BAT Charger Fault	Beep continuously	Fault LED lit
13	22	REC Comm. Fault	Once per 2 seconds	Fault LED blinking
14	25	REC Initializes Fault	Beep continuously	Fault LED lit
15	29	Unit insert fault	Once per 2 seconds	Fault LED lit
16	99		Once per 2 seconds	Fault LED lit
17	30	Rectifier Fault	Beep continuously	Fault LED lit
18	65	Inverter Fault	Beep continuously	Fault LED lit
19	68	INV IGBT SHORT	Beep continuously	Fault LED lit
20	71	Inverter relay Short	Beep continuously	Fault LED lit
21	74	Inverter relay Broken	Beep continuously	Fault LED lit
22	77	INV par. cable Fault	Twice per second	Fault LED lit
23	81	Output Short Circuit	Once per second	Fault LED blinking
24	84	INV Comm. Fault	Once per 2 seconds	Fault LED blinking
25	87	INV Initializes Fault	Beep continuously	Fault LED lit
26	90	INV self-test Fault	Beep continuously	Fault LED lit
27	94	DC Component Fault	Once per 2 seconds	Fault LED lit
28	97	DC bus abnormal	Beep continuously	Fault LED lit
29	100	INV DSP Power Fault	Beep continuously	Fault LED lit
30	102	INV Over Temperature	Twice per second	Fault LED lit
31	104	Load Sharing Fault	Twice per second	Fault LED lit
32	106	Cabinet mode Fault	Beep continuously	Fault LED lit
33	107	Fuse Broken	Beep continuously	Fault LED lit
34	129	Par. cable Fault	Twice per second	Fault LED lit
35	134	ECU Insert Fault	Once per 2 seconds	Fault LED lit
36	136	ECU Power Fault	Beep continuously	Fault LED lit
37	139	ECU Comm. Fault	Beep continuously	Fault LED lit
38	141	ECU Initializes Fault	Once per 2 seconds	Fault LED blinking
39	145	Bypass SCR Broken	Beep continuously	Fault LED lit
40	194		Beep continuously	Fault LED lit
41	148	Bypass SCR short	Beep continuously	Fault LED lit
42	197		Beep continuously	Fault LED lit
43	151	BPS Over Temperature	Beep continuously	Fault LED lit
44	207		Beep continuously	Fault LED lit
45	154	Output CT Reverse	Beep continuously	Fault LED lit
46	155	Dry-contact Power Fault	Beep continuously	Fault LED lit
47	156	Dry-contact Comm. Fault	Beep continuously	Fault LED lit
48	157	Bypass Feedback Fault	Beep continuously	Fault LED lit

49	193	BYS Par.cable Fault	Beep continuously	Fault LED lit
50	200	BPS Comm. Fault	Beep continuously	Fault LED lit
51	202	Bypass Initializes Fault	Beep continuously	Fault LED lit
52	205	Bypass connected fault	Beep continuously	Fault LED lit
53	210	Bypass Fan Fault	Beep continuously	Fault LED lit

Alarm Information

No	Alarm Cord	UPS Alarm Warning	Buzzer	LED
1	259	Battery Over Voltage	Once per second	Alarm LED lit
2	260	BAT Low Pre-warning	Once per second	Alarm LED lit
3	261	Battery Reverse	Twice per second	Alarm LED lit
4	262	Battery EOD	Once per second	Alarm LED lit
5	263	Battery Voltage low	Once per second	Alarm LED lit
6	264	No Battery	Once per second	Alarm LED lit
7	265	Input Phase Reverse	Once per second	Alarm LED lit
8	266	Input N-Line lost	Twice per second	Alarm LED lit
9	267	Mains Freq. Abnormal	Once per 2 seconds	Alarm LED lit
10	268	Mains Volt. Abnormal	Once per 2 seconds	Alarm LED lit
11	269	REC Comm. Error	Once per 2 seconds	Alarm LED lit
12	270	Mains input lost	Once per 2 seconds	Alarm LED lit
13	271	Set Data Err.	Once per 2 seconds	Alarm LED lit
14	289	INV Par. cable abnormal	Once per 2 seconds	Alarm LED lit
15	293	INV Overload	Once per 2 seconds	Alarm LED lit
16	294	INV not synchronized	Beep continuously	Alarm LED lit
17	298	INV Set Data Err	Once per 2 seconds	Alarm LED lit
18	297	INV Comm. Error	Once per 2 seconds	Alarm LED lit
19	321	Bypass Switch to Num	Once per 2 seconds	Alarm LED lit
20	322	Unit quantity mismatch	Once per 2 seconds	Alarm LED lit
21	323	Parallel Overload	Once per 2 seconds	Alarm LED lit
22	324	Bypass Overload	Once per 2 seconds	Alarm LED lit
23	325	Maint. Switch Misuse	Once per 2 seconds	Alarm LED lit
24	326	ECU Comm. Error	Once per 2 seconds	Alarm LED lit
25	327	Par. cable abnormal	Once per 2 seconds	Alarm LED lit
26	331	ECU Par. cable abnormal	Once per 2 seconds	Alarm LED lit
27	332	ECU Abnormal	Once per 2 seconds	Alarm LED lit
28	334	BPS Phase Reversed	Once per second	Alarm LED lit
29	354		Once per second	Alarm LED lit
30	335	BPS Unable To Trace	Once per 2 seconds	Alarm LED lit
31	355		Once per 2 seconds	Alarm LED lit
32	336	BPS Not Available	Once per second	Alarm LED lit
33	356		Once per second	Alarm LED lit
34	337	Ecu Set Data Err	Once per 2 seconds	Alarm LED lit
35	353	BPS Par.cable abnormal	Once per 2 seconds	Alarm LED lit
36	357	Bypass Comm. Error	Once per 2 seconds	Alarm LED lit
37	358	Bypass module take over	Once per 2 seconds	Alarm LED lit

4.5 Options

Network Management Card with Environmental Monitoring



CAUTION!

For network management configuration and use, refer to the separate user manual - Network Management Card with Environmental Monitor - shipped with the CARD.

Network Management Card replacement

SNMP card: internal SNMP / external SNMP optional

- ◆ Loosen the 2 torque screws (on each side of the card).
- ◆ Carefully pull out the card. Reverse the procedure for re-installation

The slot called SNMP supports the MEGAtec protocol. We advise that NetAgent II-3 port is also a tool to remotely monitor and manage any UPS system

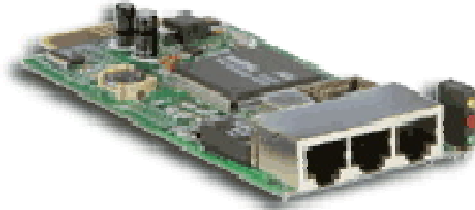

The overview of the SNMP card

NetAgent II-3Ports supports the Modem Dial-in (PPP) function to enable the remote control via the internet when the network is unavailable.

In addition to the features of a standard NetAgent Mini, NetAgent II has the option to add NetFeeler Lite to detect temperature, humidity, smoke and security sensors. Thus, making NetAgent II a versatile management tool. NetAgent II also supports multiple languages and is setup for web-based auto language detection.

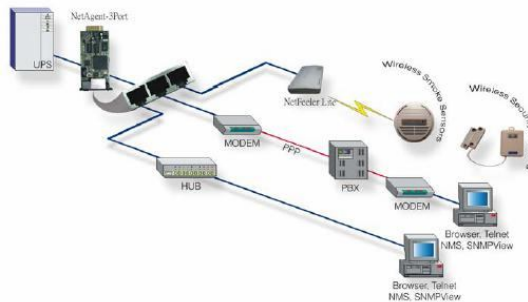

Typical topology of the UPS Network Management

Appendix 1 Specifications

Model		60-90	100-150	200-300	
Capacity	UPS Cabinet	20~90kVA	20~150kVA	20~300kVA	
	UPS Module	20/25/30kVA			
		3	5	10	
Input	Phase		3 Phase 4 Wires and Ground		
	Rated Voltage		380/400/415Vac		
	Voltage Range		138 ~ 485Vac		
	Frequency Range		40Hz-70Hz		
	Power Factor		≥0.99		
	Current THDi		≤3%(100% linear load)		
	Bypass Voltage Range		Max.voltage: 220V:+25 %(optional +10%, +15%, +20%); 230V:+20 %(optional +10%, +15%); 240V:+15 %(optional +10%); Min. voltage: -45% (optional -20%、 -30%)		
			Frequency protection range: ±10%		
	Power Walking In		Yes		
	Bypass back irrigation		Bypass back irrigation		
	Generator access		Yes		
Output	Phase		3 Phase 4 Wires and Ground		
	Rated Voltage		380/400/415Vac		
	Power Factor		1		
	Voltage Regulation		±1%		
	Frequency	Utility Mode	±1%,±2%,±4%,±5%,±10% of the rated frequency(optional)		
		Battery Mode	(50/60±0.1%)Hz		
	Crest Factor		3:1		
	THD		≤2% with linear load, ≤5% with non linear load		
	Efficiency		96%		
	Overload		≤ 110%, to bypass after 60min; ≤ 125%,to bypass after 10min; ≤ 150%,to bypass after 1min		
Battery	Voltage		±180V/192V/±204V/±216V/±228V/±240/±252/±264/±276/±288/±300V dc(30/32/34/36/38/40/42/44/46/48/50pcs optional)		
	Charging Current	UPS Cabinet	30A Max.	50A Max.	100A Max.
UPS Module		10A Max.			
Transfer Time		Utility to Battery : 0ms; Utility to bypass: 0ms			
Protection	Alarm		overload, utility abnormal, UPS fault, battery low, etc		
	Protection		short circuit, overload, over temperature, battery low, fan fault alarm		
Communication Interface		RS232, RS485, Intelligent slot x 2, Dry Contact,SNMP			
Environment	Operating Temperature		0°C ~ 40°C		
	Storage Temperature		-25°C ~ 55°C		
	Humidity		0 ~ 95% non condensing		
	Altitude		< 1500m		
Other	Unit Dimensions(D*W*H)	UPS Cabinet	850x600x1350mm	850x600x1350mm	850x600x2000mm
		UPS Module	620x440x86mm		
	Weight (Kg)	UPS Cabinet	160	170	275
		UPS Module	21		
Standards		EN62040-1, EN62040-2			

Appendix 2 Problems and Solution

In case the UPS cannot work normally, it might be wrong in installation, wiring or operation. Please check these aspects first. If all these aspects are checked without any problem, please consult with local agent right away and provide below information.

- (1) Product model name and serial number, which can be found in LCD display.
- (2) Try to describe the fault with more details, such as LCD display info, LED lights status, etc.

Read the user manual carefully, it can help a lot for using this UPS in the right way. Some FAQ (frequently asked questions) may help you to troubleshoot your problem easily.

No.	Problem	Possible reason	Solution
1	LCD not display	The network cable is not fixed properly or the telephone line of the front door is not fixed properly.	Connect the network cable and telephone cable properly.
2	LCD Blue screen	LCD is Interference	Take out the cable and insert back properly
3	Utility is connected but the UPS cannot be powered ON.	Input power supply is not connected; Input voltage low; The input switch of the module is not switched on.	Measure if the UPS input voltage/frequency is within the window. Check if all modules input are switched on
4	Utility normal but Utility LED does not light on, and the UPS operates at battery mode	The input switch of the Modules are not switched on; input cable is not well connected	Switch on the input switch; Make sure the input cable is well connected.
5	The UPS does not indicate any failure, but output do not have voltage	Output cable does not well connected	Make sure the output cable is well connected.
6	The UPS module cannot transfer to bypass or inverter	Module does not well inserted; The left coronal screw is not tight. Output switch do not switch on	Pull out the module and insert again; Tighten the screw; Switch on the output switch.
7	The UPS module fault LED remains ON	The module is already damaged	Take out this module, replace with a new module.
8	Utility LED is flashing	Utility voltage exceeds UPS input range.	If the UPS operates at battery mode, please pay attention to the remaining backup time needed for your system.
9	Battery LED is flashing but no charge voltage and current	Battery switch does not switch on, or batteries are damaged, or battery is reversely connected. Battery number and capacity are not set correctly.	Switch on the battery switch. If batteries are damaged, need to replace whole group batteries, Connect the battery cables correctly; Go to LCD setting of the battery number and capacity, set the correct data.
10	Buzzer beeps every 0.5 seconds and LCD display "output overload"	Overload	remove some load

11	Buzzer long beeps, LCD display "output short circuit"	The UPS output is in short circuit	Make sure the load is not in short circuit, and then restart the UPS.
12	The LED of the Module with RED light	The module is not inserted properly.	Pull out the module and insert properly.
13	The UPS only works on bypass mode	The UPS is set to ECO mode, or the transfer times to bypass mode are limited.	Set the UPS working mode to Single Module type(non-parallel) or to reset the times of transferring to bypass or re-start the UPS
14	Cannot Black start	Battery switch is not properly closed; Battery fuse is not open; Or Battery low	Close the battery switch; Change the fuse; Recharge the battery
15	Buzzer beeps continuously and LCD indicates Rectifier fault or output fault	UPS is out of order	Consult with your local agent for repair

Appendix 3 CAN communication port definition

Definition of port :

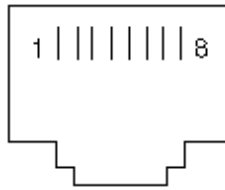

Connection between the Device's CAN coverter port and UPS CAN port.

BMS	UPS (RJ45)	Description
PIN 1	PIN 1	CAN_H
PIN 2	PIN 2	CAN_L
PIN 3/7	PIN 3/7	CAN_GND

Available function of CAN

- ◆ Communicate to BMS.
- ◆ Communicate to remote LCD.

Appendix 4 RS485 communication port definition

Definition of port :

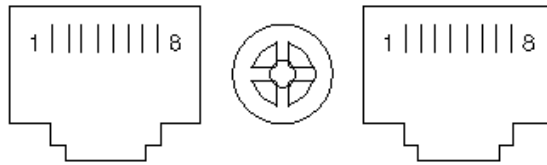

Connection between the Device's RS485 port and UPS RS485 port.

device(RJ45)	UPS(RJ45)	Description
Pin 1/5	Pin 1/5	485+ "A"
Pin 2/4	Pin 2/4	485 - "B"

Available function of RS485

- ◆ Monitor UPS power status.
- ◆ Monitor UPS alarm info.
- ◆ Monitor UPS running parameters.
- ◆ Timing off /on setting.

RS485 communication data format

Baud rate ----- 9600bps
Byte length ----- 8bit
End bit ----- 1bit
Parity check -----none

Appendix 5 COM communication port definition

Definition of port :

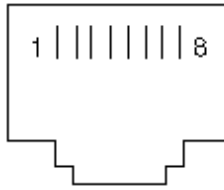

Connection between the Device's RS485 port and UPS COM port.

device(RJ45)	UPS(RJ45)	Description
Pin 1/5	Pin 1/5	485+ "A"
Pin 2/4	Pin 2/4	485 - "B"

Available function of RS485

- ◆ communicate to battery monitor

RS485 communication data format

Baud rate ----- 9600bps

Byte length ----- 8bit

End bit ----- 1bit

Parity check -----none

Appendix 6 LBS port definition

Definition of port:

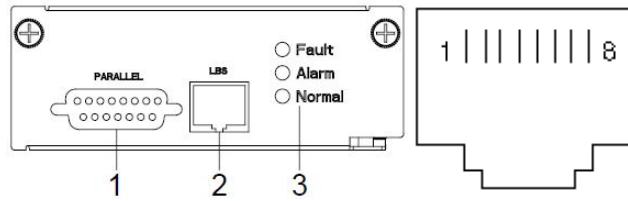

Connection between the UPS LBS port.

UPS(RJ45)	UPS(RJ45)	Description
Pin 1/2/3	Pin 1/2/3	LBS
Pin 5/7/8	Pin 5/7/8	GND

Available function of LBS

- ◆ The output power of two or more UPS in non-parallel system should be synchronized with each other.
- ◆ The output phase of two or more UPS in non-parallel system should be synchronized with each other.

CAUTION!



Two or more LBS cables must be used to form a ring when two or more LBS in non-parallel system. And the cables must use horizontal line.

Appendix 7 REPO instruction

Definition of port:

normally open :

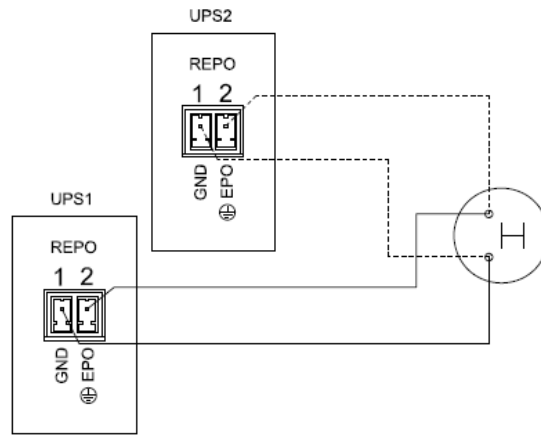

normally close :

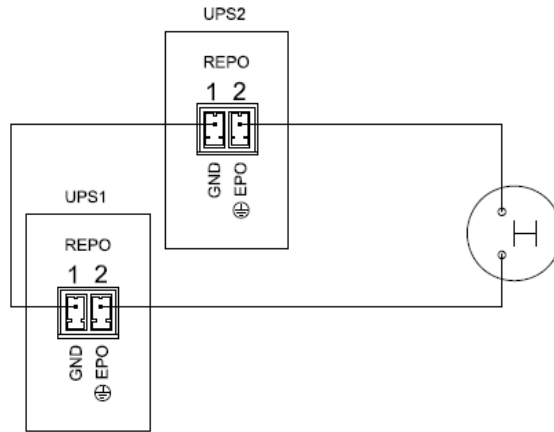

Connection between the button and UPS REPO port.

Button	UPS REPO	Description
Pin 1	Pin 1	GND
Pin 2	Pin 2	EPO

- ◆ In addition to the local EPO push button on the front panel of the UPS (that stops operation of that module when pressed for more than 3 second), the UPS also supports a remote emergency stop (REPO).
- ◆ A remote emergency stop switch (Dry contact signal and “normally open” - not provided) can be installed in a remote location and connection through simple wires to the REPO connector.
- ◆ The remote switch can be connected to several UPS’s in a parallel architecture allowing the user to stops all units at once.
- ◆ Additionally, a second system (not provided) can be connected to the remote switch to disconnect the main input and the secondary (bypass) input sources