

USER MANUAL

10/15/20kVA

Uninterruptible Power Supply

Safety precautions

Operation

1. Before using this product, please read "safety precautions" carefully to ensure correct and safe use, and please keep the manual properly.
2. During operation, please pay attention to all warning signs and operate as required.
3. Do not use the device in direct sunlight, rain or the humid environment.
4. This equipment should not be installed near the heat source area or similar equipment such as electric heater and hot stove.
5. A safe distance and ventilation should be reserved around the UPS. Please refer to the manual for installation.
6. Please use dry cleaning tools for wiping or cleaning the UPS.
7. In case of fire, please use the dry powder extinguisher correctly. There is a risk of electric shock if a liquid fire extinguisher is used.

Electrical safety

1. The battery life is shortened with the increase of ambient temperature. Regular battery replacement can ensure the UPS to work normally and provide sufficient backup time.
2. Battery maintenance can only be carried out by personnel with battery expertise.
3. There is a risk of electric shock and short circuit in the batteries. To avoid personal injury caused by electric shock, please observe the following warnings when replacing batteries:
 - A. Do not wear watches, rings or similar metal objects;
 - B. Use insulated tools;
 - C. Wear rubber shoes and gloves;
 - D. Do not place metal tools or similar parts on the battery.
 - E. Disconnect the load from the batteries before removing the battery connection terminal.
4. Please do not expose the battery to the fire for avoiding explosion and endangering the safety of life.
5. Non-professionals should not open or damage the battery, because the electrolyte in the battery contains dangerous substances such as strong acid, which can cause harm to the skin and eyes. If you accidentally touch the electrolyte, immediately wash it with plenty of water and go to the hospital for examination.
6. Please do not short-circuit the positive and negative poles of the battery, which may cause electric shock or fire.

Use and maintenance

1. The use environment and preservation method have influence on the service life and reliability of this product. Please do not use it in the following working environment:
 - A. High, low temperature and humid places exceeding the technical specifications (temperature 0-40°C, relative humidity 20%-90%).
 - B. Places with vibration and vulnerable to collision.
 - C. Places with metal dust, corrosive substance, salt and combustible gas.
2. If it is not used for a long time, the UPS (without battery) must be stored in a dry environment at the temperature range: -15-60°C. Before starting UPS, the ambient temperature must be warmed to 0°C above and maintained for more than 3 hours.











Content

1. Introduction	1
1.1 Symbol	1
1.2 Rear view	2
1.3 Specification	4
1.4 Electromagnetic compatibility	5
2. Installation	6
2.1 Unpacking inspection	6
2.2 Power cable selection	6
2.3 External circuit breaker selection	6
2.4 UPS connection	7
2.5 Connection to the computer	8
3. Control Panel	9
3.1 Panel display	9
3.2 Function of button	10
3.3 LED Indicator	10
3.4 Audible Alarm	11
3.5 UPS working status table of LCD display	11
3.6 Parameter query	12
3.7 Function setting	13
4. Fault code and solution	15
5. Control and communication	17
5.1 SNMP Card	17
5.2 Dry Contact	17
5.3 EPO	18
6. Battery Maintenance & Repair	19

1. Introduction

This series of UPS is an online sine wave uninterruptible power supply system with bypass maintenance switch, which can provide reliable and high-quality AC power for your precision equipment. It can be used in a wide range, from computer equipment, communication system to industrial automatic control equipment. Because of its online design, it is different from the backup ups. It continuously adjusts and filters the input voltage. When the power supply is interrupted, it will provide the backup power from the backup battery without time interruption. In case of overload or inverter failure, the UPS switches to the bypass state and be powered by the mains. If the overload is cleared, the UPS will automatically switch back to the inverter power supply state.

1.1 Symbol

Symbols and Meanings	
Symbols	Meanings
	Attention
	Danger
	AC (alternating current)
	DC (direct current)
	Protective earth conductor
	Protective connecting conductor
	Loop
	Do not place with sundries
	Overload
	Battery
	ON/OFF Switch

1.2 Rear view

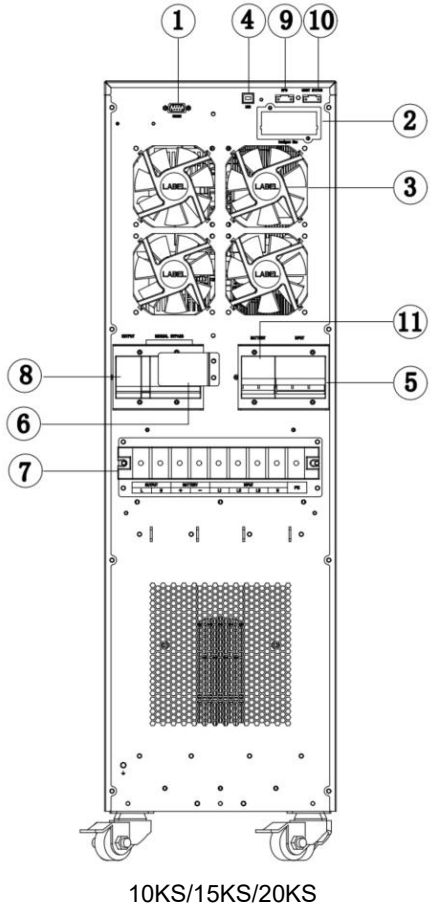
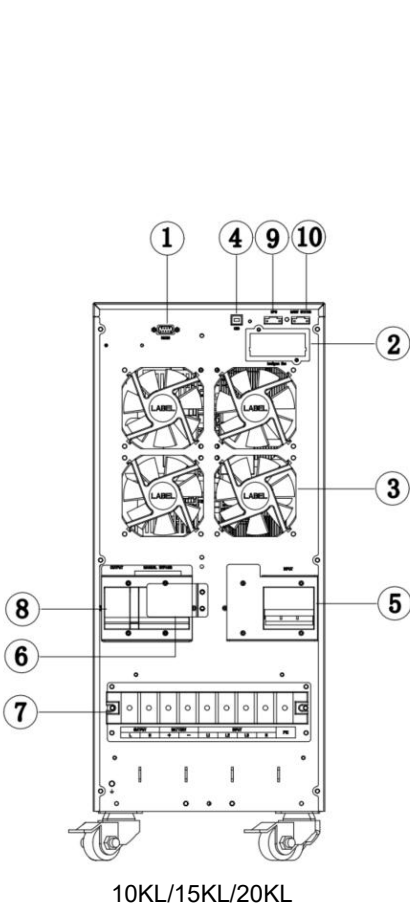

① RS232 port

② Smart slot

③ Fan

④ USB Port

⑤ Input breaker

⑥ Maintenance bypass switch

⑦ Terminal block

⑧ Output breaker(optional)

⑨ EPO

⑩ Maint status port

⑪ Battery breaker

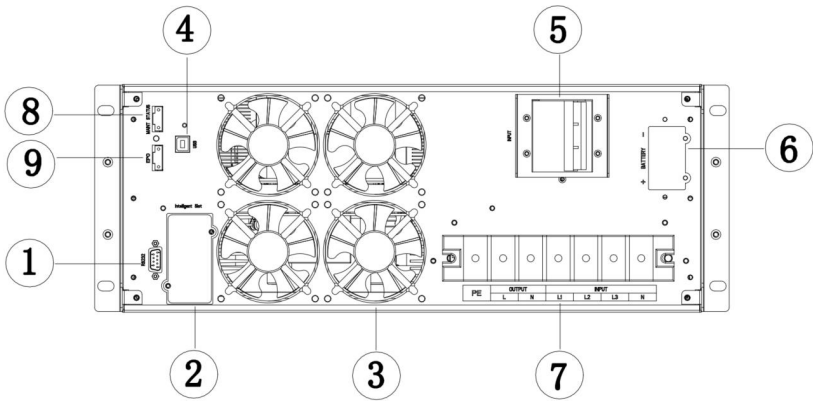

10KL/15KL/20KL

- ① RS232 port
- ② Smart slot
- ③ Fan
- ④ USB Port
- ⑤ Input breaker
- ⑥ External battery connection port
- ⑦ Terminal block
- ⑧ Output breaker(optional)
- ⑨ EPO

1.3 Specification

Model	10KS	10KL	15KS	15KL	20KS	20KL
Capacity	10kVA/10kW		15kVA/15kW		20kVA/20kW	
Input						
Nominal Voltage	208/220/230/240VAC(L-N), L+N+PE or 3Ph+N+PE					
Voltage Range	100-300VAC(L-N)					
Frequency Range	40-70Hz					
Power Factor	> 0.99					
Output						
Nominal Voltage	208/220/230/240VAC, L+N+PE					
Voltage Regulation	±1%					
Frequency	50/60Hz±0.1% (Battery Mode)					
Crest Ratio	3:1					
THDu	≤2% (linear load); ≤7% (non-linear load)					
Transfer Time	Line mode to battery mode,0ms; inverter to bypass ,4ms					
Waveform	Pure sine wave					
Overload Capacity	105%-125% load, 10min; 126-150% load, 1min; > 150% load, 100ms					
Efficiency						
Line Mode	93%					
Battery Mode	92%					
ECO Mode	98%					
Battery						
Battery Type	Sealed lead acid maintenance free					
Battery Voltage	192VDC/240VDC					
Battery Number	9Ah*16	External	7Ah*16*2	External	9Ah*16*2	External
Charging Current	2A	4A or 8A	2A	4A or 8A	2A	4A or 8A
Management						
Intelligent port	RS232/USB/SNMP card (optional)/Dry contact card (optional)					
Environment						
Operation Temperature	0-40℃					
Relative Humidity	0-95%(non-condensing)					
Noise	< 55dB@1 meter away					
Altitude	Up to 1000m without derating					

Note: if the altitude exceeds 1000 meters, the UPS should be derated, please refer to the table of derating factors below.

Altitude(m)	1000	1500	2000	2500	3000	3500	4000
Derating factor	100%	95%	91%	86%	82%	78%	74%

1.4 Electromagnetic compatibility

Safety	
IEC/EN 62040-1-1	
EMI	
Conducted Emission.....IEC/EN 62040-2	Class A
Radiated Emission.....IEC/EN 62040-2	Class A
EMS	
ESD.....IEC/EN 6100-4-2	Level 4
RS.....IEC/EN 6100-4-3	Level 3
EFT.....IEC/EN 6100-4-4	Level 4
SURGE.....IEC/EN 6100-4-5	Level 4
Low Frequency Signals.....IEC/EN 6100-2-2	
Warning: This is a product for commercial and industrial application in the second environment-installation restriction or additional measures may be needed to prevent disturbances.	

NOTICE:

Operate the UPS in an indoor environment only in an ambient temperature range of 0-40°C (32-104°F). Install it in a clean environment, free from moisture, flammable liquids, gases and corrosive substance.

This UPS contains no user-serviceable parts except the internal battery pack. Under no circumstance attempt to gain access internally, due to the risk of electric shock or burn. Do not continue to use the UPS if the panel indications are not accordance with these operating instructions or the UPS performance alters in use. Reflect all faults to your dealer.

Servicing of batteries should be performed or supervised by persons who has knowledge and experience of servicing batteries.

Keep unauthorized persons away from the batteries. Proper disposal of batteries is required.,refer to your local laws and regulations for disposal requirement.

DO NOT CONNECT equipment that could overload the UPS or demand DC current from the UPS, for example: electric drills, vacuum cleaners, laser printers, hair dryer or any appliance using half-wave rectification.

Storing magnetic media on top of the UPS may result in data loss or corruption.

Turn off and isolate the UPS before cleaning it. Use only a dry cloth, never liquid or aerosol cleaners.

2. Installation

 Warning: To ensure safety, please pay attention to cut off the AC breaker before installation. The battery breaker also need to be cut off, if its a long backup time model.

 Caution:

1. Installation and wiring must be performed by professional personnel in accordance with local regulations.
2. The UPS needs to connect to the ground.

2.1 Unpacking inspection

Inspect the appearance of the UPS to see if there is any damage during transportation. Do not turn on the unit and notify the carrier and dealer immediately if there is any damage or lacking some parts.

 Recycling: The packing boxes are recyclable, so please keep them well for using in the future.

2.2 Power cable selection

 Attention: Power cables should be multiple strands of copper core wires, refer to the requirement to the cross- sectional area of cables below, and the terminal bolt is M6.

A) For single phase input and single phase output

UPS capacity	Input	Output	Battery	Earth wire
10kVA	10mm ²	10mm ²	10mm ²	10mm ²
15kVA	16mm ²	16mm ²	16mm ²	16mm ²
20kVA	25mm ²	25mm ²	25mm ²	25mm ²

B) For 3-phase input and single phase output

UPS capacity	Input	Output	Battery	Earth wire
10kVA	6mm ²	10mm ²	10mm ²	10mm ²
15kVA	6mm ²	16mm ²	16mm ²	16mm ²
20kVA	10mm ²	25mm ²	25mm ²	25mm ²

2.3 External circuit breaker selection

The external circuit breakers are recommended in the below table.

UPS capacity	Input		Output	Battery
	Single phase	3-phase		
10kVA	63A	32A	63A	63A
15kVA	100A	32A	80A	100A
20kVA	125A	40A	100A	125A

2.4 UPS connection

1. Confirm the external input breaker, the external output breaker and the external battery breaker are disconnected.
2. Remove the terminal cover box on the rear of the UPS, and connect the power cables to the terminal according to the identification of the terminal.
3. Confirm all cables are correctly and well connected, and reinstall the cover box.

Terminal block diagram:

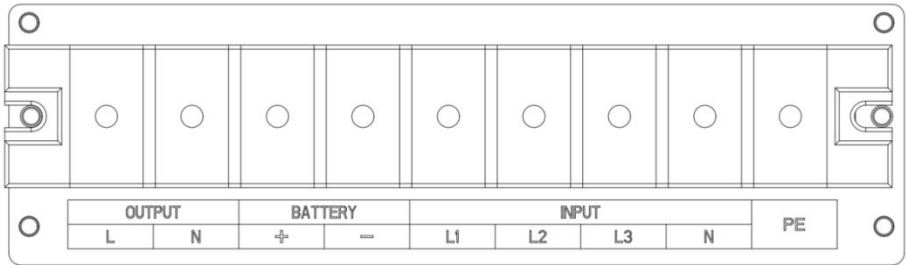

3-phase input / single phase output

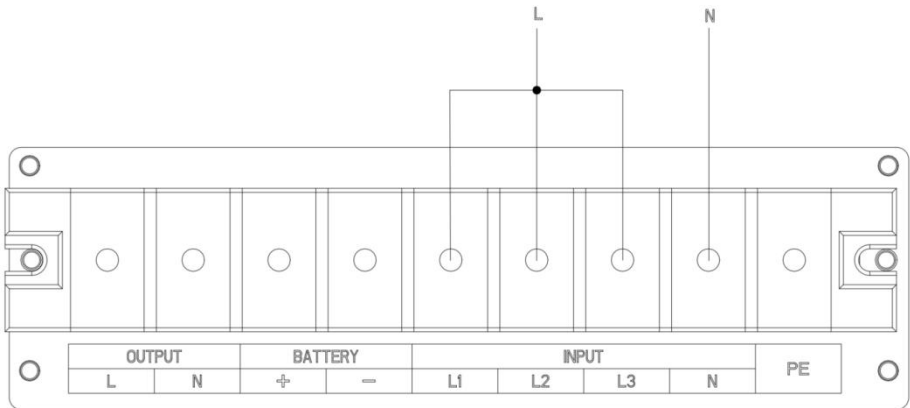

Single phase input/ single-phase output

Note: The UPS supports 3/1(3-phase input/single phase output) and 1/1(single phase input/single phase output) configurations, if needing 1/1 configuration, please shorted L1, L2 and L3 with the cables.

2.5 Connection to the computer

RS232: Using RS232 to connect UPS with the monitoring equipment

1. Use RS232 communication cable to connect to the computers RS232 port first.
2. Then use the other terminal of RS232 to connect to the RS232 port of UPS.

USB: Using USB to connect UPS with the monitoring equipment

1. Use USB communication cable to connect to the computers USB port first.
2. Then use the other terminal of USB to connect to the USB port of UPS.

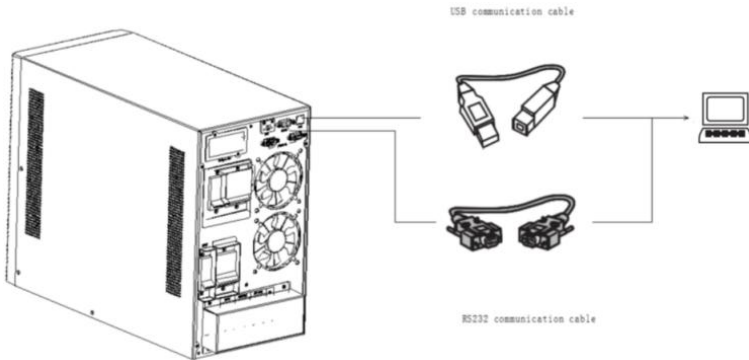

RS232 interface on UPS:

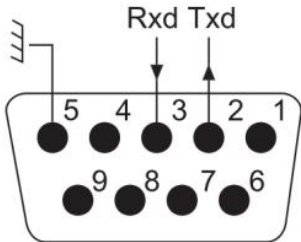

Note: USB port and RS232 port cannot work at the same time.



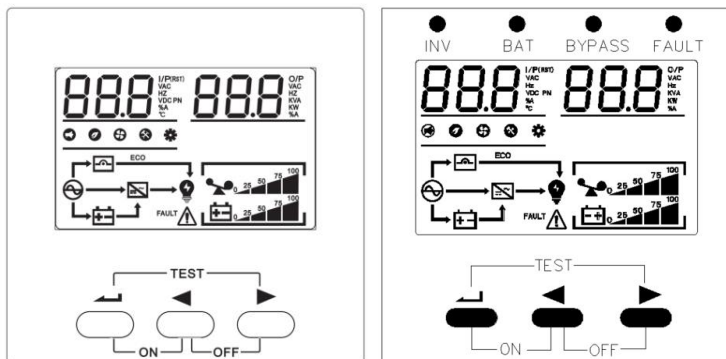

3. Control Panel

3.1 Panel display



Display	Function
Error message	
FAULT	Failure occurred
	Warnings
BB	Fault code
Mute	
	Mute function
Input and output voltage, DC voltage, UPS internal temperature	
88.8 <small>VAC</small>	VAC: input and output voltage; VDC: DC voltage °C: UPS internal temperature; Hz: Frequency
Load information	
	The load volume(0-25%, 26%-50%, 51%-75%, 76%-100%) is shown here, and the overload icon flashes when the battery is low or not connected
Battery information	
	The battery capacity(0-25%, 26%-50%, 51%-75%, 76%-100%) is displayed separately, and the battery icon flashes when the battery is low or not connected
Other information	
	AC
	Battery
	Bypass
	Inverter
	Output working
	Fan status: LED will always be on when the fan is normal, and flashes when the fan fails
	Setting icon: when entering the setting menu, the icon will light up, and the icon is not shown in the other cases
	ECO function: the icon light up when ECO-function is used, otherwise the icon is not displayed

3.2 Function of button

Button	Functional Description
Combo key for turning on the UPS and exiting setting ()	<p>AC Mode: press the two buttons at the same time for 1 second above to start UPS.</p> <p>Battery Mode: please press (↕) confirmation button first, after turning on the screen, please press the two buttons at the same time for 1 second above to start UPS.</p> <p>Exiting setting: After completing the parameter setting, press the two buttons for 1 second to exit the setting.</p> <p>Note: Only when the battery group has been connected, UPS can be turned on.</p>
Combo key for turning off the UPS ()	<p>AC Mode: press the two buttons at the same time for 1 second above to turn off the inverter, the system will turn to Bypass Mode.</p> <p>Battery Mode: press the two buttons at the same time for 1 second above to turn off the inverter, and after 1 minute, the system will shut down, and the screen will turn off.</p>
Combo key for self-checking and mute function ()	<p>Testing: in AC Mode, press the two buttons at the same time for 2 seconds above to test the battery.</p> <p>Mute: in Battery Mode/Alarm/Testing Mode, press two buttons at the same time for 2 seconds above to erase alarms, press two buttons again for 2 seconds above to recover alarms.</p>
Function setting /confirmation key ()	<p>Function setting: press the key more than 2 seconds to enter the function setting page, after completing the setting, press the key more than 2 seconds again to return to the main page.</p> <p>Confirmation: in the function setting page, press the confirmation key 1 to 2 seconds to confirm the setting options.</p>
Page turning ()	<p>Page turning: press ◀ or ▶ key 1 to 2 seconds to turn to left or right page.</p>



3.3 LED Indicator

Indicator	Colour	Instruction
INV	Green	ON: UPS working in Line Mode OFF: UPS not working in Line Mode
BAT	Yellow	ON: UPS working in Battery Mode OFF: UPS not working in Battery Mode Flickering: Battery voltage low
BYPASS	Yellow	ON: UPS working in Bypass Mode OFF: UPS not working in Bypass Mode Flickering: Bypass abnormal
FAULT	Red	ON: fault; OFF: Normal; Flickering: Alarm

3.4 Audible Alarm





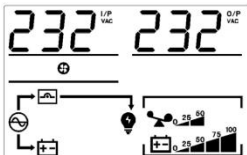

Buzzer alarms	Description
Continuous beeping	Fault
Sounding every one second	Battery voltage low
	Overload
Sounding every two minutes	Bypass mode
Sounding every four seconds	Other alarms except the above

3.5 UPS working status table of LCD display

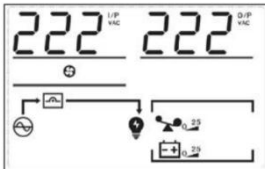
AC Mode	
LCD display content	Instruction
	<p>UPS can provide stable AC output when AC input in the permissible range. In AC Mode, batteries will also be charged by the UPS.</p>
Battery Mode	
LCD display content	Instruction
	<p>When the AC input is out of limited range or shut off, the UPS will turn to Battery Mode. The batteries supply the inverter and have beep every 4 seconds.</p>
Bypass Mode	
LCD display content	Instruction
	<p>When the AC input keeps normal, start the bypass mode and close the UPS on the panel. The UPS will turn to Bypass Mode, and give out beep sound every 2 minutes.</p>

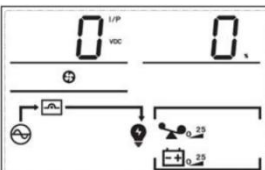
3.6 Parameter query

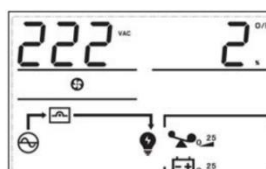
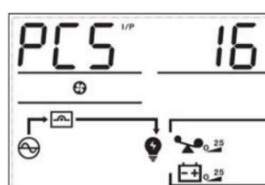
Normally the LCD display can show 8 pages totally. Pressing the query button ◀ or ▶ for 0.1-2 sec can enter into the different pages which show all information, such as input, battery, output, load, software version, temperature, and etc. If alarms occur, the display will add one more page to show the alarm information. If the UPS has faults, the default display will turn to the Fault code page automatically, the home page will show the fault or alarm information by default. When UPS keeps normal working, the home page default display will show the input voltage and the output voltage information.

LCD Display 1: UPS input & output voltage	LCD Display 2: UPS input & output frequency
	
LCD Display 3: Battery voltage and capacity	LCD Display 4: Output voltage and output active power
	
LCD Display 5: Output voltage and output apparent power	LCD Display 6: Output voltage and load percentage
	
LCD Display 7: Quantity of batteries connected	LCD Display 8: Fault code
	

3.7 Function setting

When setting parameters, please first transfer UPS to the bypass mode, otherwise, it cannot enter into the setting screen.

01: Output voltage

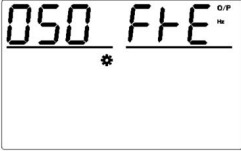
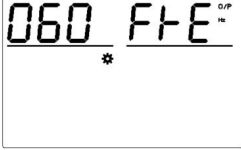

LCD Display	Setting
	<ol style="list-style-type: none"> 1. Press the function setting button (↵) for over 2 sec, then it goes to the setting page. Press the page turning buttons till the setting page of output voltage, note the selectable voltage values are 208/220/230/240Vac. 2. Press confirmation button (↵) for 1 sec for confirming the setting. 3. Press the two buttons (↵) and ◀ for 1 sec, exit the setting page and back to the home page. (Or no operation, waiting more than 60 sec, the page will come back to home page automatically). <p>Note: When the output voltage setting with 208V, the output needs to decrease to 90% of rated power.</p>

02: Output frequency

LCD Display	Setting
 	<ol style="list-style-type: none"> 1. Press the function setting button (↵) for over 2 sec, then it goes to the setting page. Press the page turning buttons till the setting page of output frequency, note the selectable frequency values are 50/60Hz. 2. Press confirmation button (↵) for 1 sec for confirming the setting. 4. Press the two buttons (↵) and ◀ for 1 sec, exit the setting page and back to the home page. (Or no operation, waiting more than 60 sec, the page will come back to home page automatically).

03: Other functional setting

03-1: Economic Operation Mode

LCD Display	Setting
	ECO is OFF by default, can be set as ON to improve the efficiency of system operation.
	

03-2: Emergency shut down(EPO)

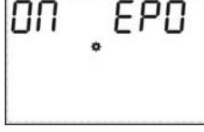
LCD Display	Setting
	Emergency shutdown can be set as closed or open to trigger, the default is open to trigger. Note: After EPO action, emergency shutdown, close all outputs immediately.
	

03-3: Battery quantity(PCS)

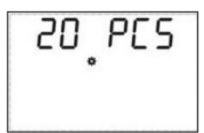
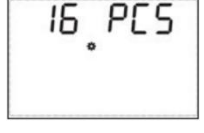
LCD Display	Setting
	When EP is set to ON, the PCS option appears on the function setting page, will enter the password page, enter the password (the general password is 135), you can set the number of batteries. The default battery number is 16pcs,which can be set to 20pcs.
	

4. Fault code and solution

When the "FAULT" is long bright, and "△" symbol on the UPS LCD flashes, the UPS is in fault state. UPS automatically switches to the error status page (refer to 3.5) to observe the fault code and make appropriate processing according to the following table.

Fault	Description	Solution
01	UPS start up not success	Battery Low
		UPS internal failure, please contact the distributor for service.
02	Internal DC BUS over-voltage protection	Half-wave rectifier load(hair dryer , half-wave solenoid valve , energy re-generated type load (motor, huge transformer, capacitor with residue charge, remove this kind of load and turn on the UPS again.
		Over mains voltage, turn on the UPS again.
		UPS internal failure, please contact the distributor for service.
03	Internal DC BUS under-voltage protection	Battery Low or overload
		UPS internal failure, please contact the distributor for service.
10	UPS Output Short-Circuit	Remove short-circuit equipment from UPS
22	UPS Over Load	Reduce loading capacity below UPS rating
23	UPS Over Temperature	Make sure UPS should work in ambient of -10-45oC, if the ambient temperature can't meet this spec. Try reduce loading
		Check ventilation inlet of the UPS ON from panel and outlet on the rear panel is not blocked
		UPS internal failure, please contact the distributor for
29	UPS Input rectifier protection	Low input voltage and overload
		UPS Internal failure, please contact distributor for service
57	Battery UN-connected	Check battery input wiring and battery cutoff device such as circuit breaker etc.

59	Charger Fail	UPS Internal failure, please contact distributor for service
60	EPO activated	Reset the External EPO switch, if no EPO switch install, turn off EPO function via the operating panel
Battery Icon Flashing		Battery not connected or battery low
		Charger failure, Contact distributor for service
UPS not working normal line mode with normal mains input		Make sure Input circuit breaker is ON
		Turn on the UPS via ON/OFF button
Backup time is not as long as expected		Battery low, recharge the battery long enough time
		Overload, reduce the loading
		Battery aged, please contact distributor for service
UPS not turn ON after pressing ON/OFF button		Press the ON/OFF button long enough time , 3seconds , and hear a buzzer beep for acknowledging the correct TURN ON operation
		Battery low or not connected
		UPS Internal failure, please contact distributor for service

5. Control and communication

UPS includes several communication ports: RS232,EPO,SNMP card, USB, and dry contact card.

NOTICE: Only one of SNMP card, and dry contact card can be used at the same time. Only one of RS232 and USB is available at the same time.

5.1 SNMP Card

SNMP card is used to monitor the UPS via TCP/IP protocol, users can check the UPS status and data online. Please refer to the user manual of SNMP card to get more detailed information.

5.2 Dry Contact

There are two types of dry contact for option: DB9, phoenix terminal.

Maximum output current for dry contact is 1A. The function of dry contact is listed as below:

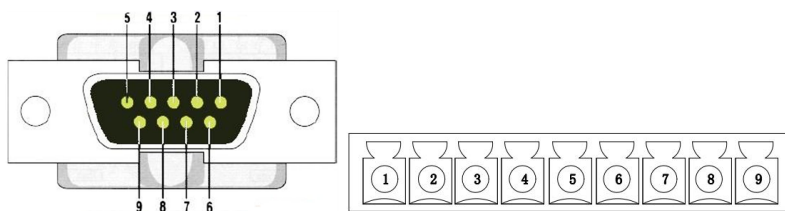

DB9 port

Phoenix terminal

Function	DB9	Phoenix	Description
UPS fault	1	1	Open from common connection: UPS is abnormal. Closed: UPS is normal.
General alarm	2	2	Open from common connection: UPS is warning Closed: UPS is normal.
GND	3	3	Internal GND, used to connect external power supply 12-24Vdc
Remoted shutdown	4	4	Input port. Used with external power supply. If connected to power supply, UPS transfer to bypass. UPS shutdown if bypass is abnormal.
Common connection	5	5	Common connection of output signal. Connected to power supply for input signal.

Bypass mode	6	6	Closed to common connection: UPS is working in bypass mode. Open: UPS is not working in bypass mode.
Battery low	7	7	Open from common connection: battery low alarm Closed: battery capacity is normal or not in battery mode
Normal mode	8	8	Closed from common connection: UPS is working in normal mode.
Utility failure	9	9	Open form common connection: utility input fails.

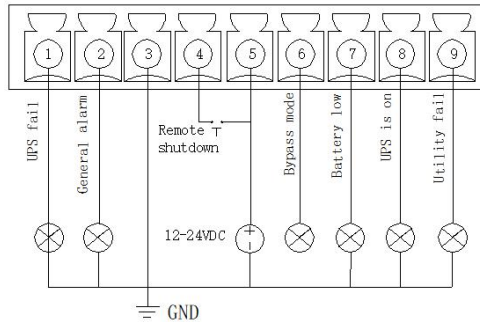
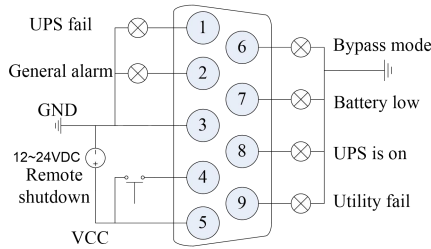

5.3 EPO

The remote EPO is located on the rear panel of UPS. Its normal closed, if its open, it will active EPO function, the UPS will shutdown output.

6. Battery Maintenance & Repair

- (1) This series of UPS only needs very little maintenance. The batteries of the standard machine are seal type and no need to maintain frequently. But also keep charging to get the expected battery life. UPS keeps charging when it is connecting to AC, no matter on/off. And if also have function of over charging and overload protection.
- (2) If you do not use UPS for a long time, you should charge the UPS every 4-6 months. In the area of high temperature, battery should be charging and discharging every two months, the charging time should not be less than 12 hours.
- (3) In normal circumstances, service life of the battery is 3-5 years, if the battery is found to be in poor condition, it must be replaced in advance. When replacing the battery, it must be done by a professional.
- (4) When replacing the battery, follow the principle of quantity and model consistent.
- (5) The battery should not be replaced individually and when it replaced as a whole should be according to the battery suppliers instructions.
- (6) In normal circumstances (under the condition of UPS with little back up power), the battery should be charged and discharged every 4-6 months. Keep discharging before UPS shut down then keep charging. The standard machine charging time should not be less than 12 hours.

Product are subject to change without notice.