

HS-FMF Mechanical High Speed Filter



LOREN INDUSTRY CO., LTD
WA: +86-13921106199/13952466865
Mail: Lorenindustry@163.com
Web: www.Lorenindustry.com

1. HS-FMF Filter Brief Know-How

Fully Automation and Ultra High Speed Filter

(HS-FMF Filter) is a large-capacity filtering equipment that can perform ultra-high-speed processing operations.

It makes up for the shortcomings of filters commonly used in China and greatly improves the filtration efficiency. It is a new type of water filter with main purpose of removing SS and suspended matter. Our company has successfully applied for a national patent for this filter .

2. FMF Filter Structure

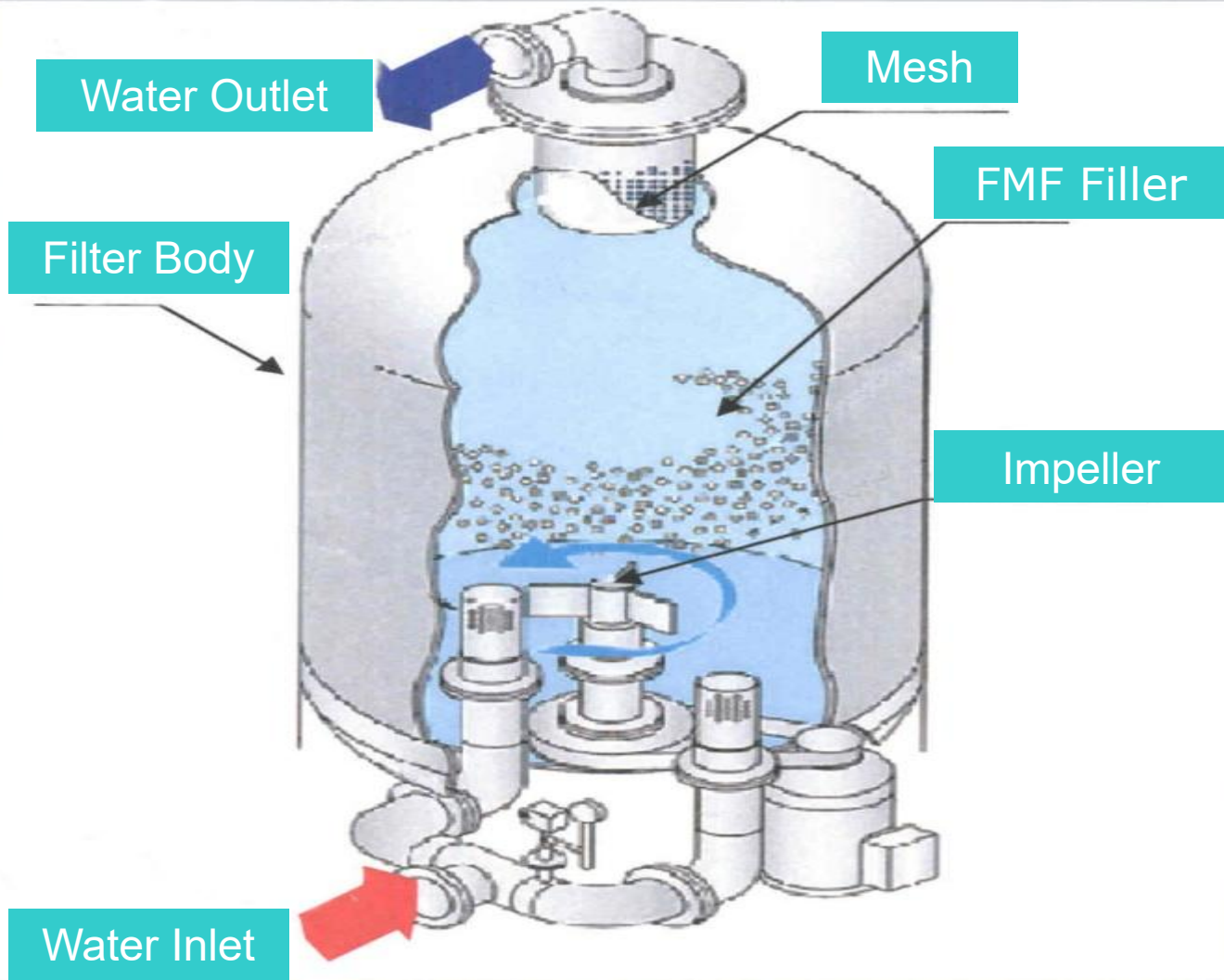

3. FMF Filter Packing

Shape :Multiple Angle Floatable FMF Filter Module

Dimension: 5mm*5mm*3mm

Material :(PP)、 (PS)

Pore Diameter : ϕ 5-70 μ m

Rate of the Nurgle:

Specific Surface Area :

Porosity : 90-94%

Specific Gravity : 0.85-0.95

10Kg-SS/m³

8000m²/m³

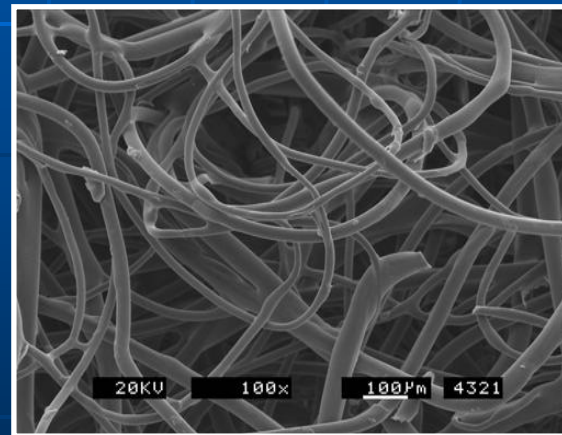

4. FMF Filter Working Principle

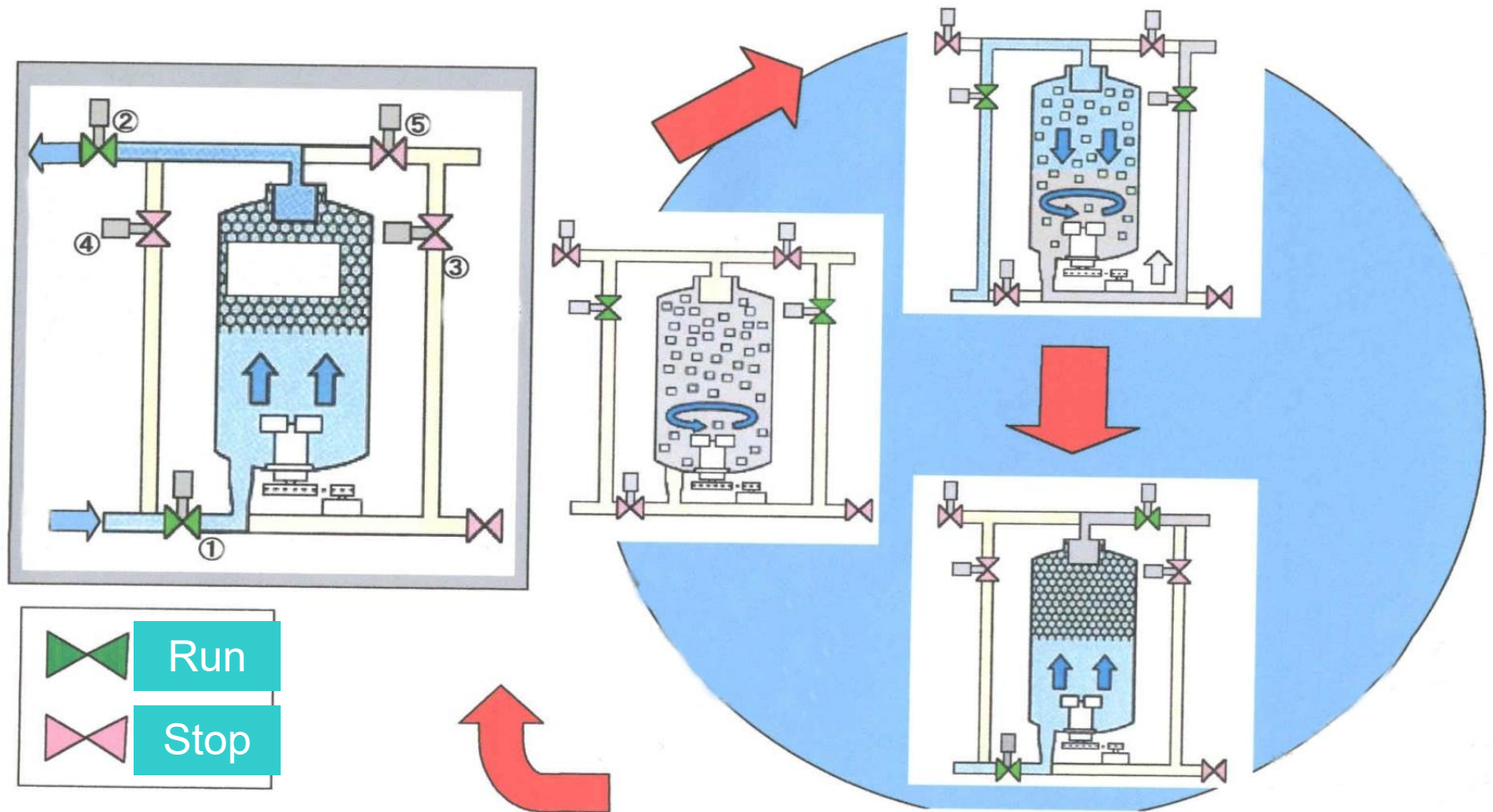

① Filter Water Inlet Valve
④ Flush Water Inlet Valve

② Purified Water Outlet Valve
⑤ Flush Process Water Discharger Valve

③ Flush Water Outlet Valve

5. FMF Filter Applicant Range

It Has a Wide Range of Applicant in Below Field:

- ★ Sewage Treatment Plant Depth Treatment
 - ★ Gray Water & Swimming Pool Water Treatment
 - ★ River Water, Lake Water And Rain Water Treatment
 - ★ water Works filtration treatment
 - ★ Aquaculture Water Purification Treatment
 - ★ Industrial Wastewater Recycling Filtration Treatment
 - ★ Cooling Circulating Water Treatment
- But Not limited to Above

6. FMF Filter Feature

1) The Filter Module is Fluid with Flowing Performance

Granular FMF filter Module Fits for All kinds of Filter (Upflow ,Downflow etc.)

2) Time and Water Saving for Agitating and Backwashing

Its backwashing Water Volume is 1/20 of the Traditional Water Flow Method to Maximize Reduction of Water Consumption Backwash Time:8-9 Minutes/Cycle Per Day

3) Excellent Deep Filtration Efficiency

The 3D Pore FMF Filter Module Forms a 1000 mm Filter Layer to Achieve Deep Filtration. The Best Filtering Performance Whose Duration Depends on its Filter Module Volume

4) FMF Filter Filtration Module Has Three-Dimensional Porosity

It Can Reduce Pressure Lost and Save Energy , Its Maximum Feature is its Super Higher Filtration Speed

(For Low Voltage FMF Filter : 40-70 m/h; For Quartz Sand Filter : 10-15 m/h)

5) Compact Structure

No Need Configure Other Separated Backwash Pump Or Storage Device , so it occupy very Small Room With Light Weight :Compared with Sand Filter: Whose Body is 1/8; DN is 2/5 and Room is 1/4 of that Sand Filter .

Footprint Comparison with Quartz Sand Filter

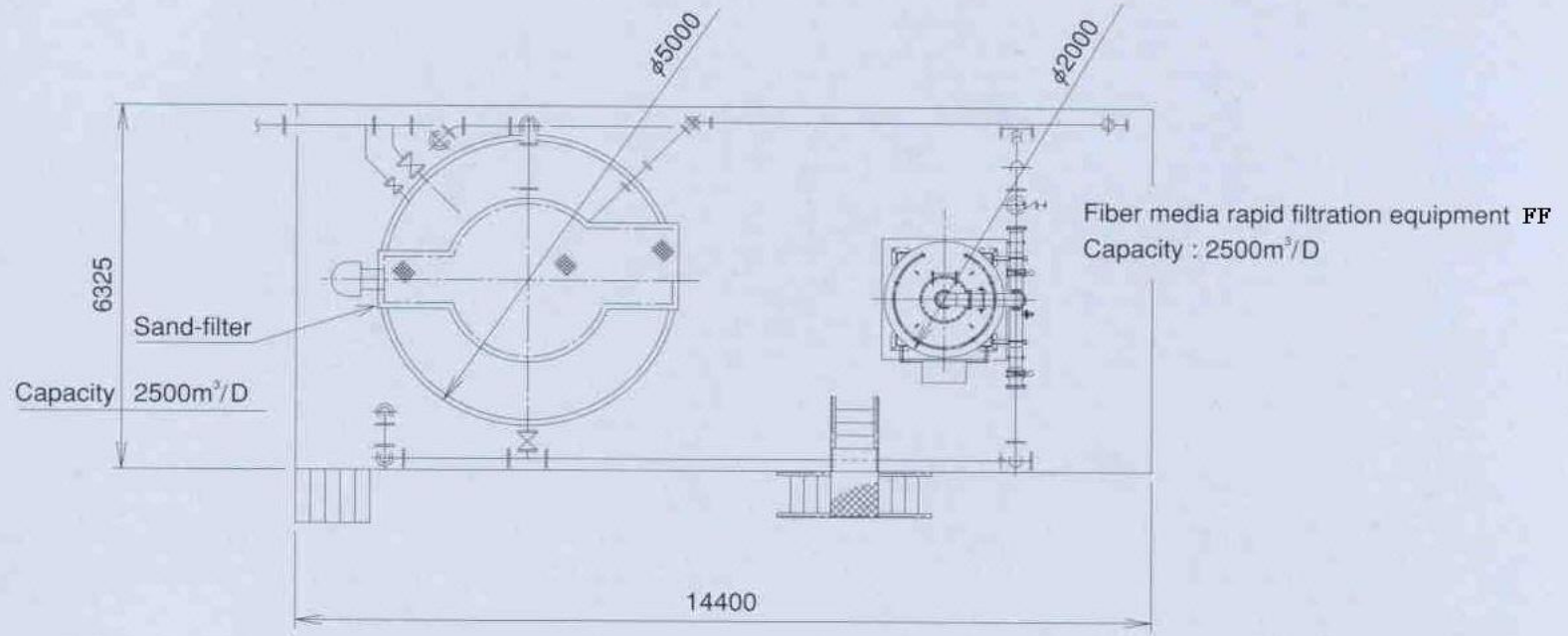

7. Several Filter Speed Comparison

Filter Item	Filter Speed
Conventional Filter	8~12 m/h
UF	10~15 m/h
FMF Filter	40~70m/h

8. Filler Comparison Between FMF Filter and Quanz Sand Filter

	Quartz Sand Filler	PP Filler
Effective Grain Diameter	Between 0.6mm and 4mm	5*5*3mm
Porosity Ratio	About 0.4	About 0.94
Specific Surface Area	6,000 M2	8,000 M2
Filler Layer Thickness	1 Meter	1 Meter
SS Catch Volume	4 Kgs-SS	10 Kgs-SS

※ Large Porosity Can Lead to Large Capacity. The 3D Porous Structure Can Be Used for Deep Filtration with Large Amount Suspend Solid Capture Performance.

9. Comparison Among Large Filters

Date	V-Shape Filter	Fiber Bundle Filter	D-Shape Filter Pool	Fiber Turntable Filter	Flap Filter	High Speed FMF Filter
Speed (m/h)	7-15	18-20	20-26	9-12	6-10	40-70
Filler Layer Thickness (m)	1.2-1.5	0.8-1.2	0.8-1.2	—	1.5	1
Accuracy (μm)	15	10	5	10	15	1
Backwash Time and Period	20min (24h)	15-20min (24h)	15-20min (8-24h)	1-2min (1-2h)	20min (36h)	8min (24h)
Backwash water accounts for % of daily treatment	5-6	2-5	5-9	5-7	5-6	0.5 (Raw Water Flush)
SS Removal Ratio %	70-90	80-90	90-95	90-95	70-80	Over 98
Cost per Ton Water	100-120 ¥	75-85¥	100¥	85-100¥	120-150¥	85¥
Foot Print (50000 M3)	200m2	165m2	100m2	80m2	240m2	75m2

10.FMF Filter Specification

Specification	FMF-10	FMF-20	FMF-40	FMF-80	FMF-120	FMF-200
Capacity (m ³ /h)	20	40	70	140	210	350
Agitator (Kw)	1.5	3.7	5.5	11	18.5	30
Diameter (mm)	600	850	1150	1600	2000	2600
Height (mm)	2600	2705	3035	3320	3725	4200
Net Weight (Kg)	680	935	1550	2650	4250	6000
Inlet & Outlet Water Pipe	DN65	DN80	DN100	DN150	DN200	DN250
Power Supply	110/220/380/400/415/460/480 V, 3ph/1ph, 50/60Hz					
Auto Valve	Electric Butterfly Valve					

11.FMF High Speed Filer Performance Site List 1



600M3/D WWTP SS Purifier



600M3/D Industrial WWTP

11.FMF High Speed Filer Performance Site List 2



**2800M3/D Electronic Plant
Water Purification**



4500M3/D Deep WWTP

11.FMF High Speed Filer Performance Site List 3



4000 M3/D Chemical WWTP



100 M3/D WWTP