

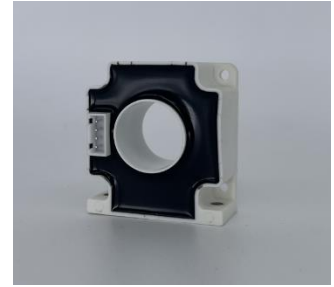

Flux Gate Current Sensor DXE200-210-G

$I_{PN} = 200\text{ A}$

The DXE200-210-G is an advanced flux gate current sensor that uses high technology to bring the best combination of performance and reliability. It is rated for a primary current measurement range of $\pm 200\text{ A}$ dc. It is calibrated and temperature compensated for improved accuracy using multi-point temperature characterization.



DIFFERENTIATION

- Accuracy: Multi-point temperature characterization and calibration for improved accuracy over temperature range.
- Magnetic immunity: Flux gate configuration and optimized magnetic circuit allow for excellent performance in diverse magnetic environments.
- Flexible: Customizable on-board firmware to meet specific application requirements.

Features

- Excellent accuracy
- Very good linearity
- Low temperature drift
- Wide frequency bandwidth
- Optimized response time

Application Domain

- Metrological verification and calibration
- Laboratory current measurement
- Instrumentation (e.g. power analyzer)
- Medical equipment, such as magnetic resonance imaging (MRI)
- Battery pack detection
- Power control



Electrical data

Parameter	specifications			Condition
	Minimum value	Standard value	Maximum value	
Rated input current I_{PN}		± 200 Adc		/
Measure range I_{PM}			± 220 Adc	1Min/Hour
Power supply voltage V_C	± 12 Vdc		± 15 Vdc	Full range
Current consumption I_C	± 20 mA	± 120 mA	± 220 mA	I_{PM} range
Current change K_N	1000:1			Input : Output
Rated output current I_{SN}		200 mA		Rated input current
Measuring resistance R_M			40 Ω	

Accuracy- Dynamic Parameter

Project	Symbol	Test conditions	Numerical value			Unit
			minimum	standard	maximum	
Accuracy	X_e	25 \pm 10 $^{\circ}$ C	--	--	100	ppm
Ratio error	X_{Ge}		--	--	100	ppm
angle error	X_{Pe}		--	--	0.01	crad
Linearity	ϵ_L	--	--	--	100	ppm
Temperature drift coefficient	TCl	--	--	--	1	ppm/K
Time drift coefficient	TT	--	--	--	1	ppm/month
Power supply anti-interference	TV	--	--	--	1	ppm/V
Zero offset current	I_o	25 \pm 10 $^{\circ}$ C	--	--	0.01	mA
Zero offset current	I_{oT}	Within the full operating temperature range	--	--	± 0.01	mA
Ripple current	I_n	DC-10Hz	--	--	0.5	ppm
Dynamic response time	T_r	di/dt=100A/us	--	--	1	us
		rise to 90% I_{PN}				
Current following speed	di/dt	--	100	--	--	A/us
Bandwidth(- 3 dB)	F	--	0	--	10	kHz



General characteristics

Project	Symbol	Test conditions	Numerical value			Unit
			minimum	standard	maximum	
Operating temperature range	T _A	--	-40	--	85	°C
Storage Temperature Range	T _S	--	-40	--	85	°C
Weight	m		100g			g

Safety characteristics

Project		Symbol	Test conditions	Numerical value			Unit
				minimum	standard	maximum	
Withstand voltage	Between primary and secondary edges	V _d	50Hz,1min		3		KV
Transient isolation withstand voltage	Between primary and secondary edges	V _w	50us		5		KV

Mechanical dimension (mm)

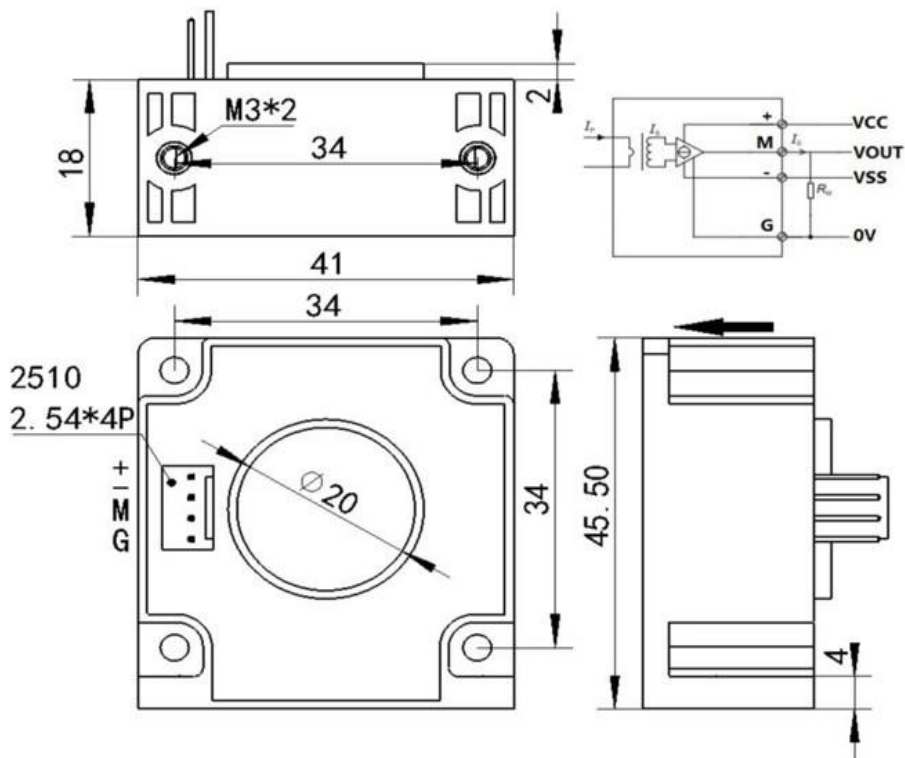

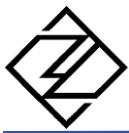

NOTE

- When the direction of the input current I_P is consistent with the direction indicated by the arrow in the outline drawing, the output current I_S is in the forward direction.
- Please try to locate the primary conductor at the center of the probe aperture as much as possible.
- The through-hole is made of metal material, so the through-hole wire cannot be an exposed cable. The through-hole wire must be insulated.
- This module is a standard sensor, please contact us for special applications.
- We reserve the right to modify this sensor manual without prior notice.