



## Current Sensor DXE-DM16

DXE-DM16 is a linear Hall effect sensor used to isolate and measure the magnitude of current in a universal linear Hall sensor device. The output voltage of the linear source is set by the power supply voltage and varies linearly with the current intensity. Adopting CMOS technology, it has the advantages of low voltage and low power consumption, and can operate between 3V and 5.5V. This circuit has the advantages of stable output and good temperature characteristics. It is widely used in commercial, industrial and other fields.



### TYPE

DXE-DM16-100A

DXE-DM16-200A

DXE-DM16-300A

DXE-DM16-400A

DXE-DM16-500A

DXE-DM16-600A

DXE-DM16-700A

DXE-DM16-800A

DXE-DM16-900A

DXE-DM16-1000A



## Features

- Excellent accuracy- Accuracy error<1%
- Very good linearity- Linearity error<0.5%
- Multiple models- 100A,200A,300A,400A,500A,600A,700A,800A,900A,1000A
- Wide frequency bandwidth- > 120kHz
- High compressive strength- > 2KV
- Sensor operating temperature range- -40°C to +125°C

## Application Domain

- Electric Vehicle Battery Management System (BMS)
- Electric Vehicle Battery System Distribution Box (BDU)
- High voltage distribution box (PDU) for electric vehicles
- Energy Management of Industrial Lithium Batteries

## Electrical data (supply voltage=Vcc=5V)

**Limit parameters (note: Do not exceed the maximum value to prevent damage. Prolonged operation at the maximum value may affect the reliability of the device)**

Parameter	Symbol	Specifications	Unit	Condition
Minimum operating voltage	Vcc	4.8	V	
Maximum working voltage	Vcc	6	V	
Output voltage	Vout	5	V	
Storage temperature	Ts	-45-135	°C	
Junction temperature	Tj	165	°C	
ESD	HBM	8000	V	HBM model per Mil-Std-883, Method 3015
ESD	MM	400	V	MM model per JEDEC EIA/JESD22-A115
Latch-up test per JEDEC 78		200	mA	
Dissipation power	Pd	550	mW	
Dielectric Strength	V <sub>D</sub>	2000	V	50Hz, 1min



**Standard parameters (unless otherwise specified: Ta=25 °C, Cp=0.1uF, Vcc=5V)**

Parameter	Symbol	Specifications			Unit	Condition
		Minimum	Standard	Maximum		
Supply Voltage	Vcc	4.8	5	5.2	V	
Working current @Ip=0A	Ic		10	15	mA	
Static output voltage	Vout	2.48	2.5	2.52	V	
Output High Voltage	VOH	4.8	-	-	V	
Output Low Voltage	VOL	-	-	0.2	V	
Output resistance	ROUT	-	-	100	Ω	
Power on response time	TPO	-	0.1	0.2	ms	
Output response time	tRESPONSE	-	3.7	-	us	
Bandwidth	BW	0	-	120	KHz	
Ambient Temperature	TA	-40	-	125	°C	

**Accuracy parameters (unless otherwise specified: Ta=25 °C, Cp=0.1uF, Vcc=5V)**

**Safety characteristics**

Parameter	Symbol	Specifications			Unit	Condition
		Minimum	Standard	Maximum		
Sensitivity	Sense	19.80	20.00	20.20	mV/A	DXE-DM12-100A
		9.90	10.00	10.10	mV/A	DXE-DM12-200A
		6.60	6.67	6.74	mV/A	DXE-DM12-300A
		4.95	5.00	5.05	mV/A	DXE-DM12-400A
		3.96	4.00	4.04	mV/A	DXE-DM12-500A
		3.30	3.33	3.37	mV/A	DXE-DM12-600A
		2.83	2.86	2.89	mV/A	DXE-DM16-700A
		2.48	2.50	2.53	mV/A	DXE-DM16-800A
		2.20	2.22	2.24	mV/A	DXE-DM16-900A
		1.98	2.00	2.02	mV/A	DXE-DM16-1000A
Linearity	Lin	-0.50	-	0.50	%	
Temperature characteristics	VOUT (T)	-1.50	-	1.50	%	
	Sense(T)	2.50	-	2.50	%	
Measuring current	Ip	-100.00	-	100.00	A	DXE-DM12-100A
		-200.00	-	200.00	A	DXE-DM12-200A
		-300.00	-	300.00	A	DXE-DM12-300A
		-400.00	-	400.00	A	DXE-DM12-400A
		-500.00	-	500.00	A	DXE-DM12-500A
		-600.00	-	600.00	A	DXE-DM16-600A
		-700.00	-	700.00	A	DXE-DM16-700A
		-800.00	-	800.00	A	DXE-DM16-800A
		-900.00	-	900.00	A	DXE-DM16-900A
		-1000.00	-	1000.00	A	DXE-DM16-1000A



Measuring range	I <sub>P</sub>	-110.00	-	110.00	A	DXE-DM12-100A
		-220.00	-	220.00	A	DXE-DM12-200A
		-330.00	-	330.00	A	DXE-DM12-300A
		-440.00	-	440.00	A	DXE-DM12-400A
		-550.00	-	550.00	A	DXE-DM12-500A
		-660.00	-	660.00	A	DXE-DM16-600A
		-770.00	-	770.00	A	DXE-DM16-700A
		-880.00	-	880.00	A	DXE-DM16-800A
		-990.00	-	990.00	A	DXE-DM16-900A
		-1100.00	-	1100.00	A	DXE-DM16-1000A
Output noise	V <sub>P-P</sub>	-	20.00	-	mV	C <sub>p</sub> =100nF, C <sub>L</sub> =1.5nF
	V <sub>RMS</sub>	-	2.30	-	mV	C <sub>p</sub> =100nF, C <sub>L</sub> =1.5nF

### Static output voltage temperature curve

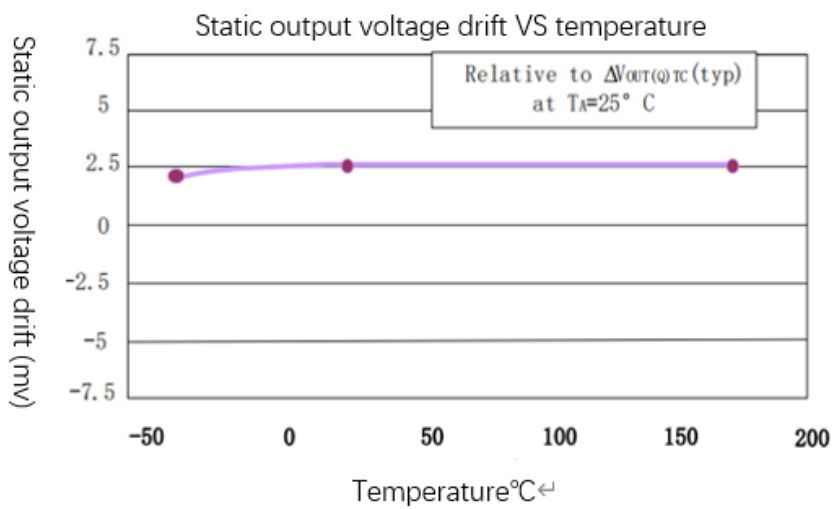

### Sensitivity temperature curve

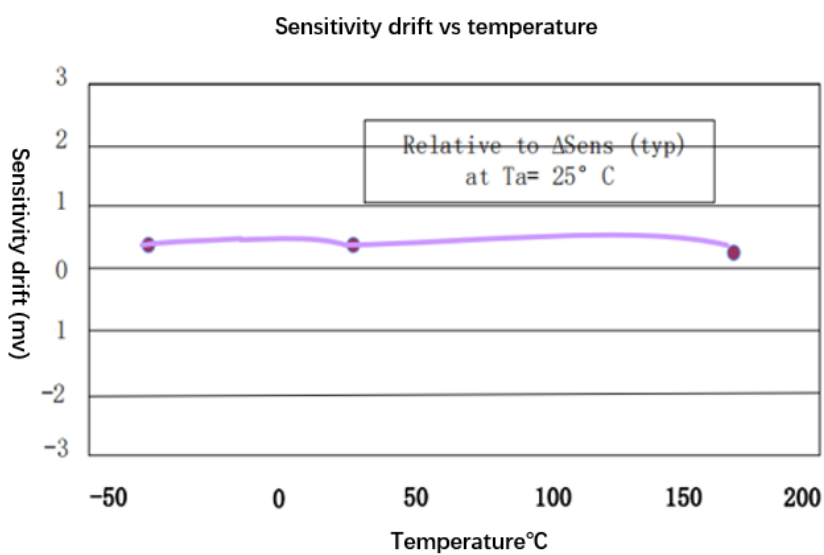



Mechanical dimension (mm)

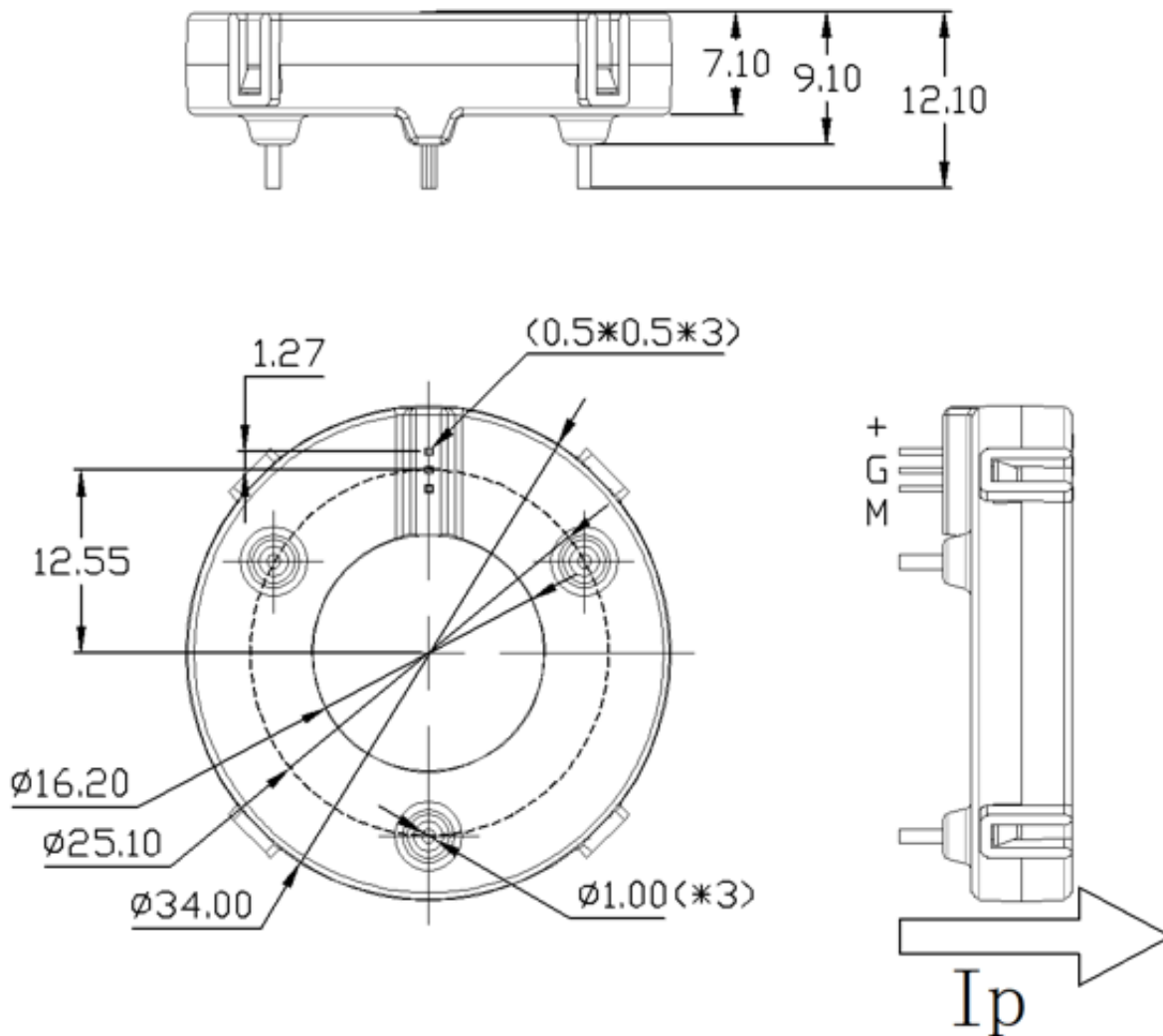

Mechanical characteristics

Characteristic	Rating	Unit
General tolerance	$\pm 0.5$	mm
Other tolerance execution	GB/T 1804-2000-M	
Fixed Pin size	$\phi 1*3$	mm
Pin size	$0.5*0.5*3$	mm
Recommended welding temperature	$265\pm 5$	$^{\circ}\text{C}$
Weight	20	g
Shell material	PA66	
Pin material	tinned brass	

