

Double Packed Stuffing Box

Double packed Stuffing Box (DPSB) is specially designed for pumping unit. It's characteristics as follow:

1. Unique misaligning feature reduces need for exact alignment with the pumping unit
2. Primary packing can be changed under pressure by tightening compression bolts
3. Equipped with the cone packing
4. Lub Upper Gland (LUG) with grease zerk to lubricating the rod
5. Optional Oil Reservoir Gland (ORG) and Anti-Pollution Adapter (APA)
6. LUG has two heavy hex nuts on each bolt, which can support up to 20000 lbs. when engaged during well servicing
7. Flanged bottom connection available by special order
8. Most widely-used stuffing box in the industry

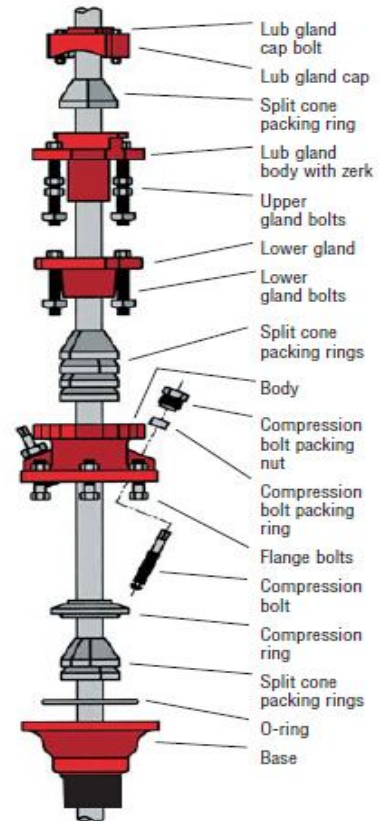

Specification: 1500psi, 2000psi, 3000psi

Connecting Thread: 2-3/8" EUE, 2-7/8" EUE, 3" LP,
3-1/2" EUE

Working Temperature: 149°C (H₂S & CO₂ below 1%)

120°C (H₂S below 2% & CO₂
below 10%)

Good performance at Mechanical Tear and Abrasive Resistance & in Steam Environments

Cone Packing

Cone Packing is available in size for all polished rod 1-1/8", 1-1/4", 1-1/2" in set of four (3 top cone and 1 bottom cone) and five (3 top cone and 2 bottom cone).

